

GROSS LOAD CAPACITY WHEN USED AS A WEIGHT CARRYING HITCH: 3,500 LBS. TRAILER WEIGHT & 350 LBS. TONGUE WEIGHT.
*****DO NOT EXCEED VEHICLE MANUFACTURER'S RECOMMENDED TOWING CAPACITY.*****

| | | | |
|---|---|-----------------|------------------------|
| 1 | 4 | M10 - 1.25 x 30 | HEX BOLT |
| 2 | 4 | 3/8" | CONICAL TOOTHED WASHER |

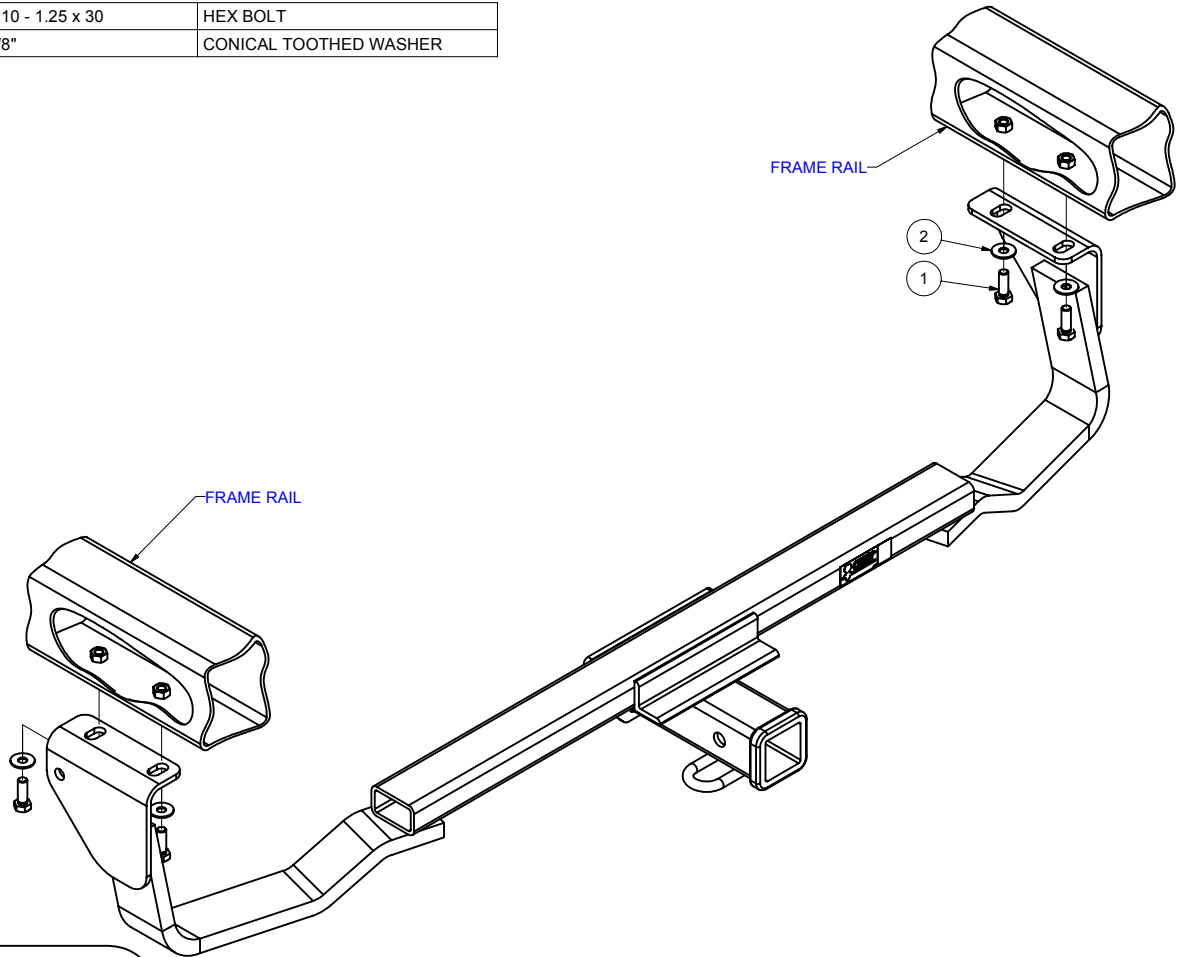

HITCH WEIGHT: 46 LBS.
INSTALL TIME: 60 MINUTES
INSTALL NOTES:
NO DRILL

INSTALLATION STEPS

- 1) Lower exhaust on vehicle.
- 2) Remove tow loop on passenger side of vehicle by first removing heat shield. After tow loop is removed, return heat shield to original position.
- 3) Raise hitch into position and align holes in hitch with holes in frame rails.
- 4) Fasten hitch to vehicle using hardware provided.
- 5) Torque all M10 x 1.25 hardware to 36 lb-ft.
- 6) Return exhaust to original position.

PERIODICALLY CHECK THIS RECEIVER HITCH TO ENSURE THAT ALL FASTENERS ARE TIGHT AND THAT ALL STRUCTURAL COMPONENTS ARE SOUND.