

13550 02-05 FORD EXPLORER, MERCURY MOUNTAINEER & LINCOLN AVIATOR

7/22/2009

GROSS LOAD CAPACITY WHEN USED AS A WEIGHT CARRYING HITCH: 5,000 LBS. TRAILER WEIGHT & 500 LBS. TONGUE WEIGHT.
GROSS LOAD CAPACITY WHEN USED AS A WEIGHT DISTRIBUTION HITCH: 8,000 LBS. TRAILER WEIGHT & 800 LBS. TONGUE WEIGHT

*****DO NOT EXCEED VEHICLE MANUFACTURER'S RECOMMENDED TOWING CAPACITY.*****

Parts List				
ITEM	QTY	PART NUMBER	DESCRIPTION	
1	6	1/2"	WASHER	
2	2	1/2-13 x 1 3/4	CARRIAGE BOLT	
3	2	HFN 1213	HEX FLANGE NUT	
4	6	M12-1.75 x 45mm	HEX TAP BOLT	
5	2	CM-SP1	.250 x 1.50 x 2.00" SQUARE HOLE SPACER	

**WARNING: IF VEHICLE IS
EQUIPPED WITH O.E.M. HITCH
DO NOT USE BOTH
RECEIVERS AT THE SAME TIME.
THIS MAY OVERLOAD AND CAUSE
DAMAGE TO VEHICLE.**

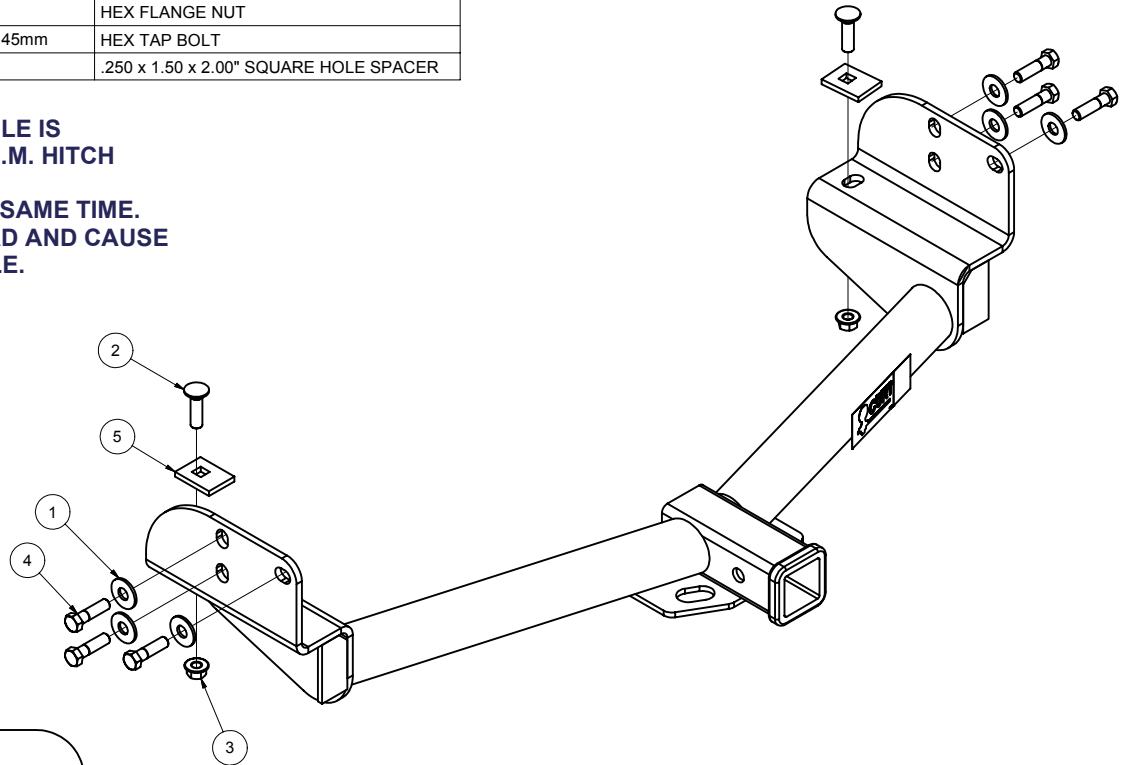

HITCH WEIGHT: 37 LBS.

INSTALL TIME: 30 MINUTES

INSTALL NOTES:

NO DRILLING REQUIRED

INSTALLATION STEPS

- 1) Remove 3 existing bumper bracket nuts (if present) and 3 M12 or M14 bolts from each side of frame.
- 2) Fishwire carriage bolts and square hole spacer through end of frame.
- 3) Raise hitch into position and loosely install washers and nuts.
- 4) - Vehicles with M14 factory fasteners: reinstall factory M14 fasteners.
- Vehicles with M12 factory fasteners: install and torque supplied M12 fasteners and reinstall factory M12 nuts.

Note: Do not use both receivers at the same time. This may cause damage to vehicle.

- 5) Torque all M14 fasteners to 148 ft-lb
Torque all M12 fasteners to 92 ft-lb
Torque all 1/2" fasteners to 75 ft-lb

**PERIODICALLY CHECK THIS RECEIVER HITCH TO ENSURE THAT ALL FASTENERS
ARE TIGHT AND THAT ALL STRUCTURAL COMPONENTS ARE SOUND.**

Curt Manufacturing Inc., warrants this product to be free of defects in material and/or workmanship at the time of retail purchase by the original purchaser. If the product is found to be defective, Curt Manufacturing Inc., may repair or replace the product, at their option, when the product is returned, prepaid, with proof of purchase. Alteration to, misuse of, or improper installation of this product voids the warranty. Curt Manufacturing Inc.'s liability is limited to repair or replacement of products found to be defective, and specifically excludes liability for incidental or consequential loss or damage.