

13551**FORD FLEX**

8/19/2010

EXCLUDES ECO-BOOST MODELS

GROSS LOAD CAPACITY WHEN USED AS A WEIGHT CARRYING HITCH: 5,000 LBS. TRAILER WEIGHT & 500 LBS. TONGUE WEIGHT.
*****DO NOT EXCEED VEHICLE MANUFACTURER'S RECOMMENDED TOWING CAPACITY.*****

Parts List			
ITEM	QTY	PART NUMBER	DESCRIPTION
1	2	1/2-13 x 1 3/4	CARRIAGE BOLT
2	2	CM-SP6	.250 x 1.00 x 3.00" SQUARE HOLE SPACER
3	2	1_2 FISHWIRE	1/2" FISHWIRE
4	2	HFN 1213	HEX FLANGE NUT
5	1	M12-1.75 x 30mm	HEX BOLT
6	1	1/2"	CONICAL TOOTHED WASHER
7	1	CM-SP1	.250 x 1.50 x 2.00" SQUARE HOLE SPACER

TOOLS REQUIRED

DRILL AND 1 1/4" BIT
RATCHET
10" EXTENTION
18mm SOCKET
19mm SOCKET
TORQUE WRENCH

FISHWIRE TECHNIQUE

INSERT COILED END OF FISHWIRE TOOL THROUGH HITCH MOUNTING HOLE IN VEHICLE FRAME RAIL AND OUT THE ACCESS HOLE. PASS COILED END OF FISHWIRE THROUGH SPACER AND THREAD BOLT INTO COIL. KINK WIRE TO KEEP SPACER SEPERATE FROM BOLT AS SHOWN. PULL FISHWIRE, SPACER, AND BOLT THROUGH FRAME AND OUT MOUNTING HOLE. USE FISHWIRE TO GUIDE HITCH DURING MOUNTING AND PREVENT LOSS OF BOLT / SPACER INSIDE FRAME RAIL.

NOTE: SOME VEHICLES MAY FISHWIRE THROUGH END OF FRAME

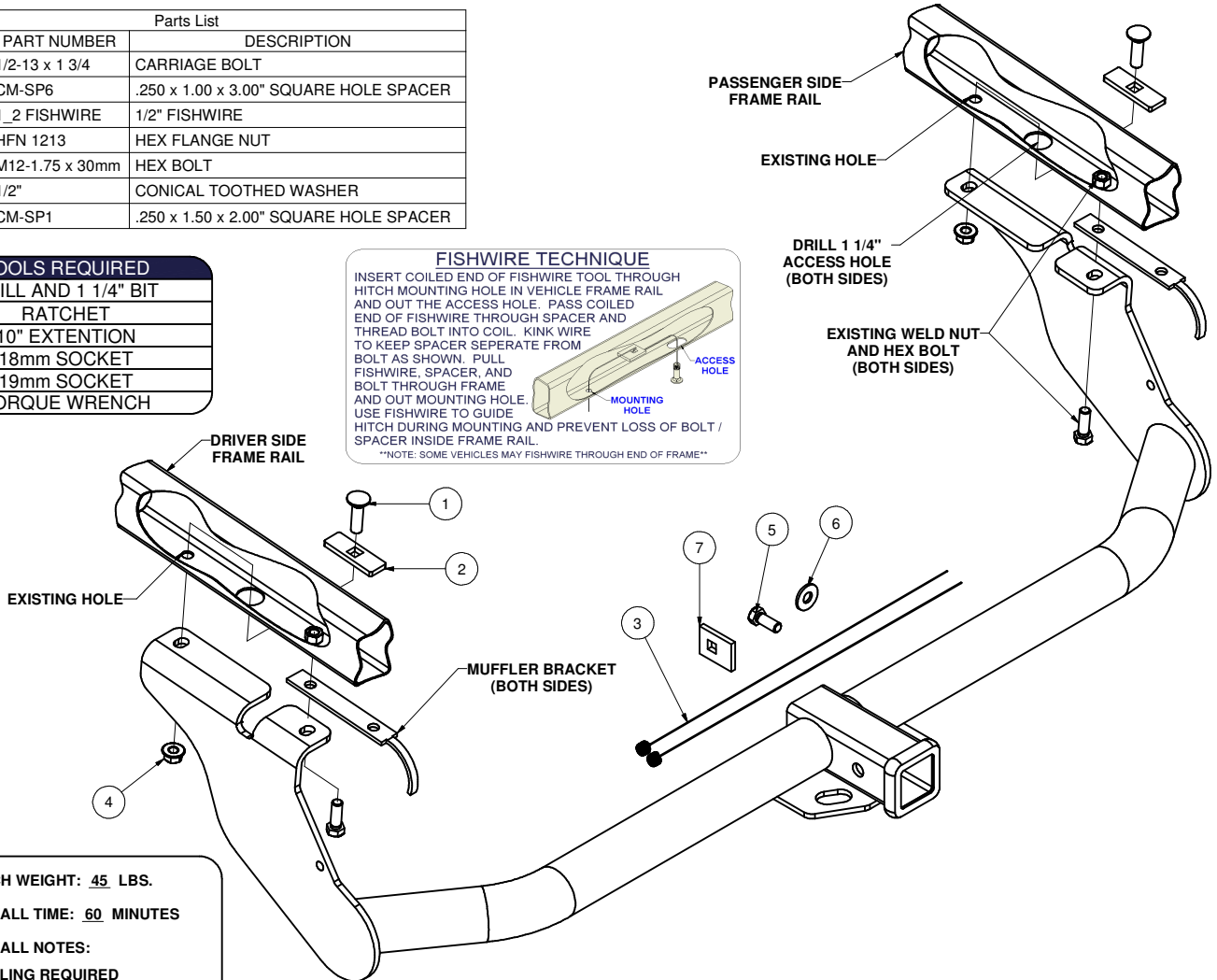
**HITCH WEIGHT: 45 LBS.****INSTALL TIME: 60 MINUTES****INSTALL NOTES:**

- DRILLING REQUIRED
- LOWER MUFFLER BRACKETS
- FISHWIRE HARDWARE

INSTALLATION STEPS

- 1) Remove the M12 bolts on the forward edge of the muffler bracket on each side.
 Note: Do not discard bolts. They will be re-used later.
- 2) Drill an 1-1/4" access hole in frame approximately half way between the M12 weldnut and the existing hole.
- 3) Fishwire the 1/2" carriage bolts and spacers through the access holes and out the existing holes as shown. Leave fishwires attached to bolts.
- 4) Raise the hitch into position against the bottom of vehicle frame and thread the fishwires through the hitch.
 Note: Muffler brackets will be located between the frame and hitch bracket.
- 5) Install supplied 1/2" flange nuts and re-install M12 bolts from step 1. If single exhaust, on the passenger side use items 5, 6, and 7 in place of bracket. Hand tighten all fasteners.
- 6) Torque all 1/2" bolts to 75 lb-ft and all M12 fasteners to 60 lb-ft.

PERIODICALLY CHECK THIS RECEIVER HITCH TO ENSURE THAT ALL FASTENERS ARE TIGHT AND THAT ALL STRUCTURAL COMPONENTS ARE SOUND.

Curt Manufacturing Inc., warrants this product to be free of defects in material and/or workmanship at the time of retail purchase by the original purchaser. If the product is found to be defective, Curt Manufacturing Inc., may repair or replace the product, at their option, when the product is returned, prepaid, with proof of purchase. Alteration to, misuse of, or improper installation of this product voids the warranty. Curt Manufacturing Inc.'s liability is limited to repair or replacement of products found to be defective, and specifically excludes liability for incidental or consequential loss or damage.