

**13558****INFINITI FX45 & FX35**

9/21/2009

GROSS LOAD CAPACITY WHEN USED AS A WEIGHT CARRYING HITCH: 3,500 LBS. TRAILER WEIGHT &amp; 350 LBS. TONGUE WEIGHT.

**\*\*\*DO NOT EXCEED VEHICLE MANUFACTURER'S RECOMMENDED TOWING CAPACITY.\*\*\*****WARNING: ALL NON-TRAILER LOADS APPLIED TO THIS PRODUCT MUST BE SUPPORTED BY AUXILIARY STABILIZING STRAPS.****\*\* FAILURE TO PROPERLY SUPPORT NON-TRAILER LOADS WILL VOID PRODUCT WARRANTY\*\***

HAVING INSTALLATION QUESTIONS? CALL TECHNICAL SUPPORT AT 1-800-798-0813

Parts List				
ITEM	QTY	PART NUMBER	DESCRIPTION	
1	1	CM-438-FW	7/16" FISHWIRE TOOL	
2	2	M12-1.25 x 30mm	HEX BOLT	
3	2	1/2"	CONICAL TOOTHED WASHER	
4	4	CM-SP7	.250 x 1.00 x 2.00" SQUARE HOLE SPACER	
5	4	7/16-14	LARGE HEX FLANGE NUT	
6	4	7/16-14 x 1 1/4	CARRIAGE BOLT	

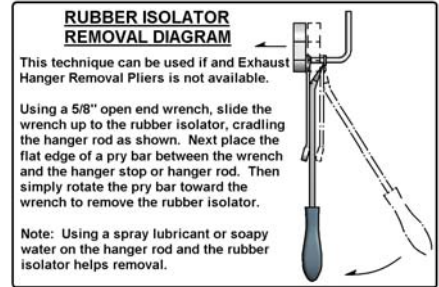
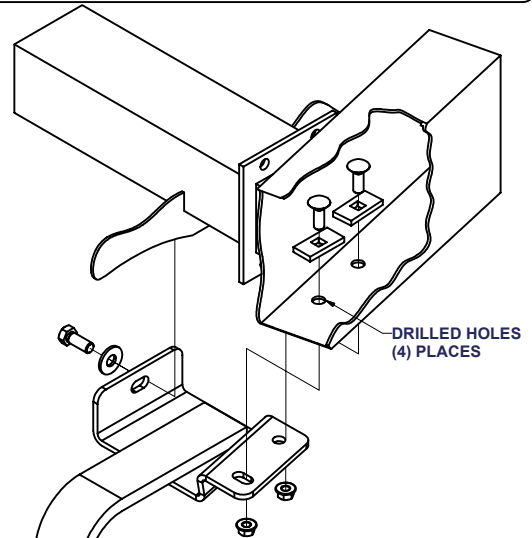
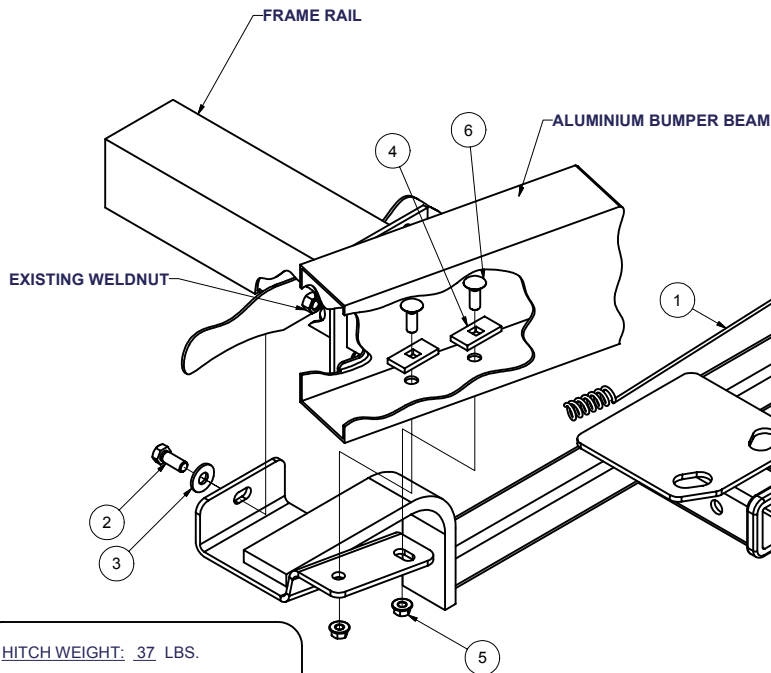

HITCH WEIGHT: 37 LBS.

**INSTALL TIME**

PROFESSIONAL: 45 MINUTES

NOVICE (DIY): 90 MINUTES

**INSTALL NOTES:**

- DRILLING REQUIRED
- LOWER EXHAUST
- TEMPORARILY REMOVE GRAVEL SHIELD

**INSTALLATION STEPS**

1. Remove left and right gravel shields by removing plastic push pins. **(Note: These will be reinstalled at end of installation.)** Lower exhaust hangers left, right and center.
2. Attach hitch to forward side of existing vertical weld nut plate using M12 bolts, each side.
3. Pull fascia rearward and drill four places in aluminum bumper beam using hitch as template.
4. Fishwire the 7/16" carriage bolts and spacers through open end of bumper into previously drilled holes and fasten with flange nuts.
5. Torque 7/16" fasteners to 50 lb.-ft. Torque M12 fasteners to 65 lb.-ft. Reattach exhaust and gravel shields.

**PERIODICALLY CHECK THIS RECEIVER HITCH TO ENSURE THAT ALL FASTENERS ARE TIGHT AND THAT ALL STRUCTURAL COMPONENTS ARE SOUND.**

**FRONT**  
↑  
**REAR**

Curt Manufacturing Inc., warrants this product to be free of defects in material and/or workmanship at the time of retail purchase by the original purchaser. If the product is found to be defective, Curt Manufacturing Inc., may repair or replace the product, at their option, when the product is returned, prepaid, with proof of purchase. Alteration to, misuse of, or improper installation of this product voids the warranty. Curt Manufacturing Inc.'s liability is limited to repair or replacement of products found to be defective, and specifically excludes liability for incidental or consequential loss or damage.