

13559

VOLVO XC90

9/21/2009

GROSS LOAD CAPACITY WHEN USED AS A WEIGHT CARRYING HITCH: 3,500 LBS. TRAILER WEIGHT & 350 LBS. TONGUE WEIGHT.  
 GROSS LOAD CAPACITY WHEN USED AS A WEIGHT DISTRIBUTION HITCH: 5,000 LBS. TRAILER WEIGHT & 500 LBS. TONGUE WEIGHT

\*\*\*DO NOT EXCEED VEHICLE MANUFACTURER'S RECOMMENDED TOWING CAPACITY.\*\*\*

HAVING INSTALLATION QUESTIONS? CALL TECHNICAL SUPPORT AT 1-800-798-0813

Parts List			
ITEM	QTY	PART NUMBER	DESCRIPTION
1	2	1/2"	CONICAL TOOTHED WASHER
2	2	M12-1.75 x 40mm	HEX BOLT

#### RUBBER ISOLATOR REMOVAL DIAGRAM

This technique can be used if and Exhaust Hanger Removal Pliers is not available.

Using a 5/8" open end wrench, slide the wrench up to the rubber isolator, cradling the hanger rod as shown. Next place the flat edge of a pry bar between the wrench and the hanger stop or hanger rod. Then simply rotate the pry bar toward the wrench to remove the rubber isolator.

Note: Using a spray lubricant or soapy water on the hanger rod and the rubber isolator helps removal.



PASSENGER SIDE FRAME RAIL

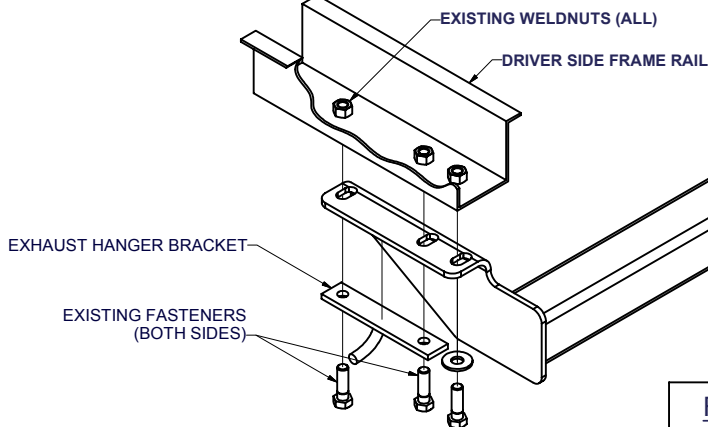

#### FASCIA TRIM DIAGRAM FOR RECIEVER TUBE

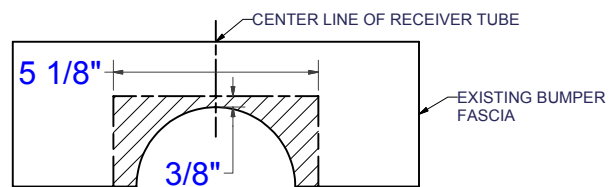

HITCH WEIGHT: 30 LBS.

#### INSTALL TIME

PROFESSIONAL: 30 MINUTES

NOVICE (DIY): 60 MINUTES

#### INSTALL NOTES:

- NO DRILLING REQUIRED
- FASCIA TRIMMING REQUIRED
- LOWER SPARE TIRE

FRONT  
↓  
REAR

## INSTALLATION STEPS

1. Temporarily remove the existing M12 fasteners securing the tie down bracket to the passenger side frame rail and the rearmost exhaust hanger bracket from the driver's side frame rail. Retain the fasteners for later use.
2. Lower the spare tire to ease installation.
3. Loosely position the hitch under the car aligning the slots in the hitch with the three 12mm weld nuts in each frame rail.
4. Trim the fascia as shown to fit the hitch under the vehicle. (See above diagram.)
5. Replace the exhaust hanger bracket under the driver side plate of the hitch.
6. Mount the hitch using the 12mm bolts removed in Step 1 and the provided 12mm bolts and conical tooth washers as shown.
7. Torque all M12 fasteners to 59 lb.-ft.

**PERIODICALLY CHECK THIS RECEIVER HITCH TO ENSURE THAT ALL FASTENERS ARE TIGHT AND THAT ALL STRUCTURAL COMPONENTS ARE SOUND.**

Curt Manufacturing Inc., warrants this product to be free of defects in material and/or workmanship at the time of retail purchase by the original purchaser. If the product is found to be defective, Curt Manufacturing Inc., may repair or replace the product, at their option, when the product is returned, prepaid, with proof of purchase. Alteration to, misuse of, or improper installation of this product voids the warranty. Curt Manufacturing Inc.'s liability is limited to repair or replacement of products found to be defective, and specifically excludes liability for incidental or consequential loss or damage.

78590 / 757590