

13572 99-02 MERCURY VILLAGER / 99-02 NISSAN QUEST

10/20/09

GROSS LOAD CAPACITY WHEN USED AS A WEIGHT CARRYING HITCH: 3,500 LBS. TRAILER WEIGHT & 350 LBS. TONGUE WEIGHT.
GROSS LOAD CAPACITY WHEN USED AS A WEIGHT DISTRIBUTION HITCH: 5,000 LBS. TRAILER WEIGHT & 500 LBS. TONGUE WEIGHT
*****DO NOT EXCEED VEHICLE MANUFACTURER'S RECOMMENDED TOWING CAPACITY.*****

| Parts List | | | |
|------------|-----|-----------------|-------------|
| ITEM | QTY | PART NUMBER | DESCRIPTION |
| 1 | 6 | 1/2" | LOCK WASHER |
| 2 | 6 | M12-1.25 x 30mm | HEX BOLT |

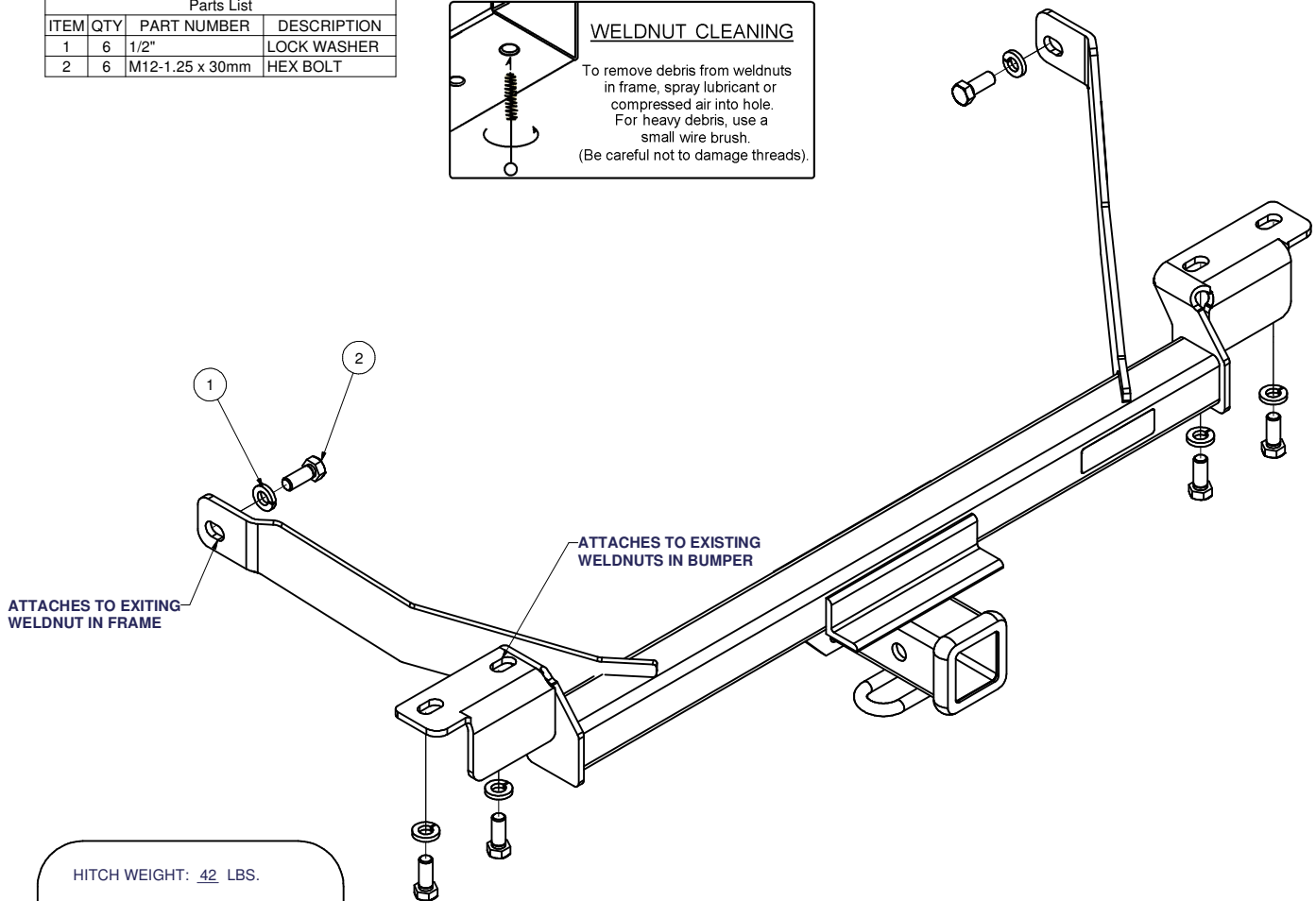
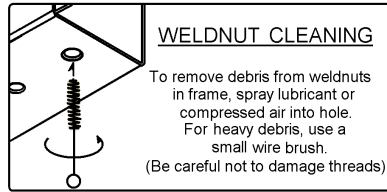

HITCH WEIGHT: 42 LBS.
INSTALL TIME: 30 MINUTES
INSTALL NOTES:

INSTALLATION STEPS

- 1) Raise vehicle for access to underside.
- 2) Unfasten (2) most rearward exhaust hangers.
- 3) Raise hitch into position by lifting right mounting plate up & over the tailpipe, and under the exhaust hanger bracket.
- 4) Line up the hole in the side plates with the inboard holes of the vehicle frame. The holes in the mounting plates should then line up with the forwardmost lower holes on the inboard sides of the vehicle frame rails.
- 5) Secure hitch by inserting 12mm bolts and washers.
- 6) Torque all 12mm fasteners to 68 LB.-FT.

PERIODICALLY CHECK THIS RECEIVER HITCH TO ENSURE THAT ALL FASTENERS ARE TIGHT AND THAT ALL STRUCTURAL COMPONENTS ARE SOUND.

Curt Manufacturing Inc., warrants this product to be free of defects in material and/or workmanship at the time of retail purchase by the original purchaser. If the product is found to be defective, Curt Manufacturing Inc., may repair or replace the product, at their option, when the product is returned, prepaid, with proof of purchase. Alteration to, misuse of, or improper installation of this product voids the warranty. Curt Manufacturing Inc.'s liability is limited to repair or replacement of products found to be defective, and specifically excludes liability for incidental or consequential loss or damage.

12/22/05