

13573

BMW X3

8/12/2010

GROSS LOAD CAPACITY WHEN USED AS A WEIGHT CARRYING HITCH: 3,500 LBS. TRAILER WEIGHT & 350 LBS. TONGUE WEIGHT.
GROSS LOAD CAPACITY WHEN USED AS A WEIGHT DISTRIBUTION HITCH: 4,000 LBS. TRAILER WEIGHT & 400 LBS. TONGUE WEIGHT

DO NOT EXCEED VEHICLE MANUFACTURER'S RECOMMENDED TOWING CAPACITY.

HAVING INSTALLATION QUESTIONS? CALL TECHNICAL SUPPORT AT 1-800-798-0813

Parts List			
ITEM	QTY	PART NUMBER	DESCRIPTION
1	4	M12-1.75	HEX FLANGE NUT

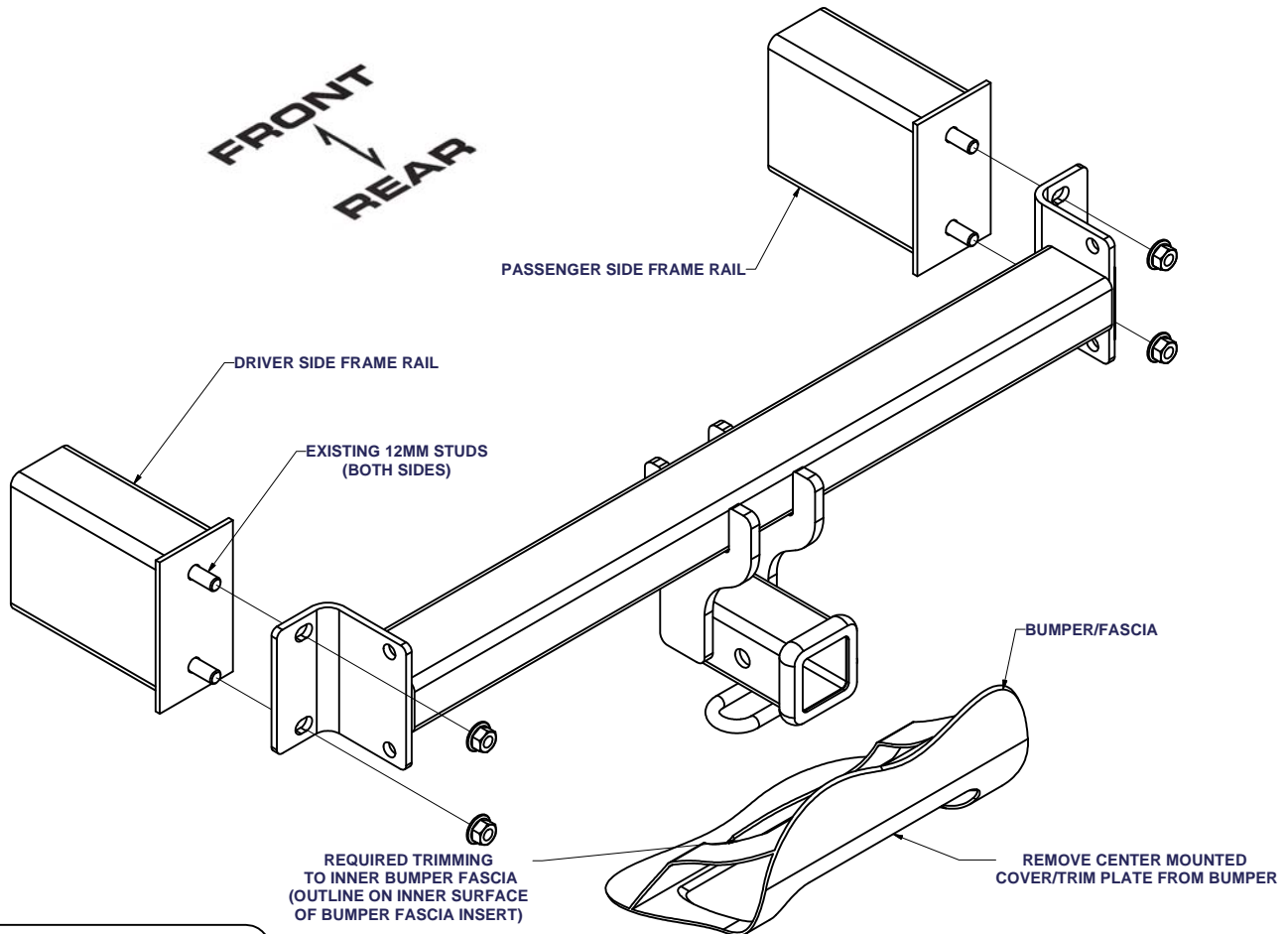
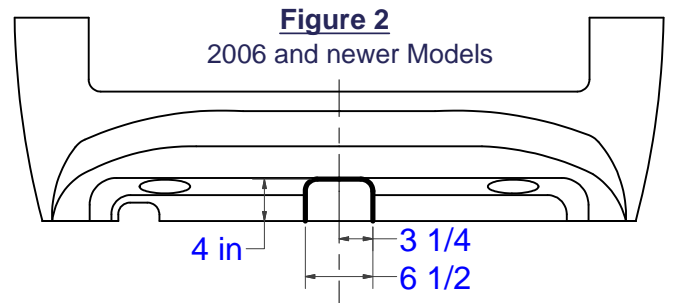
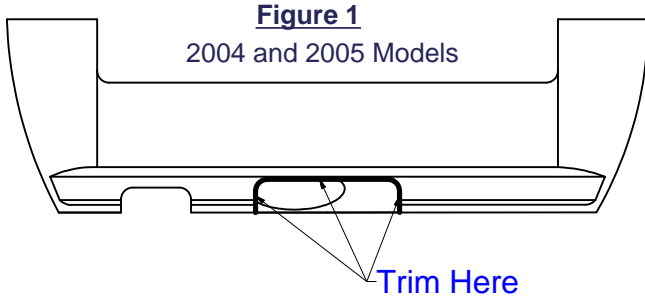

HITCH WEIGHT: 31 LBS.

INSTALL TIME

PROFESSIONAL: 3-4 HOURS

NOVICE (DIY): 6-8 HOURS

INSTALL NOTES:

- REMOVE BUMPER FASCIA
- TRIM BUMPER FASCIA
- DISCARD STEEL BUMPER
- REINSTALL BUMPER FASCIA

On newer models more extensive inner fascia trimming required for proper fit

PERIODICALLY CHECK THIS RECEIVER HITCH TO ENSURE THAT ALL FASTENERS ARE TIGHT AND THAT ALL STRUCTURAL COMPONENTS ARE SOUND.

Curt Manufacturing Inc., warrants this product to be free of defects in material and/or workmanship at the time of retail purchase by the original purchaser. If the product is found to be defective, Curt Manufacturing Inc., may repair or replace the product, at their option, when the product is returned, prepaid, with proof of purchase. Alteration to, misuse of, or improper installation of this product voids the warranty. Curt Manufacturing Inc.'s liability is limited to repair or replacement of products found to be defective, and specifically excludes liability for incidental or consequential loss or damage.



MARK OUT THE INNER BUMPER BEAM AS SHOWN TO THE LEFT.



USING A ROTARY OR EQUIVALENT CUTTING TOOL, TRIM BUMPER FASCIA AS SHOWN TO THE RIGHT.

INSTALLATION STEPS

1. **Remove rear fascia as noted below.**
 - A. On 2004 & 2005 models, remove access door from bottom of fascia and return to vehicle owner.
 - B. Remove (3) nuts/screws in each tire well.
 - C. Carefully pull the wheel well liners out and over the lip of the bumper fascia.
 - D. While pulling the wheel well liner out of the way, remove the screw holding the bumper fascia on the driver and passenger side of the vehicle.
 - E. Next, remove the bottom (2) screws in each of the tire wells.
 - F. Remove (1) screw on the bottom of the fascia near the muffler.
 - G. Remove (1) plastic nut in the corner near the muffler.
 - H. Remove (1) plastic nut under the passenger side.
 - I. Open the trunk and pull the lip of the fascia up away from the bumper cover.
 - J. Remove the fascia lip from the vehicle.
 - K. Remove (4) screws on the top of the bumper.
 - L. Pull the bumper cover and white inner bumper away from the vehicle.
2. Trim the fascia.
 - A. 2004 & 2005 Models: trim inner fascia as shown in **Figure 1**. Trim the inner fascia to same profile as the access door. Trimming the outer fascia is not required.
 - B. 2006 Models: trim outer and inner fascia as shown in **Figure 2**. Measure from fascia clearance as shown.
 - C. On newer models more extensive inner fascia trimming is required for proper fit as shown on page 2.
3. Remove and discard steel bumper by removing (2) nuts each side, which secure the bumper to the rear vehicle frame.
4. Raise hitch into position, in place of steel bumper and secure with M12 flange nuts
5. Torque all 12mm fasteners to 60 lb-ft.
6. Reinstall fascia.

PERIODICALLY CHECK THIS RECEIVER HITCH TO ENSURE THAT ALL FASTENERS ARE TIGHT AND THAT ALL STRUCTURAL COMPONENTS ARE SOUND.