

**13657****86-96 JEEP WRANGLER (EXCEPT RENEGADE)**

6/4/2009

GROSS LOAD CAPACITY WHEN USED AS A WEIGHT CARRYING HITCH: 3,500 LBS. TRAILER WEIGHT &amp; 350 LBS. TONGUE WEIGHT.

**\*\*\*DO NOT EXCEED VEHICLE MANUFACTURER'S RECOMMENDED TOWING CAPACITY.\*\*\***

Parts List			
ITEM	QTY	PART NUMBER	DESCRIPTION
1	8	3/8-16	HEX FLANGE NUT
2	8	3/8-16 x 1 1/2	HEX TAP BOLT
3	8	3/8"	WASHER
4	2	7/16-14 x 1 1/4	HEX TAP BOLT
5	2	7/16"	CONICAL TOOTHED WASHER

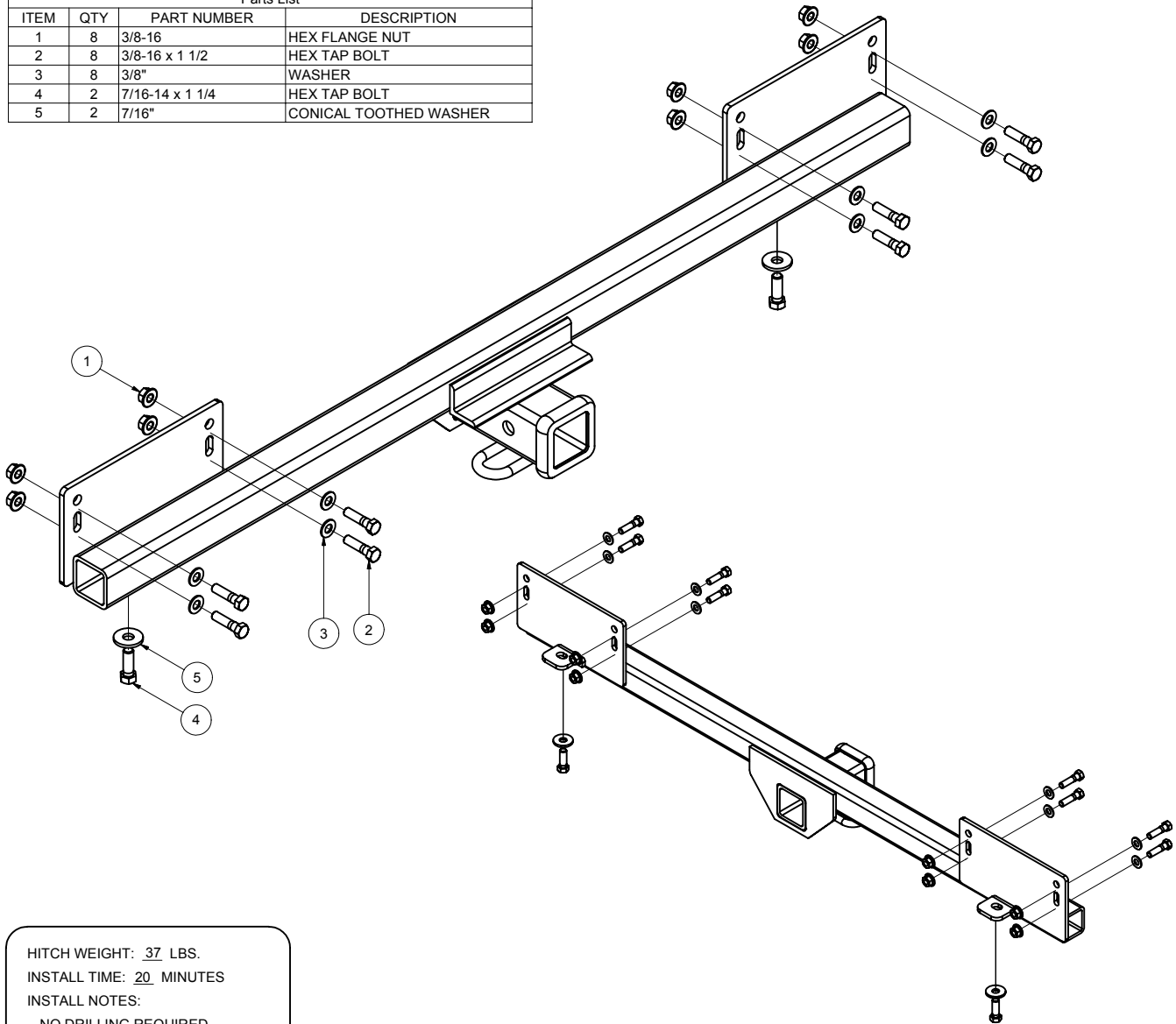

HITCH WEIGHT: 37 LBS.  
 INSTALL TIME: 20 MINUTES  
 INSTALL NOTES:  
 - NO DRILLING REQUIRED

**INSTALLATION STEPS**

- 1) LOCATE EXISTING HOLES IN FRAME. RAISE THE HITCH INTO POSITION AND INSTALL FASTENERS AS SHOWN.
- 2) CHECK AND TIGHTEN ALL FASTENERS AS SPECIFIED BELOW:
  - TORQUE ALL 3/8" HARDWARE TO 31 FT-LBS.
  - TORQUE ALL 7/16" HARDWARE TO 50 FT-LBS.

**PERIODICALLY CHECK THIS RECEIVER HITCH TO ENSURE THAT ALL FASTENERS ARE TIGHT AND THAT ALL STRUCTURAL COMPONENTS ARE SOUND.**

Curt Manufacturing Inc., warrants this product to be free of defects in material and/or workmanship at the time of retail purchase by the original purchaser. If the product is found to be defective, Curt Manufacturing Inc., may repair or replace the product, at their option, when the product is returned, prepaid, with proof of purchase. Alteration to, misuse of, or improper installation of this product voids the warranty. Curt Manufacturing Inc.'s liability is limited to repair or replacement of products found to be defective, and specifically excludes liability for incidental or consequential loss or damage.