

**13800****01-06 MITSUBISHI MONTERO (EXCEPT SPORT)****5/28/2009**

GROSS LOAD CAPACITY WHEN USED AS A WEIGHT CARRYING HITCH: 5,000 LBS. TRAILER WEIGHT & 500 LBS. TONGUE WEIGHT.  
 GROSS LOAD CAPACITY WHEN USED AS A WEIGHT DISTRIBUTION HITCH: 6,000 LBS. TRAILER WEIGHT & 600 LBS. TONGUE WEIGHT  
**\*\*\*DO NOT EXCEED VEHICLE MANUFACTURER'S RECOMMENDED TOWING CAPACITY.\*\*\***

| Parts List |     |                     |                        |
|------------|-----|---------------------|------------------------|
| ITEM       | QTY | PART NUMBER         | DESCRIPTION            |
| 1          | 2   | CM-HCT-15           | 7" CABLE TIE           |
| 2          | 5   | M12 - 1.25 x 40 HEX | HEX TAP BOLT           |
| 3          | 5   | 1/2"                | CONICAL TOOTHED WASHER |

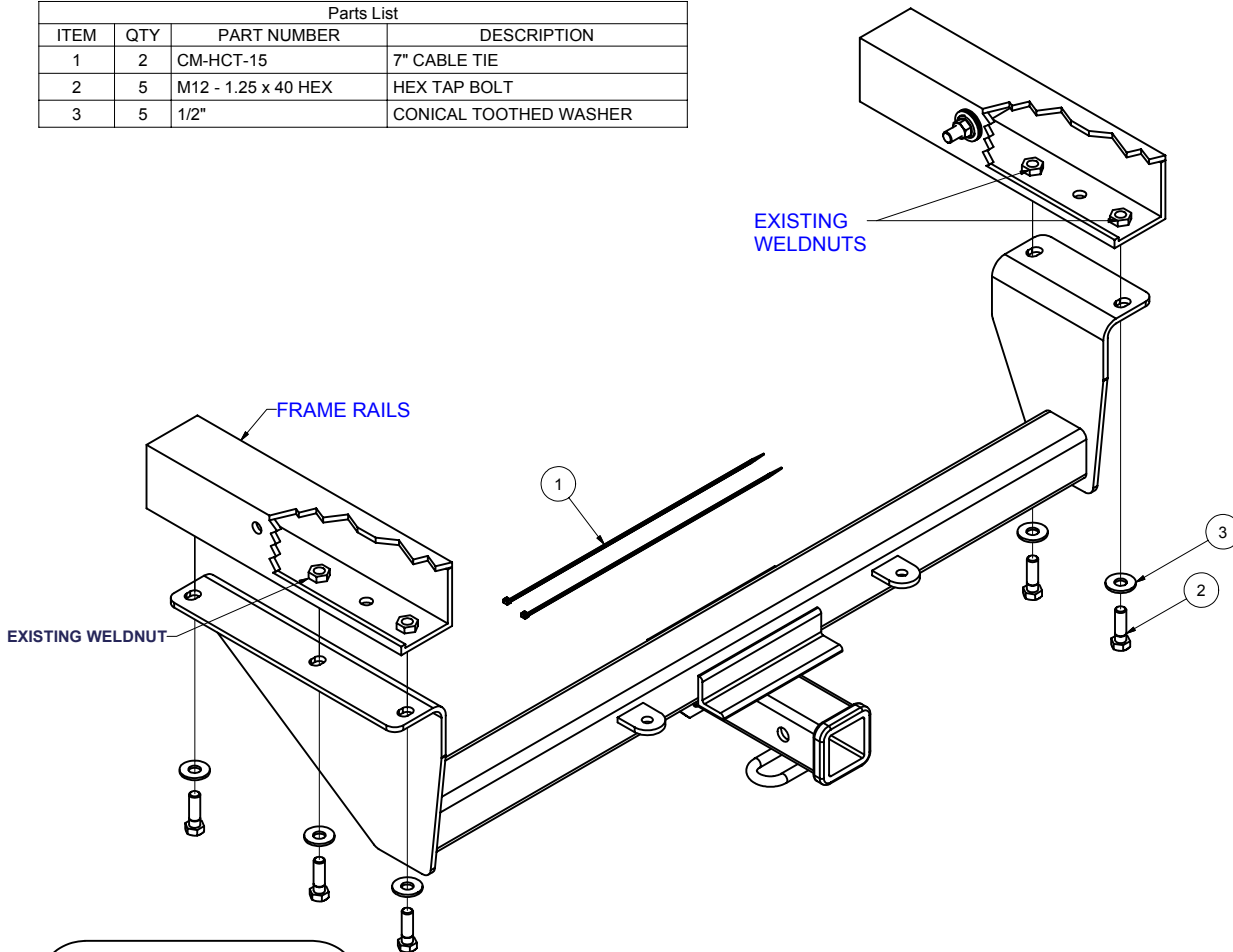

HITCH WEIGHT: 40 LBS.  
 INSTALL TIME: 30 MINUTES  
 INSTALL NOTES:  
**NO DRILLING REQUIRED**

**INSTALLATION STEPS**

- 1) Remove the plastic fascia by removing the bottom fasteners from the tow hook assembly bracket.
- 2) Remove the entire tow hook assembly, eight fasteners total.
- 3) Install a M12 bolt in the forward passenger side hole if the vehicle is equipped with a rear air conditioning unit, this will prevent any future noise created from vibration.
- 4) Raise the hitch into position and loosely install the M12 fasteners as shown.
- 5) Reattach the plastic fascia with cable ties provided.
- 6) Torque all fasteners to 68 lb.-ft.

**PERIODICALLY CHECK THIS RECEIVER HITCH TO ENSURE THAT ALL FASTENERS ARE TIGHT AND THAT ALL STRUCTURAL COMPONENTS ARE SOUND.**

Curt Manufacturing Inc., warrants this product to be free of defects in material and/or workmanship at the time of retail purchase by the original purchaser. If the product is found to be defective, Curt Manufacturing Inc., may repair or replace the product, at their option, when the product is returned, prepaid, with proof of purchase. Alteration to, misuse of, or improper installation of this product voids the warranty. Curt Manufacturing Inc.'s liability is limited to repair or replacement of products found to be defective, and specifically excludes liability for incidental or consequential loss or damage.

11/3/2006