

**14250****03-06 DODGE / FREIGHTLINER SPRINTER**

1/13/2011

**WILL NOT FIT 140" DUAL WHEEL SPRINTER MODEL**

**GROSS LOAD CAPACITY WHEN USED AS A WEIGHT CARRYING HITCH: 10000 LBS. TRAILER WEIGHT & 1000 LBS. TONGUE WEIGHT.**  
**GROSS LOAD CAPACITY WHEN USED AS A WEIGHT DISTRIBUTION HITCH: 12000 LBS. TRAILER WEIGHT & 1200 LBS. TONGUE WEIGHT**

\*\*\*DO NOT EXCEED VEHICLE MANUFACTURER'S RECOMMENDED TOWING CAPACITY.\*\*\*

Parts List			
ITEM	QTY	PART NUMBER	DESCRIPTION
1	1	1/2"	FISHWIRE TOOL
2	2	CM-SP10	.250 x 1.00 x 2.50" SQUARE HOLE SPACER
4	8	HFN 1213	HEX FLANGE NUT
5	6	1_2 - 13 x 4	HEX BOLT
6	6	1/2"	WASHER
7	2	CM-SP143	PLATE .250" A-36 H.R.
8	2	1/2-13 x 1 1/2	CARRIAGE BOLT

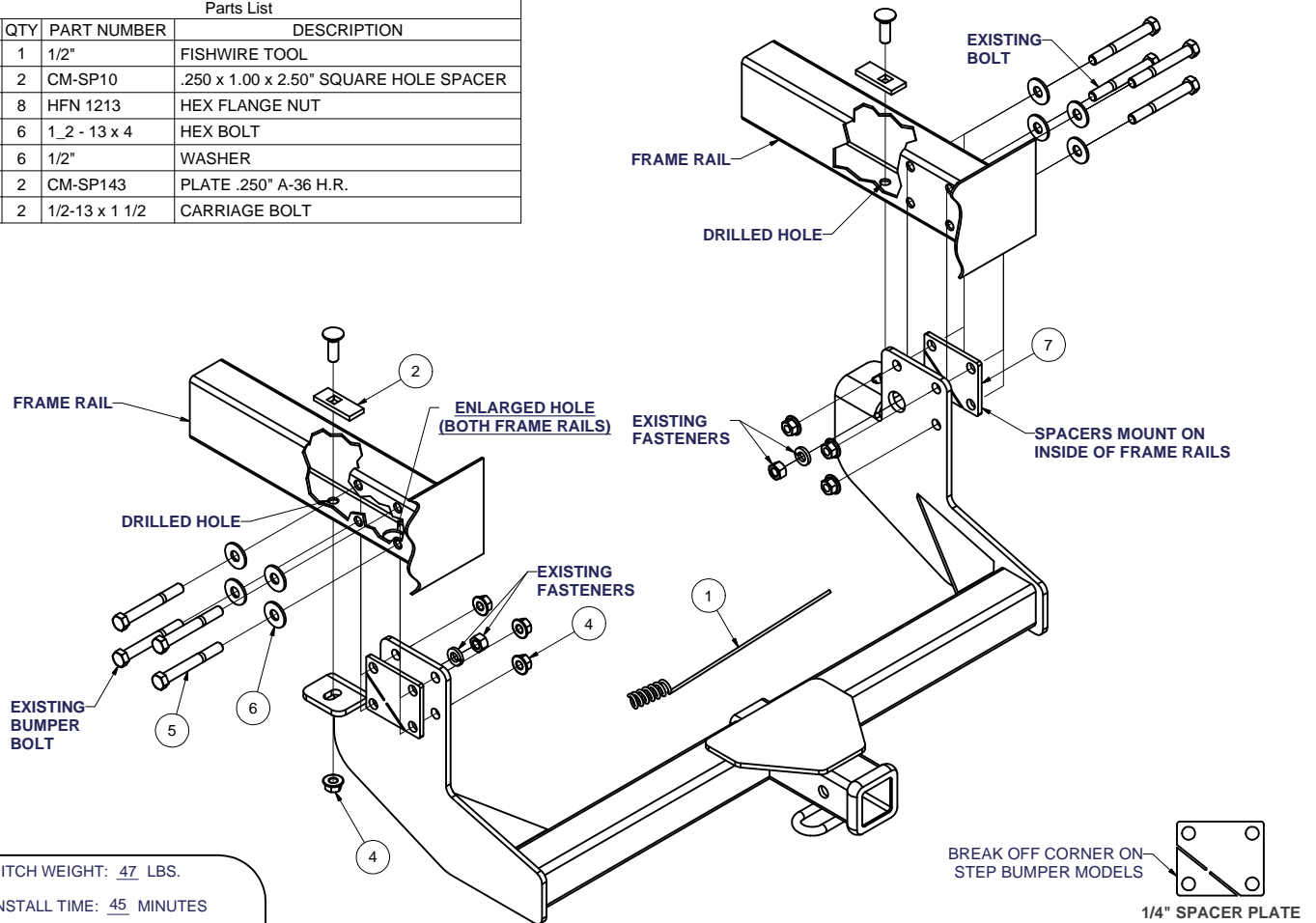

HITCH WEIGHT: 47 LBS.

INSTALL TIME: 45 MINUTES

INSTALL NOTES:

-DRILLING REQUIRED  
 -BUMPER BRACKET  
 MODIFICATION REQUIRED

**-WILL NOT FIT 140" DUAL WHEEL SPRINTER MODEL****-118" WHEEL BASE VEHICLES NEED TO HAVE SPARE RELOCATED AND EXHAUST HANGER MODIFIED.****-158" WHEEL BASE VEHICLES WITH DUAL WHEELS NEED TO HAVE STEP BUMPER SUPPORT BRACE REMOVED FROM THE PASSENGER SIDE STEP BUMPER BRACKET.****INSTALLATION STEPS**

- 1) Remove (2) existing bumper bolts from each side of the frame.(For step bumper models only.)
- 2) Remove undercoating from mounting surfaces as needed.
- 3) For step bumper models, break off corner of 1/4" spacer plates as shown. Position spacer plates on the inside of frame rails. Raise hitch into position, using existing frame holes, install the 1/2" x 4" hex bolts, flatwashers, and flange nuts. (Note: Do not break off spacer corner for non-step bumper models.)
- 4) Reinstall the bumper bracket fasteners removed in step 1.
- 5) Using hitch as a template, drill (2) 9/16" holes through frame as shown. Enlarge existing holes in bottom of frame rails to 1 1/8".
- 6) Fishwire 1/2" carriage bolts and spacers through enlarged holes and secure with flange nuts.
- 7) Torque all 1/2" fasteners to 75 lb-ft and all M12 fasteners to 73 lb-ft (bumper bracket fasteners).

PERIODICALLY CHECK THIS RECEIVER HITCH TO ENSURE THAT ALL FASTENERS  
 ARE TIGHT AND THAT ALL STRUCTURAL COMPONENTS ARE SOUND.

Curt Manufacturing Inc., warrants this product to be free of defects in material and/or workmanship at the time of retail purchase by the original purchaser. If the product is found to be defective, Curt Manufacturing Inc., may repair or replace the product, at their option, when the product is returned, prepaid, with proof of purchase. Alteration to, misuse of, or improper installation of this product voids the warranty. Curt Manufacturing Inc.'s liability is limited to repair or replacement of products found to be defective, and specifically excludes liability for incidental or consequential loss or damage.