

14332**99-07 CHEVY/GMC 1500/2500LD SILVERADO, SIERRA, Z71**

11/3/2006

**GROSS LOAD CAPACITY WHEN USED AS A WEIGHT CARRYING HITCH: 10,000 LBS. TRAILER WEIGHT & 1,200 LBS. TONGUE WEIGHT.
GROSS LOAD CAPACITY WHEN USED AS A WEIGHT DISTRIBUTION HITCH: 12,000 LBS. TRAILER WEIGHT & 1,000 LBS. TONGUE WEIGHT**

*****DO NOT EXCEED VEHICLE MANUFACTURER'S RECOMMENDED TOWING CAPACITY.*****

Parts List			
ITEM	QTY	PART NUMBER	DESCRIPTION
1	4	1/2-13 x 1 3/4	CARRIAGE BOLT
2	4	CM-SP1	.250 x 1.50 x 2.00" SQUARE HOLE SPACER
3	4	1/2 - 13	HEX FLANGE NUT
4	2	9/16	LOCK WASHER
5	4	M14-2 x 40mm LG.	HEX TAP BOLT
6	2	1/2"	CONICAL TOOTHED WASHER

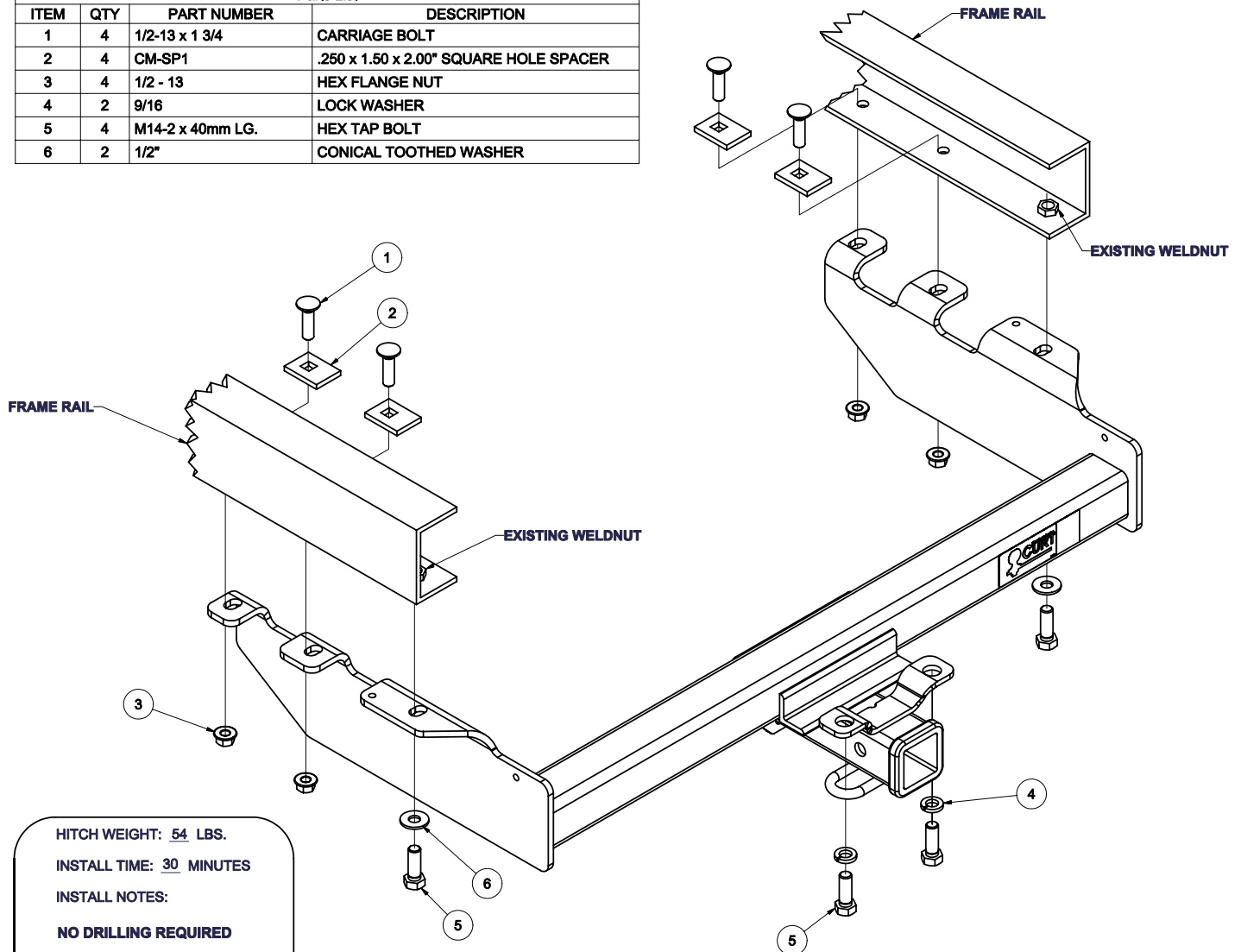

HITCH WEIGHT: 54 LBS.

INSTALL TIME: 30 MINUTES

INSTALL NOTES:

NO DRILLING REQUIRED

INSTALLATION STEPS

- 1) Lower spare tire and remove existing M14 hex bolts from each frame rail as shown. (Reuse later)
- 2) Raise hitch into position and secure bumper mount with M14 hex bolts and lock washers as shown. (Leave bolts loose.)
- 3) Reinstall existing M14 hardware in rear holes of hitch and install 1/2" carriage bolts, spacers, and flange nuts in remaining holes as shown.
- 4) Torque rear M14 bolt first to 100 lb.-ft and all 1/2" fasteners to 75 lb.-ft.
- 5) Reinstall spare tire removed in step (1).

PERIODICALLY CHECK THIS RECEIVER HITCH TO ENSURE THAT ALL FASTENERS ARE TIGHT AND THAT ALL STRUCTURAL COMPONENTS ARE SOUND.

Curt Manufacturing Inc., warrants this product to be free of defects in material and/or workmanship at the time of retail purchase by the original purchaser. If the product is found to be defective, Curt Manufacturing Inc., may repair or replace the product, at their option, when the product is returned, prepaid, with proof of purchase. Alteration to, misuse of, or improper installation of this product voids the warranty. Curt Manufacturing Inc.'s liability is limited to repair or replacement of products found to be defective, and specifically excludes liability for incidental or consequential loss or damage.

2/24/06