

10/25/2006

14361

DODGE RAM PICK-UP

GROSS LOAD CAPACITY WHEN USED AS A WEIGHT CARRYING HITCH: 10,000 LBS. TRAILER WEIGHT & 1,000 LBS. TONGUE WEIGHT.
GROSS LOAD CAPACITY WHEN USED AS A WEIGHT DISTRIBUTION HITCH: 12,000 LBS. TRAILER WEIGHT & 1,200 LBS. TONGUE WEIGHT
*****DO NOT EXCEED VEHICLE MANUFACTURER'S RECOMMENDED TOWING CAPACITY.*****

Parts List			
ITEM	QTY	PART NUMBER	DESCRIPTION
1	4	1/2 - 13 x 2"	CARRIAGE BOLT
2	2	CM-SP4	.250 x 1.50 x 3.00" SQUARE HOLE SPACER
3	2	CM-SP48	.250 x 2.13 x 2.13" SQUARE HOLE SPACER
4	2	1/2-13 x 2 1/4	HEX BOLT
5	2	1/2"	WASHER
6	4	CM-SP34	.188 x 1.50 x 3.00" ROUND HOLE SPACER
7	1	1/2"	FISHWIRE TOOL
8	2	CM-SP32	.188 x 1.50 x 2.00" ROUND HOLE SPACER
9	6	HFN 1213	HEX FLANGE NUT

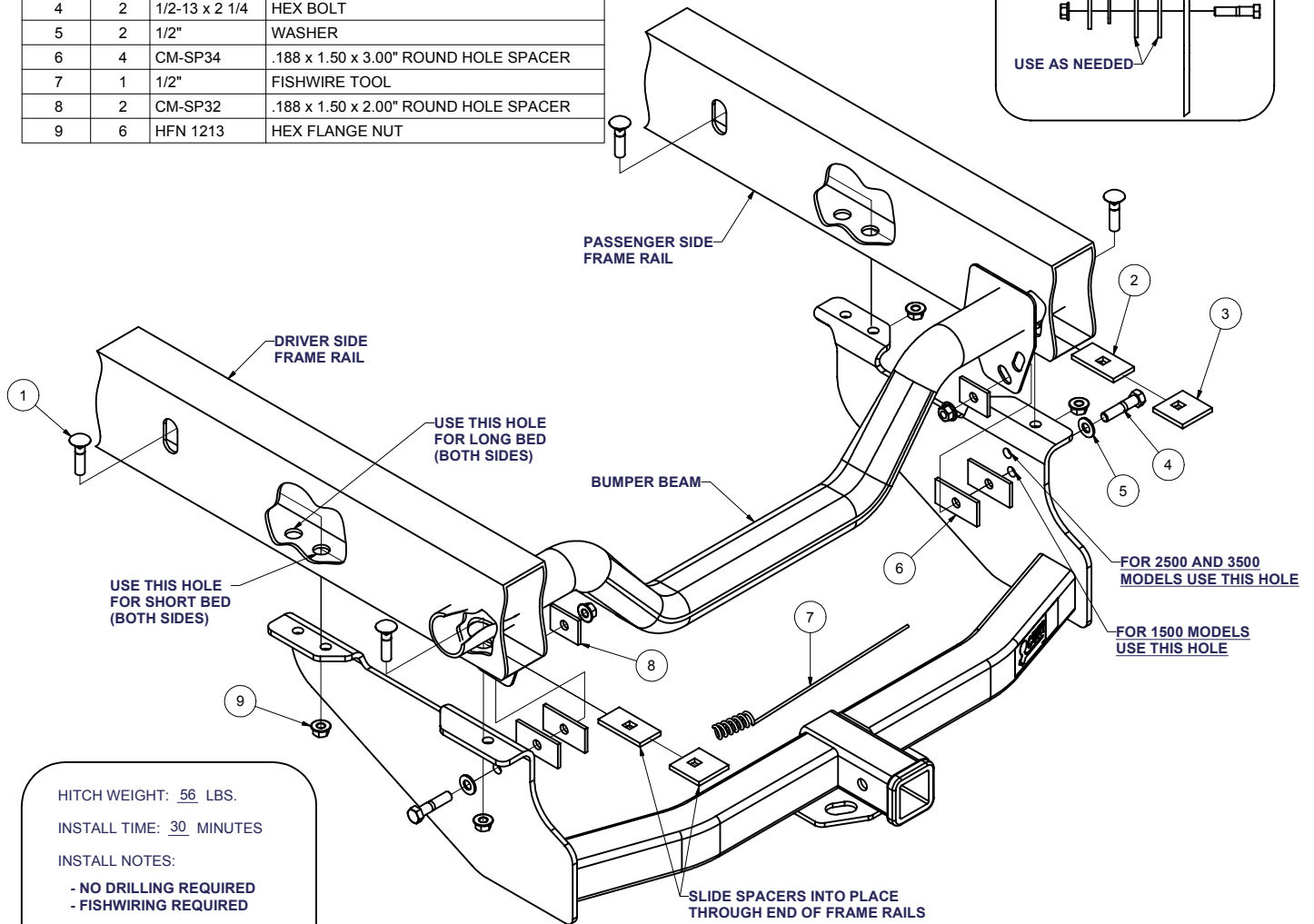
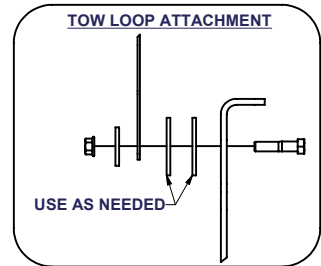

HITCH WEIGHT: 56 LBS.

INSTALL TIME: 30 MINUTES

INSTALL NOTES:

- NO DRILLING REQUIRED
- FISHWIRING REQUIRED

INSTALLATION STEPS

- 1) Raise hitch into position, aligning holes in the hitch to holes in the frame. (See diagram above for short vs long box models).
- 2) Insert hex bolts through side plates and into tow loops. Use spacers as needed between hitch and tow loop. Install outer spacer and flange nut as shown for both sides.
- 3) Using a wire or equivalent, slide the square hole spacers into place as shown. Fishwire forward most carriage bolts into position through access slots in frame. Insert rearward most carriage bolts through bumper beam and through hole, into position as shown for each side.
- 4) Install remaining hex flange nuts and torque all 1/2" fasteners to 75 lb-ft.

PERIODICALLY CHECK THIS RECEIVER HITCH TO ENSURE THAT ALL FASTENERS ARE TIGHT AND THAT ALL STRUCTURAL COMPONENTS ARE SOUND.