

15510

1967-1999 FORD PICKUP, FULL SIZE, OLD BODY STYLE
1999 FORD F-450 CAB & CHASSIS, 2WD ONLY

1/13/2011

GROSS LOAD CAPACITY WHEN USED AS A WEIGHT CARRYING HITCH: 15,000 LBS. TRAILER WEIGHT & 1,500 LBS. TONGUE WEIGHT.
GROSS LOAD CAPACITY WHEN USED AS A WEIGHT DISTRIBUTION HITCH: 16,000 LBS. TRAILER WEIGHT & 1,600 LBS. TONGUE WEIGHT

*****DO NOT EXCEED VEHICLE MANUFACTURER'S RECOMMENDED TOWING CAPACITY.*****

Parts List			
ITEM	QTY	PART NUMBER	DESCRIPTION
1	2	CM-SP4	.250 x 1.50 x 3.00" SQUARE HOLE SPACER
2	6	HFN 1213	HEX FLANGE NUT
3	6	1/2-13 x 1 3/4	CARRIAGE BOLT
4	6	CM-SP1	.250 x 1.50 x 2.00" SQUARE HOLE SPACER
5	8	7/16-14 x 1 1/4	CARRIAGE BOLT
6	8	7/16-14	HEX FLANGE NUT

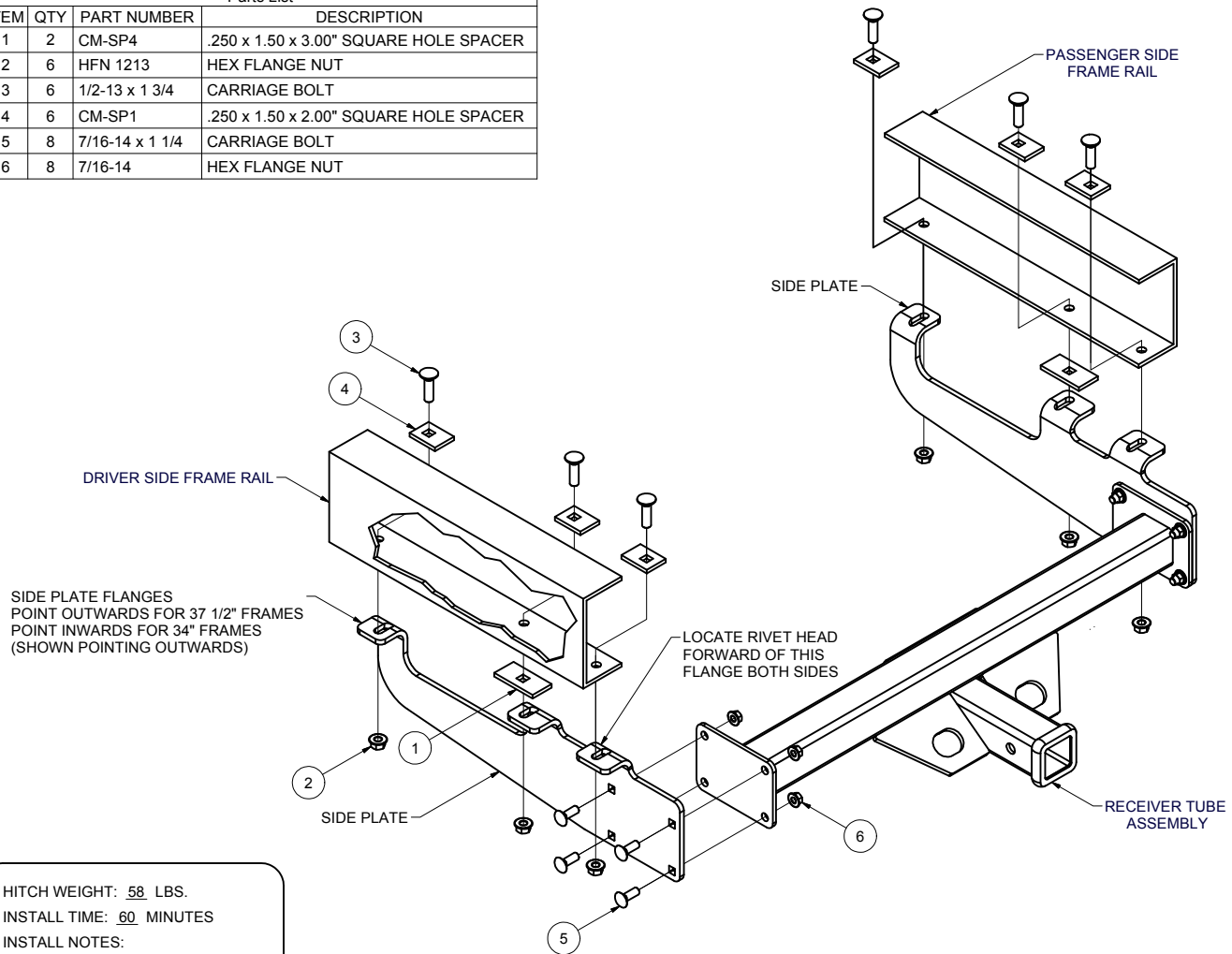

HITCH WEIGHT: 58 LBS.
 INSTALL TIME: 60 MINUTES
 INSTALL NOTES:
 - DRILLING REQUIRED

INSTALLATION STEPS

1. Bolt receiver tube assembly to driver and passenger side plates with 7/16" carriage bolts and hex flange nuts. Side plate flanges should point outwards for 37 1/2" frames and inwards for 34" frames.
2. Loosen spare tire bracket to allow room for positioning the hitch. Position hitch so that the rivet head in the frame rails are located just forward of the rear most side plate flange.
3. Using hitch as a template drill (6) 1/2" holes through frame rails
4. Slide the CM-SP4 spacer in between the hitch side plate and frame rail as shown.
5. Install 1/2" carriage bolts, CM-SP1 spacers and hex flange nuts as shown.
6. Retighten spare tire bracket. Torque 1/2" hardware to 75 lb-ft and 7/16" to 50 lb-ft.

PERIODICALLY CHECK THIS RECEIVER HITCH TO ENSURE THAT ALL FASTENERS ARE TIGHT AND THAT ALL STRUCTURAL COMPONENTS ARE SOUND.

Curt Manufacturing Inc., warrants this product to be free of defects in material and/or workmanship at the time of retail purchase by the original purchaser. If the product is found to be defective, Curt Manufacturing Inc., may repair or replace the product, at their option, when the product is returned, prepaid, with proof of purchase. Alteration to, misuse of, or improper installation of this product voids the warranty. Curt Manufacturing Inc.'s liability is limited to repair or replacement of products found to be defective, and specifically excludes liability for incidental or consequential loss or damage.

15510

DODGE PICKUP, FULL SIZE

1/13/2011

GROSS LOAD CAPACITY WHEN USED AS A WEIGHT CARRYING HITCH: 15,000 LBS. TRAILER WEIGHT & 1,500 LBS. TONGUE WEIGHT.
GROSS LOAD CAPACITY WHEN USED AS A WEIGHT DISTRIBUTION HITCH: 16,000 LBS. TRAILER WEIGHT & 1,600 LBS. TONGUE WEIGHT

*****DO NOT EXCEED VEHICLE MANUFACTURER'S RECOMMENDED TOWING CAPACITY.*****

Parts List			
ITEM	QTY	PART NUMBER	DESCRIPTION
1	2	CM-SP4	.250 x 1.50 x 3.00" SQUARE HOLE SPACER
2	6	HFN 1213	HEX FLANGE NUT
3	6	1/2-13 x 1 3/4	CARRIAGE BOLT
4	4	CM-SP1	.250 x 1.50 x 2.00" SQUARE HOLE SPACER
5	8	7/16-14 x 1 1/4	CARRIAGE BOLT
6	8	7/16-14	HEX FLANGE NUT

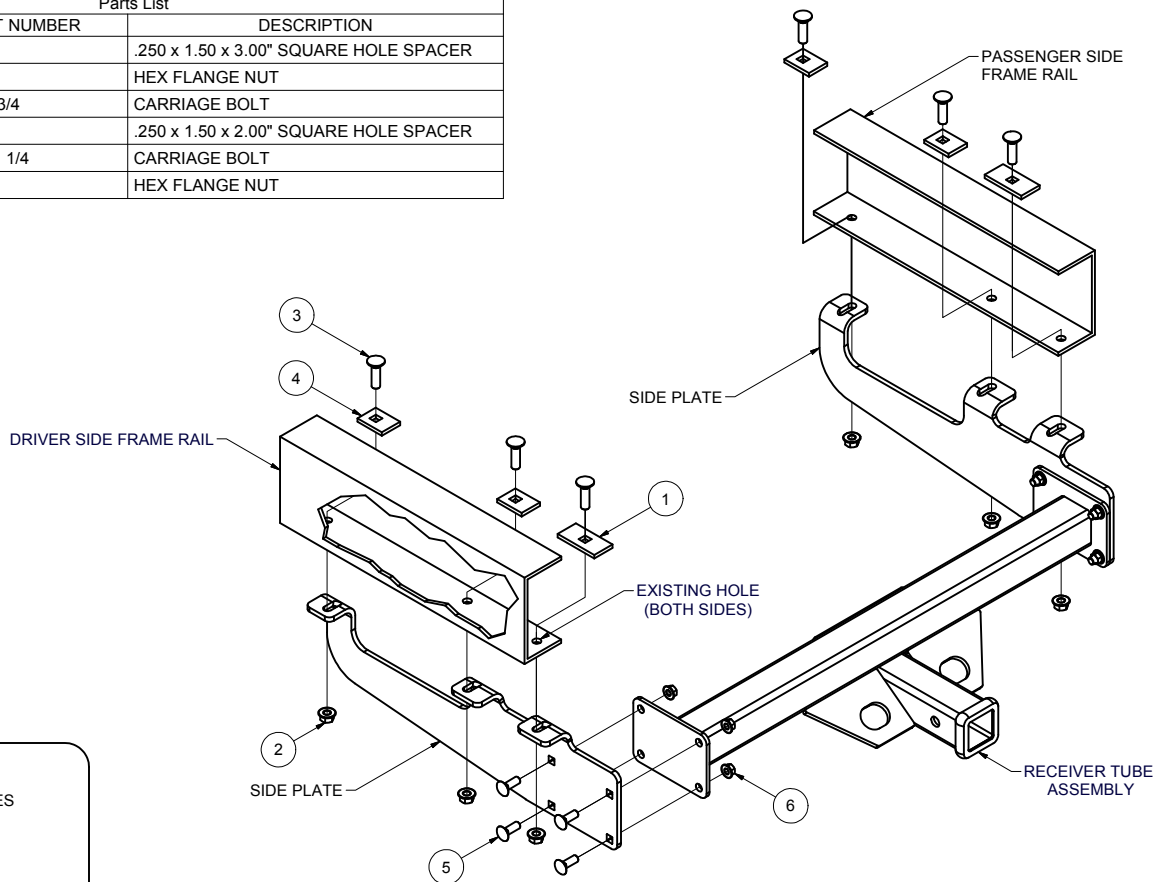

HITCH WEIGHT: 58 LBS.
 INSTALL TIME: 60 MINUTES
 INSTALL NOTES:
 - DRILLING REQUIRED
 - REMOVE SPARE TIRE
 - REMOVE EXHAUST HANGER BRACKET

INSTALLATION STEPS

1. For 1972-1993 vehicles, remove spare tire and hanger bolt. For 1994-1996 vehicles remove rear exhaust hanger bracket.
2. Bolt receiver tube assembly to side plates with 7/16" carriage bolts and nuts. Side plate flanges should point outwards.
3. Locate hitch with the slot of the rear most side plate flange aligned with the large hole in the rear of the vehicle frame rail.
4. Install 1/2" carriage bolt, CM-SP4 spacers, and hex flange nut into the existing hole.
5. Using the hitch as a template, drill 1/2" holes for the remaining hardware.
6. Install remaining 1/2" carriage bolts, CM-SP1 spacers, and hex flange nuts as shown.
7. Torque 1/2" hardware to 75 lb-ft and 7/16" hardware to 50 lb-ft. Reinstall exhaust hanger bracket or spare tire with hanger bolt removed in Step 1. Spare tire cannot be replaced with Dodge 1 ton dually.

PERIODICALLY CHECK THIS RECEIVER HITCH TO ENSURE THAT ALL FASTENERS ARE TIGHT AND THAT ALL STRUCTURAL COMPONENTS ARE SOUND.

Curt Manufacturing Inc., warrants this product to be free of defects in material and/or workmanship at the time of retail purchase by the original purchaser. If the product is found to be defective, Curt Manufacturing Inc., may repair or replace the product, at their option, when the product is returned, prepaid, with proof of purchase. Alteration to, misuse of, or improper installation of this product voids the warranty. Curt Manufacturing Inc.'s liability is limited to repair or replacement of products found to be defective, and specifically excludes liability for incidental or consequential loss or damage.

155101962-1987 CHEVROLET/GMC PICKUP, FULL SIZE, NOT SHORT BOX
1988-1999 CHEVROLET/GMC LONG AND SHORT CAB & CHASSIS, WITH 34" FRAME

1/13/2011

GROSS LOAD CAPACITY WHEN USED AS A WEIGHT CARRYING HITCH: 15,000 LBS. TRAILER WEIGHT & 1,500 LBS. TONGUE WEIGHT.
GROSS LOAD CAPACITY WHEN USED AS A WEIGHT DISTRIBUTION HITCH: 16,000 LBS. TRAILER WEIGHT & 1,600 LBS. TONGUE WEIGHT*****DO NOT EXCEED VEHICLE MANUFACTURER'S RECOMMENDED TOWING CAPACITY.*****

Parts List			
ITEM	QTY	PART NUMBER	DESCRIPTION
1	7	HFN 1213	HEX FLANGE NUT
2	6	1/2-13 x 1 3/4	CARRIAGE BOLT
3	6	CM-SP1	.250 x 1.50 x 2.00" SQUARE HOLE SPACER
4	8	7/16-14 x 1 1/4	CARRIAGE BOLT
5	8	7/16-14	HEX FLANGE NUT
6	1	1/2 - 13 x 1 1/2	HEX BOLT
7	1	CM-SP141	SPARE TIRE "L" BRACKET

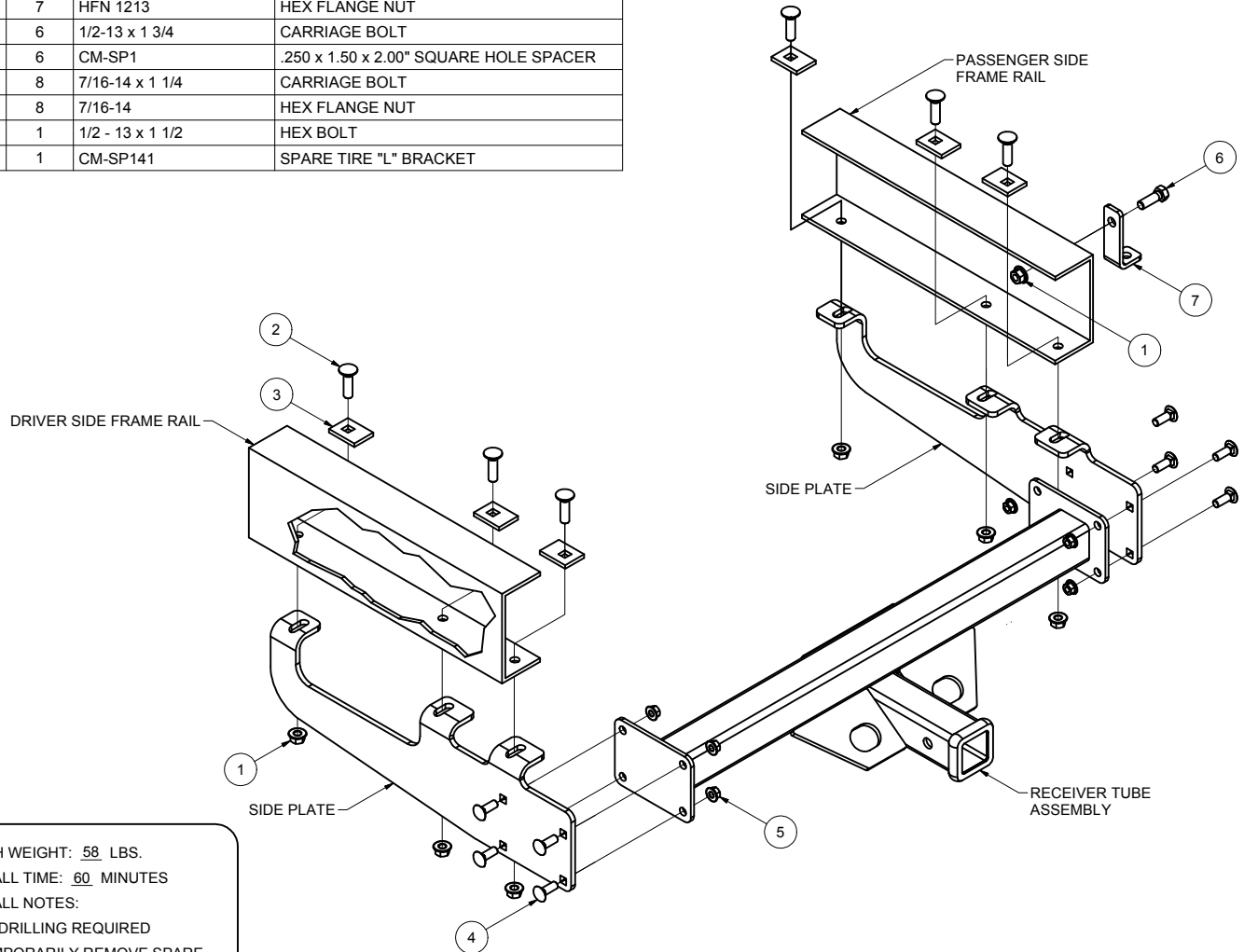

HITCH WEIGHT: 58 LBS.
 INSTALL TIME: 60 MINUTES
 INSTALL NOTES:
 - NO DRILLING REQUIRED
 - TEMPORARILY REMOVE SPARE TIRE

INSTALLATION STEPS

1. Temporarily remove spare tire. Remove and discard bumper reinforcement brackets.
2. Bolt receiver tube assembly to side plates with 7/16" carriage bolts and hex flange nuts. Side plate flanges should point inwards.
3. Insert 1/2" carriage bolts, CM-SP1 spacers, and hex flange nuts as shown.
4. Install CM-SP141 "SPARE TIRE "L" BRACKET" with 1/2" hex bolt and hex flange nut, then install spare tire carrier bolt.
5. Torque 1/2" hardware to 75 lb-ft.
6. Replace spare tire.

PERIODICALLY CHECK THIS RECEIVER HITCH TO ENSURE THAT ALL FASTENERS ARE TIGHT AND THAT ALL STRUCTURAL COMPONENTS ARE SOUND.

Curt Manufacturing Inc., warrants this product to be free of defects in material and/or workmanship at the time of retail purchase by the original purchaser. If the product is found to be defective, Curt Manufacturing Inc., may repair or replace the product, at their option, when the product is returned, prepaid, with proof of purchase. Alteration to, misuse of, or improper installation of this product voids the warranty. Curt Manufacturing Inc.'s liability is limited to repair or replacement of products found to be defective, and specifically excludes liability for incidental or consequential loss or damage.