

16419

2002 - 2008 DODGE 1500 AND 2500 TRUCKS

6/9/2011

EXCLUDES MEGA CAB AND OVERLOAD SPRINGS

\*\*\*DO NOT EXCEED VEHICLE MANUFACTURER'S RECOMMENDED TOWING CAPACITY.\*\*\*

Parts List			
ITEM	QTY	PART NUMBER	DESCRIPTION
1	2	1/2-13 x 4	CARRIAGE BOLT
2	6	1/2-13 x 2 1/2 LG.	CARRIAGE BOLT
3	8	CM-SP136	.313" x 1.00 x 2.00" U-SHAPE SPACER
4	6	CM-SP33	.250 x 1.50 x 2.00" SQUARE HOLE SPACER
5	16	HFN 1213	HEX FLANGE NUT
6	6	CM-16419-YTS	PIPE, SCH. 40 X .500 ID YELLOW TUBE SPACER
7	2	CM-SP4	.250 x 1.50 x 3.00" SQUARE HOLE SPACER
8	4	CM-16419-WTS	PIPE, SCH. 40 X .500 ID WHITE TUBE SPACER
9	8	1/2-13 x 4 1/2	CARRIAGE BOLT
10	4	CM-16419-BTS	PIPE, SCH. 40 X .500 ID BACK TUBE SPACER
11	2	CM-16419-RS	.375" REAR STRAP
12	2	CM-16419-FS	.375" FRONT STRAP
13	2	CM-16419-FSS	.25" FRONT SPACER STRAP

DRILL APPLICATION : NO

APPROX. INSTALL TIME: 100 MIN.

OTHER NOTES:

REMOVE SPARE TIRE, REMOVE EMERGENCY BRAKE HANGER, DETTACH ELECTRICAL HARNESS HANGER PLUGS

DODGE 1500  
1/2 TON

**IMPORTANT**  
USE YELLOW ZINC SPACERS  
ON FRONT MOUNTING STRAPS

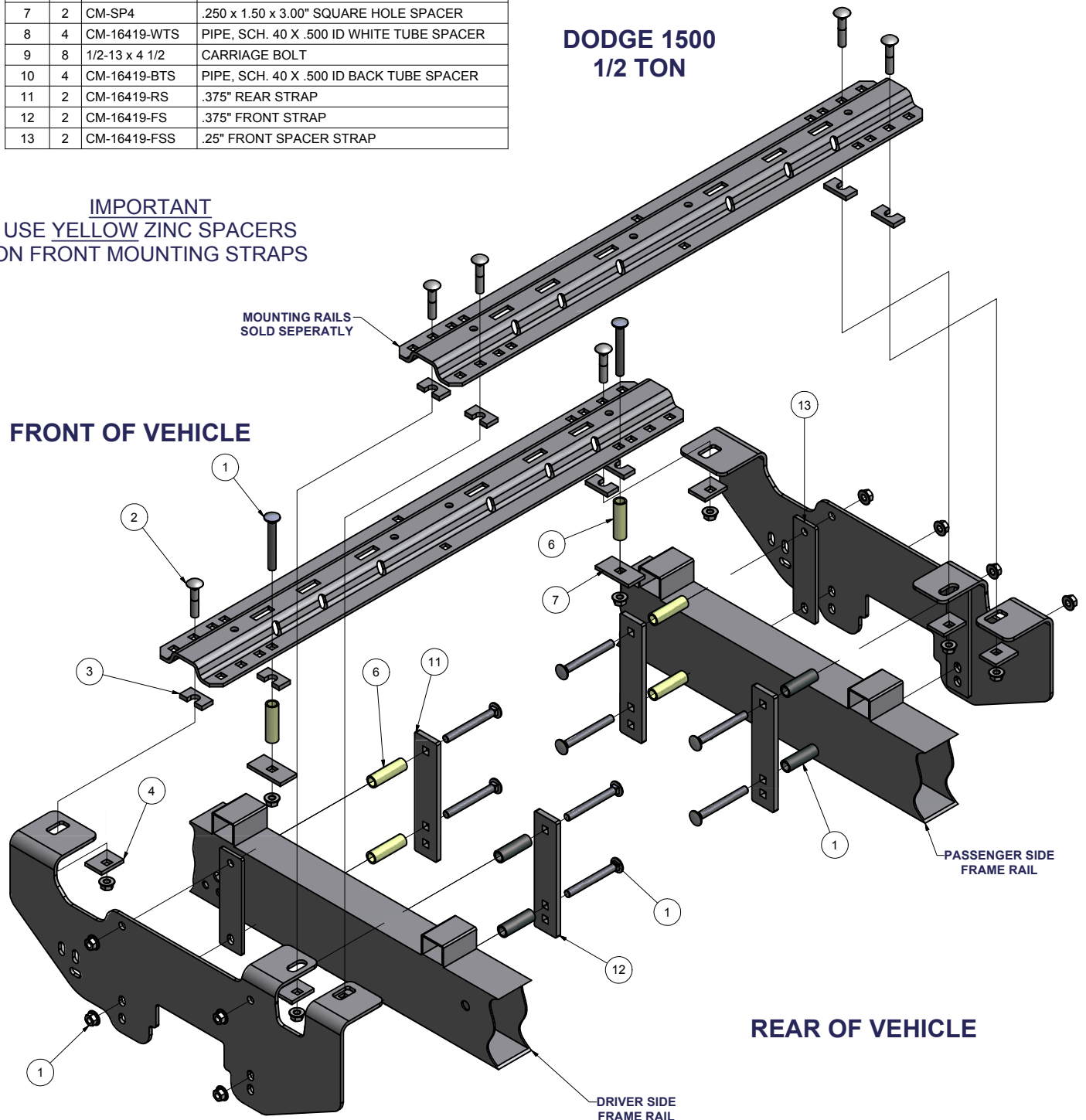

Curt Manufacturing Inc., warrants this product to be free of defects in material and/or workmanship at the time of retail purchase by the original purchaser. If the product is found to be defective, Curt Manufacturing Inc., may repair or replace the product, at their option, when the product is returned, prepaid, with proof of purchase. Alteration to, misuse of, or improper installation of this product voids the warranty. Curt Manufacturing Inc.'s liability is limited to repair or replacement of products found to be defective, and specifically excludes liability for incidental or consequential loss or damage.

16419

2002-2008 DODGE 1500 AND 2500 TRUCKS

EXCLUDES MEGA CAB AND OVERLOAD SPRINGS

\*\*\*DO NOT EXCEED VEHICLE MANUFACTURER'S RECOMMENDED TOWING CAPACITY.\*\*\*

DRILL APPLICATION : NO  
APPROX. INSTALL TIME: 100 MIN.

OTHER NOTES:  
REMOVE SPARE TIRE, REMOVE EMERGENCY BRAKE  
HANGER, DETTACH ELECTRICAL HARNESS HANGER  
PLUGS

Parts List			
ITEM	QTY	PART NUMBER	DESCRIPTION
1	2	1/2-13 x 4	CARRIAGE BOLT
2	6	1/2-13 x 2 1/2 LG.	CARRIAGE BOLT
3	8	CM-SP136	.313" x 1.00 x 2.00" U-SHAPE SPACER
4	6	CM-SP33	.250 x 1.50 x 2.00" SQUARE HOLE SPACER
5	16	HFN 1213	HEX FLANGE NUT
6	6	CM-16419-YTS	PIPE, SCH. 40 X .500 ID YELLOW TUBE SPACER
7	2	CM-SP4	.250 x 1.50 x 3.00" SQUARE HOLE SPACER
8	4	CM-16419-WTS	PIPE, SCH. 40 X .500 ID WHITE TUBE SPACER
9	8	1/2-13 x 4 1/2	CARRIAGE BOLT
10	4	CM-16419-BTS	PIPE, SCH. 40 X .500 ID BACK TUBE SPACER
11	2	CM-16419-RS	.375" REAR STRAP
12	2	CM-16419-FS	.375" FRONT STRAP

**IMPORTANT**  
USE WHITE ZINC SPACERS ON  
FRONT MOUNTING STRAPS

**DODGE 2500**  
**3/4 TON**

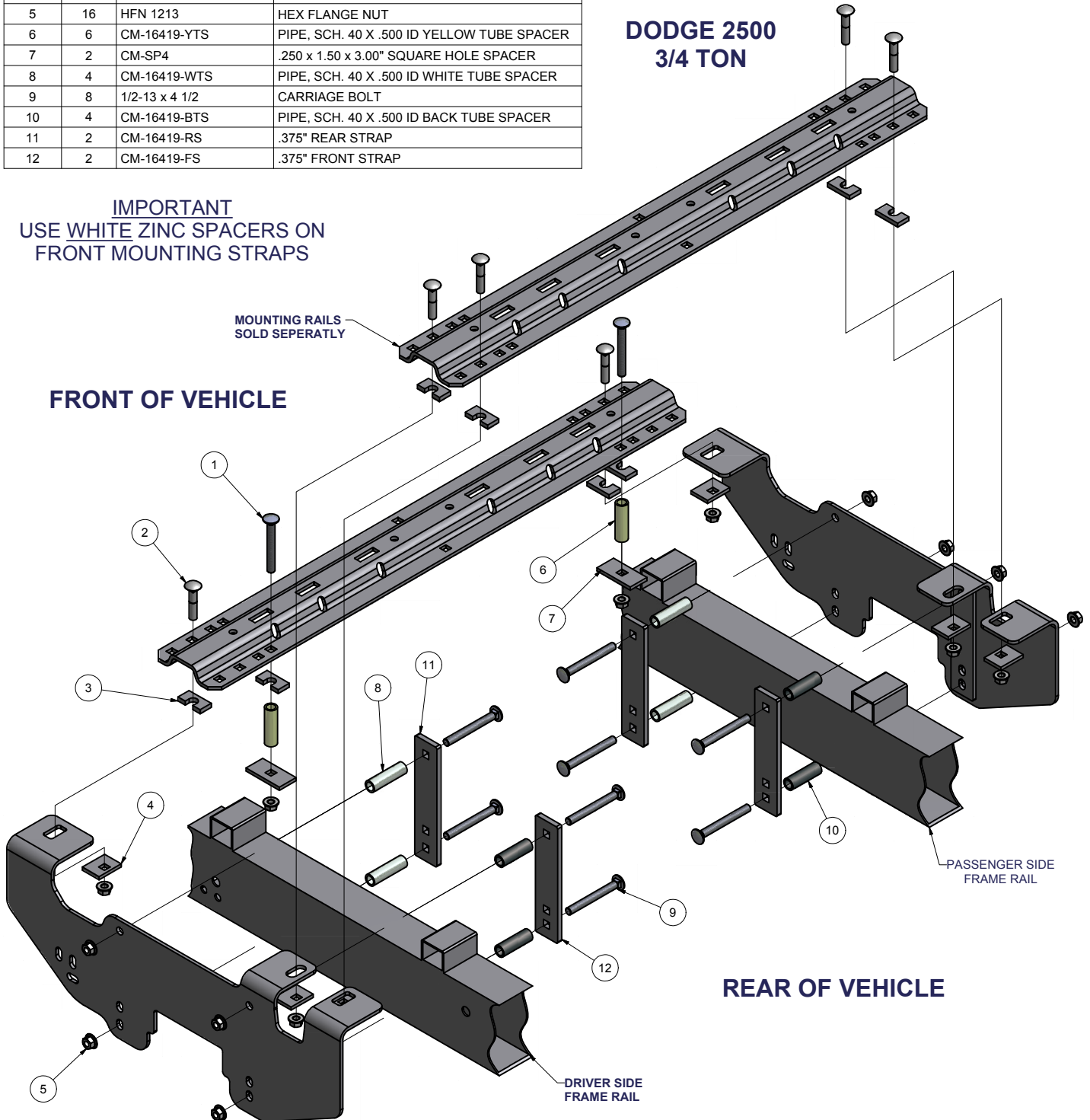

Curt Manufacturing Inc., warrants this product to be free of defects in material and/or workmanship at the time of retail purchase by the original purchaser. If the product is found to be defective, Curt Manufacturing Inc., may repair or replace the product, at their option, when the product is returned, prepaid, with proof of purchase. Alteration to, misuse of, or improper installation of this product voids the warranty. Curt Manufacturing Inc.'s liability is limited to repair or replacement of products found to be defective, and specifically excludes liability for incidental or consequential loss or damage.

# RAIL LOCATION DIAGRAM

**!!IMPORTANT!**  
 SYSTEM MAY NOT WORK WITH  
 2003 AND EARLIER COMPETITOR  
 PRODUCTS

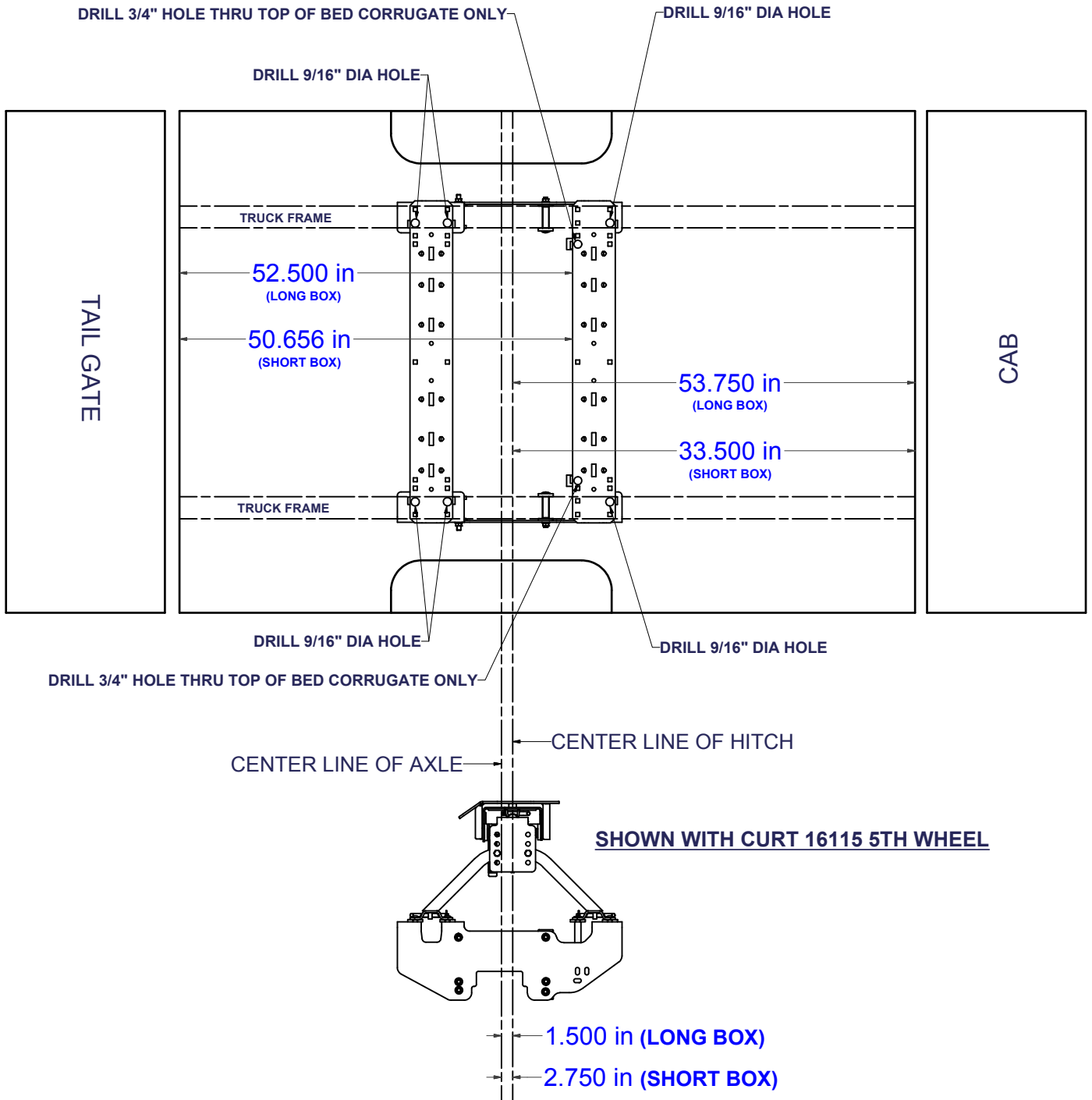

Curt Manufacturing Inc., warrants this product to be free of defects in material and/or workmanship at the time of retail purchase by the original purchaser. If the product is found to be defective, Curt Manufacturing Inc., may repair or replace the product, at their option, when the product is returned, prepaid, with proof of purchase. Alteration to, misuse of, or improper installation of this product voids the warranty. Curt Manufacturing Inc.'s liability is limited to repair or replacement of products found to be defective, and specifically excludes liability for incidental or consequential loss or damage.

**!WARNING!**

- Do not install mounting rails over plastic bed liners. Plastic liners must be trimmed for metal-to-metal contact. May be installed on spray in liner.
- Use only supplied fasteners for installation.
- Before installing hitch measure to be sure there will be enough clearance between the truck and trailer to allow for turns.
- When drilling, protect the fuel tank by placing a piece of metal between the box support and the fuel tank on the driver side to prevent drilling through the fuel tank, use 4" carriage bolts here only!

- 1) Lower and remove spare tire.
- 2) Remove emergency brake cable hanger in driver side wheel well and keep the hanger and the bolts.
- 3) Detach the 2 electrical harness hanger plugs from the inside driver side of the frame just rear of the fuel tank.

- 4) Using a reciprocating saw or cut off wheel, remove the extension attached to the truck box support beams straddling the frame of the truck. This will insure that the frame brackets can mount to the outside of the truck frame. **(REFER TO FIGURE A)** Enlarge the 3/4" hole in the bed support to a 7/8" hole using a die grinder.

CUT ON DOTTED LINES  
TO REMOVE SHADED AREA  
IF PRESENT ON TRUCK BOX

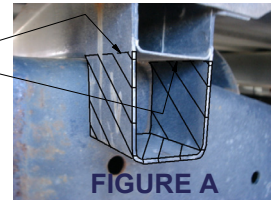

**Note:** This is not a structural part of the truck box and is only used by the manufacturer during assembly.

- 5) Place one mounting rail in the box of the truck, using your tape measure, center the rail between the weld seams on the length of the truck box floor and the proper distance from the rear edge of the truck box as illustrated in "rail location diagram".
- 6) Mark and center punch the holes as per the illustrations. Move the rail out of the way and drill each position with a 1/8" drill bit.
- 7) Temporarily position the frame bracket on the outside of the frame and check that the 1/8" drilled holes align with the slots of the frame bracket. Remove the frame bracket from the vehicle.
- 8) Enlarge the 1/8" drilled holes to the hole sizes stated in the illustrations with the step drill.
- 9) When installing the bushings into the box supports, place the bushing on the 1/2" drill bit and insert them into the predrilled 7/8" hole. Drill a 1/2" hole thru the bottom of the box support using the bushing as a guide. When completed remove the drill and bushing and re-drill the 1/2" hole with the 9/16" drill bit.
- 10) Loosely install frame brackets by attaching the straps, collars, carriage bolts, brackets and nuts. (see illustrations)
 

**Note:** Be sure to use the colored bushing and straps in front and the black in the rear. The front spacer strap is only required on the 1500 applications.
- 11) Loosely install the emergency brake cable hanger with the original hardware.
- 12) Move the mounting rail into position and rotate it up on its edge, insert the 4" long carriage bolts into the rail and place the front bushings over the bolts. Holding on to the bushings rotate the rail into position while inserting the bushing and bolt into the holes.
- 13) Install the 2 1/2" carriage bolts with the U-shaped spacer to be located in the corrugation between the box and the mounting rail. This insures a metal contact. Attach with spacers and nuts as per the illustrations and tighten snug to keep the mounting rail from moving.
- 14) Place the unassembled 5th wheel saddles/slider/goose into the already installed mounting rail. Position the second mounting rail with the saddles/slider/goose by inserting the tabs into the mounting rail and pushing the mounting rail tight towards the other mounting rail. Ensure that the mounting rail is centered between the weld seams on the length of the truck box floor. This will position the mounting rail in the correct location and ensure that the 5th wheel will have a snug fit to the truck.
 

**Note:** If more than one product will be used with the rails then both should be used at the same time to align the second rail. This will ensure that on product does not compromise the fit of the other.
- 15) Repeat steps 6, 8 and 13
- 16) Torque all 1/2" fasteners to 75 lb-ft, first torque the mounting rails to the brackets, then torque the brackets to the frame of the truck.
- 17) Tighten the bolts securing the emergency brake cable hanger.
- 18) Secure the wire harness with the wire tie supplied.
- 19) Re-install spare tire

Curt Manufacturing Inc., warrants this product to be free of defects in material and/or workmanship at the time of retail purchase by the original purchaser. If the product is found to be defective, Curt Manufacturing Inc., may repair or replace the product, at their option, when the product is returned, prepaid, with proof of purchase. Alteration to, misuse of, or improper installation of this product voids the warranty. Curt Manufacturing Inc.'s liability is limited to repair or replacement of products found to be defective, and specifically excludes liability for incidental or consequential loss or damage.