

**16420 DODGE RAM 2500/3500 STD AND QUAD CAB, INCL. DUALY WITH OVERLOAD SPRINGS 2003-PRESENT
DODGE RAM MEGACAB 1500 W/6 FT BED /2500/3500, 2006-2008**

8/5/2011

1 of 3

*** DO NOT EXCEED VEHICLE MANUFACTURER'S RECOMENDED TOWING CAPACITY ***

Parts List				
ITEM	QTY	PART NUMBER	DESCRIPTION	
1	10	1/2-13 x 1 3/4	CARRIAGE BOLT	
2	8	CM-SP136	.313" x 1.00 x 2.00 U-SHAPE SPACER	
3	4	CM-SP33	.250 x 1.50 x 2.00 SQ HOLE SPACER	
4	4	1/2"	LOCK WASHER	
5	20	1/2-13	HEX NUT	
6	4	CM-1209-UBS	1/2-13 x 4 x 7.25 x 1 3/4 SQ U-BOLT	
7	2	1/2-13 x 4 1/2	CARRIAGE BOLT	
8	2	CM-16420-TS	TUBE SPACER	
9	16	1/2"	CONICAL TOOTHED WASHER	
10	2	CM-SP4	.250 x 1.50 x 3.00" SQ HOLE SPACER	
11	2	1_2 x 30 FISHWIRE	1/2 x 30 FISHWIRE	
12	1	CM-116415-CT	CABLE TIE 11/64 X 15 50# UV BLACK	

TOOLS REQUIRED
3/4" AND 7/8" WRENCHES
1/8" AND 9/16" DRILL BITS
3/4" AND 7/8" SOCKETS
RATCHET
TORQUE WRENCH
DRILL
CENTER PUNCH
MEASURING TAPE

FISHWIRE TECHNIQUE
 INSERT COILED END OF FISHWIRE TOOL THROUGH HITCH MOUNTING HOLE IN VEHICLE FRAME RAIL AND OUT THE ACCESS HOLE. PASS COILED END OF FISHWIRE THROUGH SPACER AND THREAD BOLT INTO COIL. KINK WIRE TO KEEP SPACER SEPERATE FROM BOLT AS SHOWN. PULL FISHWIRE, SPACER, AND BOLT THROUGH FRAME AND OUT MOUNTING HOLE. USE FISHWIRE TO GUIDE HITCH DURING MOUNTING AND PREVENT LOSS OF BOLT / SPACER INSIDE FRAME RAIL.
NOTE: SOME VEHICLES MAY FISHWIRE THROUGH END OF FRAME

FRONT OF VEHICLE

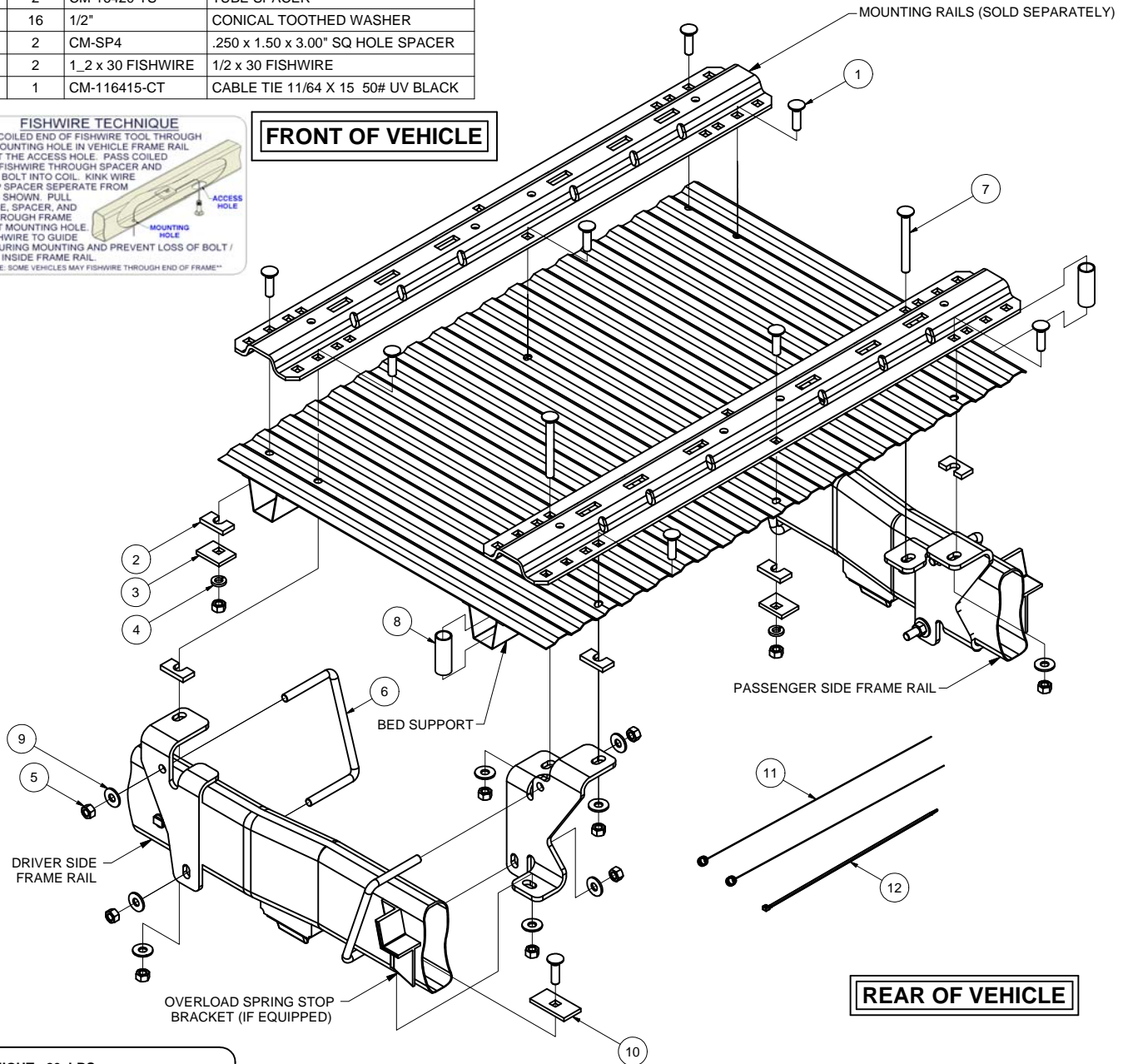

REAR OF VEHICLE

WEIGHT: 26 LBS.
INSTALL TIME: 90 MINUTES
INSTALL NOTES:
 - NO DRILLING REQUIRED
 - FISHWIRE HARDWARE

FIGURE 1: ASSEMBLY DIAGRAM

Curt Manufacturing Inc., warrants this product to be free of defects in material and/or workmanship at the time of retail purchase by the original purchaser. If the product is found to be defective, Curt Manufacturing Inc., may repair or replace the product, at their option, when the product is returned, prepaid, with proof of purchase. Alteration to, misuse of, or improper installation of this product voids the warranty. Curt Manufacturing Inc.'s liability is limited to repair or replacement of products found to be defective, and specifically excludes liability for incidental or consequential loss or damage.

**16420 DODGE RAM 2500/3500 STD AND QUAD CAB, INCL. DUALY WITH OVERLOAD SPRINGS 2003-PRESENT
DODGE RAM MEGACAB 1500 W/6 FT BED /2500/3500, 2006-2008**

8/5/2011

2 of 3

WARNING:

- Do not install mounting rails over plastic bed liners. Plastic liners must be trimmed for metal to metal contact. (Mounting rails may be installed on spray on liner.)
- Use only supplied fasteners for installation.
- Before installing mounting rails and hitch, measure to be sure there will be enough clearance between the truck and trailer to allow for turns.

Installation Instructions:

1. Lower and remove the spare tire.
2. Detach the wire harness from inside of the driver side frame between the fuel tank and the shock absorber mount.
3. Place the rear mounting rail in the box of the truck. Using a tape measure, center the rail between the box sides and perpendicular to the length of the vehicle. Position the rail at the proper distance from the rear edge of the truck box as shown in Figure 2.
- 4a. Mark and center punch the bolt positions as per the illustration in Figure 2. Move rail out of the way, drill (2) 1/8" holes in Row 2. Check hole location to see if hole is in the center of the rear bed support. Hold rear frame brackets in place to verify the the holes in the bottom of the frame rails will match with slots in brackets.
- 4b. Reposition rear rail in place and measure 22" on center from rear to front rails. Drill 1/8" hole in Row 3. Check location of front hole in relation to bed support to be sure there is space for the fasteners to be secured. This process is to verify that the hole locations are correct due to bed support location variances.
- 4c. If an interference issue exists with the front bed support, it will be necessary to shift the location of the holes and brackets towards the rear of the vehicle. Shift the rear brackets toward the rear of the vehicle while checking that the supplied hardware will still pass through the brackets and into the existing hole in the bottom of the frame rail. Mark and drill new hole locations through rear frame brackets. Verify bed support clearance similar to Step 4b. Repeat this entire process as necessary.
WARNING: When drilling holes be aware of potential risks to vehicle components and make appropriate safe guards to protect them from damage.
5. Temporarily position the frame brackets on the outside of the frame and check that the 1/8" drilled holes align with the slots of the frame bracket. Once in position center punch and drill the rest of the holes. Remove the frame brackets from the vehicle.
6. Enlarge the 1/8" drilled holes to 9/16" using a drill and bit.
7. Loosely install the rear frame brackets as follows:
 - a) Place the brackets on the inside of the frame as shown in Figure 1.
 - b) Install a u-bolt on each of the brackets. The u-bolt wraps around the outside of the frame, right behind the rear bed support. Loosely install 1/2" conical toothed washers and hex nuts onto the ends of the u-bolts. **Note: Depending on the vehicle, the exhaust and heat shield may need to be lowered to gain access to the bottom u-bolt end on the passenger side rear frame bracket.**
 - c) Feed a 1-3/4" carriage bolt and 1.50" x 3" spacer into position in the bottom of the frame using a fishwire. There is a round hole in the inside of the frame that can be used to feed the hardware. Loosely fasten the carriage bolt with a 1/2" conical toothed washer and hex nut.
8. Reposition the mounting rail over the holes enlarged in Step 6.
9. Install the 1/2" x 1-3/4" carriage bolts with the u-shaped spacers in the rear holes of the rear brackets. Place the u-shaped spacers between the bracket and the bed to prevent the bed from collapsing when the bolts are tightened.
10. Install the 1/2" x 4-1/2" carriage bolts with the tube spacers in the front holes of the rear brackets. The tube spacers fit inside the bed support, and may be fed in through the end of the bed support with the help of a fish wire looped through the hole in the top of the bed, out the end of the bed support, and back through the hole in the bottom of the bed support. The carriage bolt goes through the middle of the tube spacer, which will keep the bed support from collapsing when the bolts are tightened.
11. Install the 1/2" x 1-3/4" carriage bolt in the center hole of the rear rail as shown in Figure 1. Place a u-shaped spacer between the rail and the bed, and secure the bolt with as 1-1/2" x 2" spacer, 1/2" lock washer and hex nut on the bottom.
12. Place the unassembled 5th wheel saddles / slider / goose into the already installed mounting rail. Position the second mounting rail with saddles / slider / goose by inserting the tabs into the mounting rail and pushing the mounting rail tight towards the other mounting rail. Ensure that the mounting rail is centered between the box sides on the length of the truck box floor. This will position the mounting rail in the correct location and ensure that the 5th wheel will have a snug fit to the truck. **NOTE:** If more than one hitch product will be used with the rails then both should be used at the same time to align the second rail. This will ensure that one product does not compromise the fit of the other.

8/5/2011

3 of 3

WARNING:

- Do not install mounting rails over plastic bed liners. Plastic liners must be trimmed for metal to metal contact. (Mounting rails may be installed on spray in liner.)
- Use only supplied fasteners for installation.
- Before installing mounting rails and hitch, measure to be sure there will be enough clearance between the truck and trailer to allow for turns.

Installation Instructions:

13. Repeat Steps 4, 5 and 6 using the front frame brackets. The front edge of the bracket should be just behind the front bed support.
14. **Loosely install the front frame brackets as follows:**
 - a) Place all of the brackets on the outside of the frame as shown in Figure 1.
 - b) Secure each of the brackets with a u-bolt, 1/2" conical toothed washers and hex nut as shown.
Note: The u-bolt on the driver side must be placed between the brake line and the frame. Improper placement of the driver side u-bolt may result in damage to the vehicle's braking system.
15. Install the 1/2" x 1-3/4" carriage bolts and u-shaped spacers in the front rail as shown in Figure 1. Place the u-shaped spacers between the rail and the bed. To attach the carriage bolts to the front frame brackets, use 1/2" conical toothed washers and hex nuts. To attach the other carriage bolts to the bed use 1-1/2" x 2" spacers, 1/2" lock washers and hex nuts.
16. Torque the fasteners to 75 lb-ft in the following sequence: 1) Torque the mounting rails to the frame brackets. 2) Torque the frame brackets to the truck frame.
17. Reattach the wire harness to the inside of the passenger side frame. If necessary, use the supplied cable tie.
18. Reinstall the spare tire. (Also reinstall the exhaust and heat shield at this time if lowered in Step 7.)

FIGURE 2: RAIL LOCATION DIAGRAM