

*****DO NOT EXCEED VEHICLE MANUFACTURER'S RECOMMENDED TOWING CAPACITY.*****

Parts List			
ITEM	QTY	PART NUMBER	DESCRIPTION
1	1	CM-16437-DS	.250" DRIVER SIDE PLATE
2	1	CM-16437-PS	.250" PASSENGER SIDE PLATE
3	2	3_4 - 10 x 1 1_2 HEX	HEX BOLT
4	4	3_4 WASHER	.750 STANDARD WASHER
5	2	3/4-10	HEX FLANGE NUT
6	10	HFN 1213	HEX FLANGE NUT
7	6	CM-SP33	.250 x 1.50 x 2.00" SQUARE HOLE SPACER
8	2	1/2-13 x 1 1/2	CARRIAGE BOLT
9	4	CM-SP12	.250 x 1.00 x 2.00" SQUARE HOLE SPACER
10	8	CM-SP136	.313" x 1.00 x 2.00" U-SHAPE SPACER
11	8	1/2 - 13 x 2"	CARRIAGE BOLT
12	1	M8 - 1.25 x 30 TAP BOLT	HEX HEAD TAP BOLT
13	1	3/8"	CONICAL TOOTHED WASHER

DRILL APPLICATION : NO
APPROX. INSTALL TIME: 120 MIN.

OTHER NOTES:
LOWER SPARE TIRE, REMOVE EXHAUST, REMOVE
PASS. SIDE EXHAUST HANGER, MAY REQUIRE
BRAKE LINE HANGER ATTACHMENT REPLACEMENT

**INSTRUCTIONS FOR ALL
FORD F-150 PICKUPS**

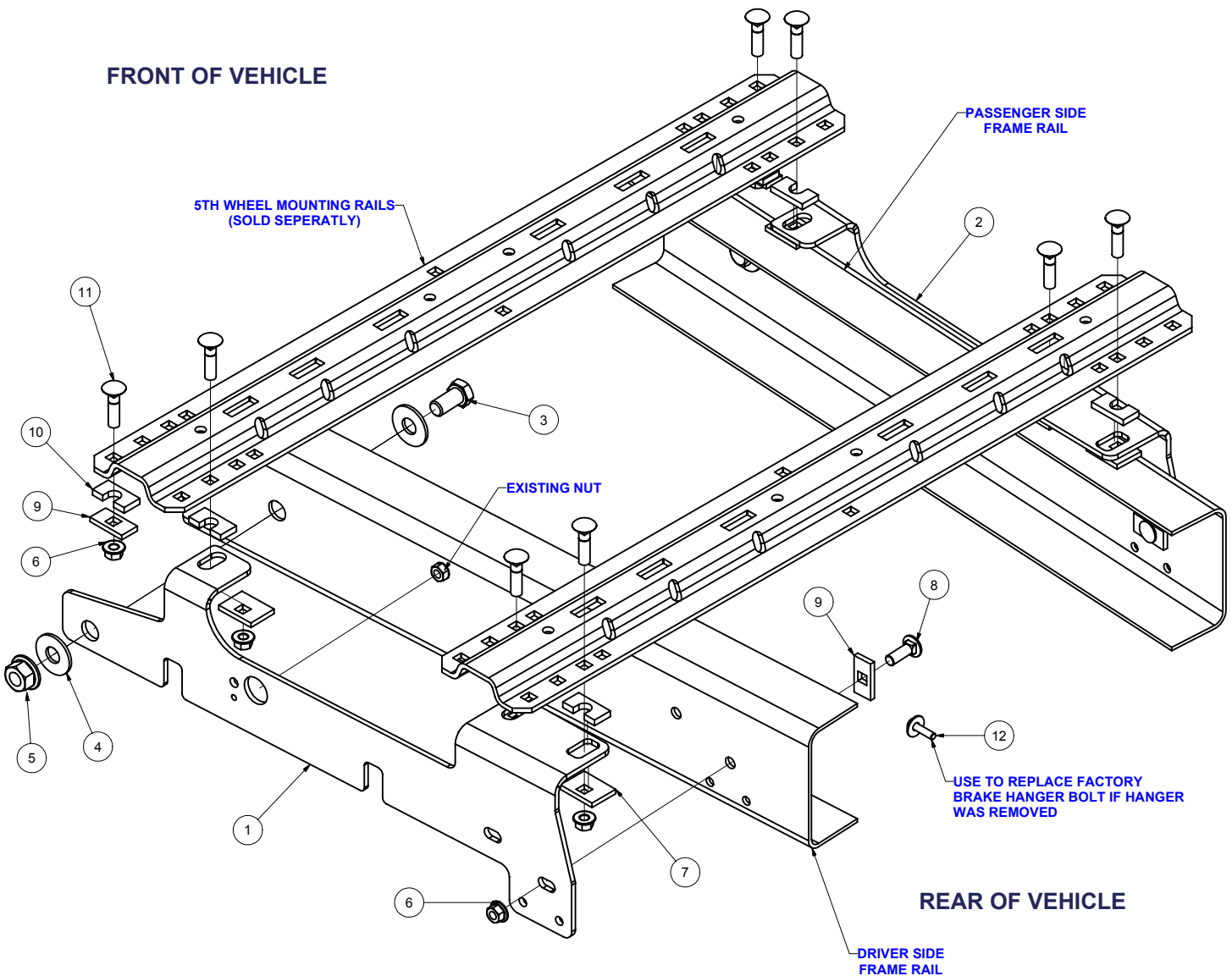

*****DO NOT EXCEED VEHICLE MANUFACTURER'S RECOMMENDED TOWING CAPACITY.*****

Parts List			
ITEM	QTY	PART NUMBER	DESCRIPTION
1	1	CM-16437-DS	.250" DRIVER SIDE PLATE
2	1	CM-16437-PS	.250" PASSENGER SIDE PLATE
3	2	3_4 - 10 x 1 1_2 HEX	HEX BOLT
4	4	3_4 WASHER	.750 STANDARD WASHER
5	2	3/4-10	HEX FLANGE NUT
6	10	HFN 1213	HEX FLANGE NUT
7	6	CM-SP33	.250 x 1.50 x 2.00" SQUARE HOLE SPACER
8	2	1/2-13 x 1 1/2	CARRIAGE BOLT
9	4	CM-SP12	.250 x 1.00 x 2.00" SQUARE HOLE SPACER
10	8	CM-SP136	.313" x 1.00 x 2.00" U-SHAPE SPACER
11	8	1/2 - 13 x 2"	CARRIAGE BOLT
12	1	M8 - 1.25 x 30 TAP BOLT	HEX HEAD TAP BOLT
13	1	3/8"	CONICAL TOOTHED WASHER

DRILL APPLICATION : NO
APPROX. INSTALL TIME: 120 MIN.

OTHER NOTES:
LOWER SPARE TIRE, REMOVE EXHAUST, REMOVE
PASS. SIDE EXHAUST HANGER, MAY REQUIRE
BRAKE LINE HANGER ATTACHMENT REPLACEMENT

**INSTRUCTIONS FOR FORD
F-250 LIGHT DUTY PICKUPS**

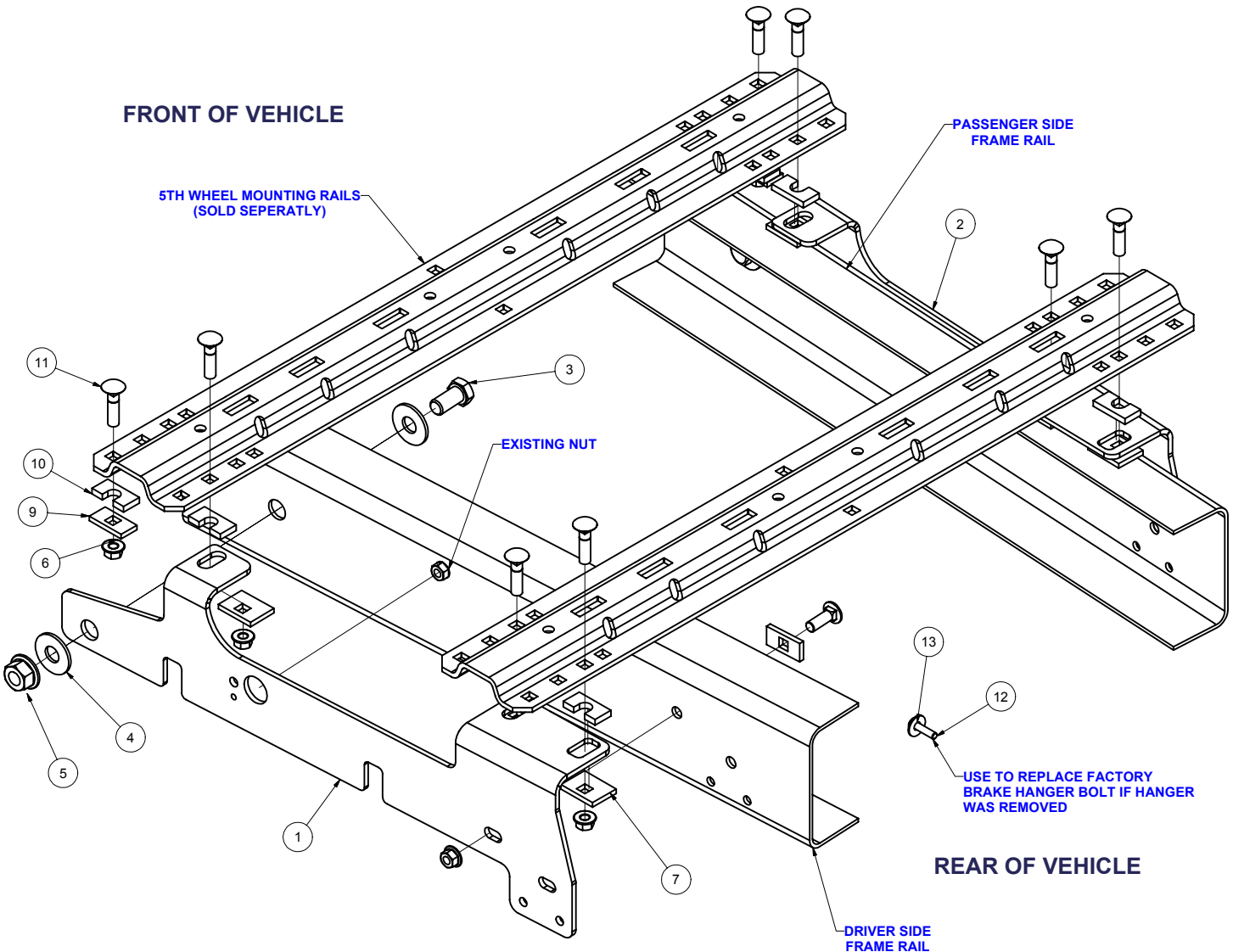

*****DO NOT EXCEED VEHICLE MANUFACTURER'S RECOMMENDED TOWING CAPACITY.*****

RAIL LOCATION DIAGRAM

!!IMPORTANT!
 SYSTEM MAY NOT WORK WITH
 2003 AND EARLIER COMPETITOR
 PRODUCTS

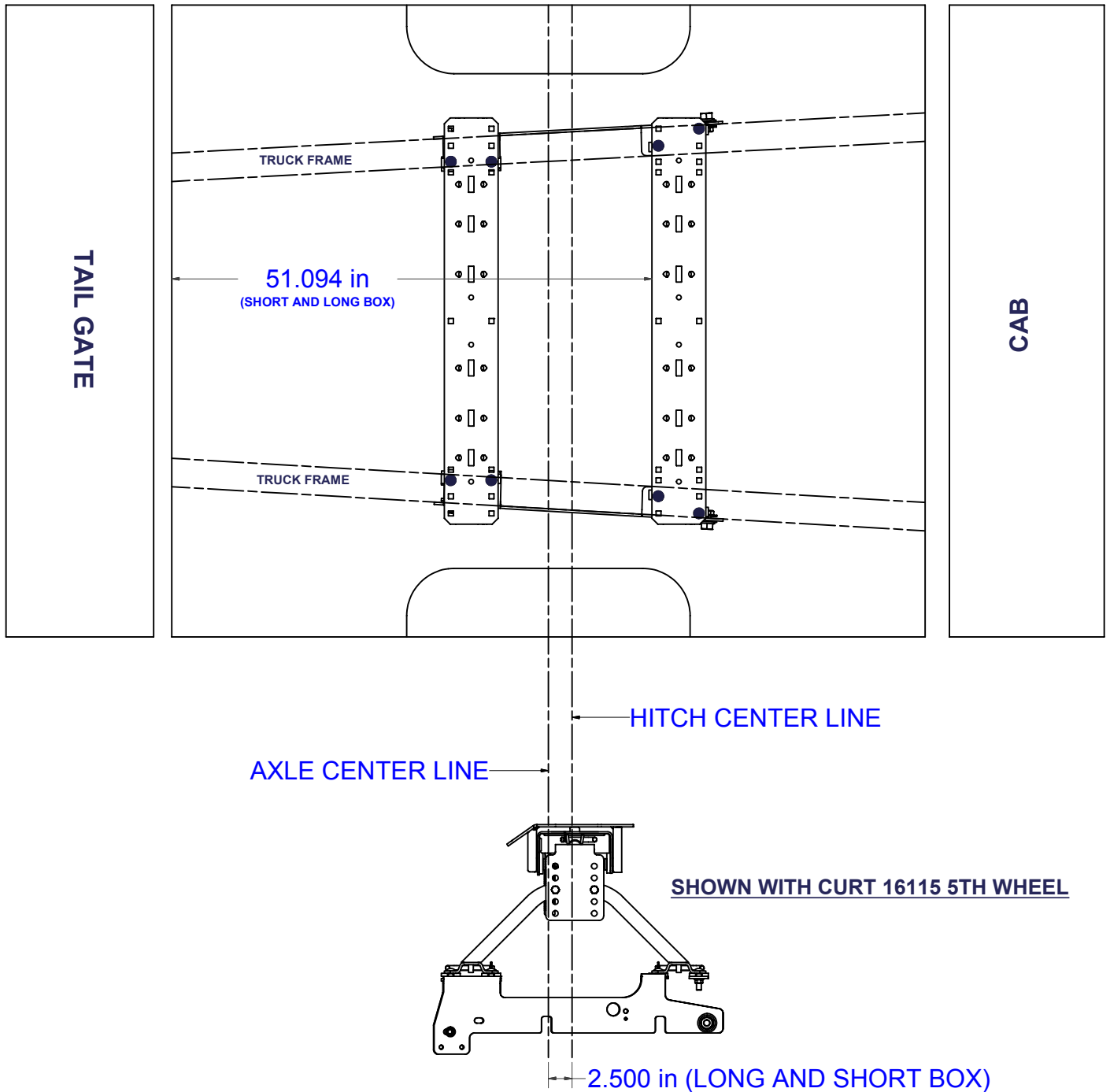

Curt Manufacturing Inc., warrants this product to be free of defects in material and/or workmanship at the time of retail purchase by the original purchaser. If the product is found to be defective, Curt Manufacturing Inc., may repair or replace the product, at their option, when the product is returned, prepaid, with proof of purchase. Alteration to, misuse of, or improper installation of this product voids the warranty. Curt Manufacturing Inc.'s liability is limited to repair or replacement of products found to be defective, and specifically excludes liability for incidental or consequential loss or damage.



5/14/07

16437

FORD LIGHT DUTY FULL SIZE

*****DO NOT EXCEED VEHICLE MANUFACTURER'S RECOMMENDED TOWING CAPACITY.*****

!WARNING!

- Do not install mounting rails over plastic bed liners. Plastic liners must be trimmed for metal-to-metal contact. May be installed on spray in liner.
- Use only supplied fasteners for installation.
- Before installing hitch, measure to be sure there will be enough clearance between the truck and trailer to allow for turns.
- When drilling, protect the fuel tank and filler tubes, brake lines, and wire harness by placing a piece of metal between the box floor and potential components at risk on the driver side. This will prevent drilling into these items.

- 1) Lower and remove spare tire. Remove exhaust heat shield. On passenger side temporarily remove exhaust hanger from side of frame. Some models will require the brake line hanger mounted on the driver side to be temporarily removed.
- 2) Place one rail in the box of the truck, using your tape measure, center the mounting rail on the truck box floor and the proper distance from the rear edge of the truck box as shown.
- 3) Using a center punch, mark the holes as shown. Move the mounting rail out of the way and drill each position with a 1/8" drill bit.

Warning: When drilling front hole on driver side, be careful not to drill into fuel lines.

- 4) Temporarily position the side plate on the side of the frame and check that the 1/8" drilled holes align with the slots of the side plate. Remove the side plate from vehicle.
- 5) Enlarge the 1/8" drilled holes to 9/16" with step drill.
WARNING: When drilling front hole on driver side, be very careful not to drill into fuel lines.
- 6) Fasten the side plates to the side of the frame using the supplied fasteners. Tighten hand tight. On F-250 light duty models, the rear hole on the vehicle frame may require enlarging to accept 1/2" hardware.
- 7) Reposition the mounting rail over the holes and fasten the mounting rail to side plates using the supplied carriage bolts. Use the supplied spacers between the side plates using the supplied carriage bolts. Use the supplied spacers between the side plate or mounting rails and the box so as to ensure a metal-to-metal contact. Tighten hand tight.
- 8) Place the unassembled 5th wheel / roller / gooseneck hitch into the already installed mounting rail. Position the second mounting rail with the 5th wheel / roller / gooseneck hitch by inserting the tabs into the mounting rail and pushing the mounting rail tight towards the other mounting rail. Ensure that the mounting rail is centered on the truck box floor. This will position the rail in the correct location and ensure that the 5th wheel will have a snug fit the truck.

Note: If more than one hitch product will be used with the mounting rails then both should be used at the same time to align the second mounting rail. This will ensure that one product does not compromise the fit of the other.

- 9) Repeat steps 3, 5 & 7
- 10) Starting with the carriage bolts that fasten the mounting rails to the side plates, torque all the nuts. Torque the 1/2" hardware to 72 lb-ft, and the 3/4" hardware to 100 lb-ft.
- 11) Using existing hardware, remount the exhaust hanger on the passenger side to the new mounting holes on the bracket. For vehicles that require the removal of the brake line hanger, remount using the supplied longer M8 flange bolt through the side plate.
12. Reinstall heat shield and spare tire.