

\*\*\* DO NOT EXCEED VEHICLE MANUFACTURER'S RECOMENDED TOWING CAPACITY \*\*\*

Hardware List				Parts List			
ITEM	QTY	PART NUMBER	DESCRIPTION	ITEM	QTY	PART NUMBER	DESCRIPTION
1	10	1/2-13 x 2"	HEX BOLT	A	1	16444-PSF	PASSENGER SIDE FRONT PLATE
2	4	1/2-13 x 1 3/4, GR8	CARRIAGE BOLT	B	1	16444-DSFWA	DRIVER SIDE FRONT WELDMENT
3	4	CM-SP12	.250 x 1.00 x 2.00" SQUARE HOLE SPACER	C	1	16444-RCR	REAR CROSS RAIL
4	2	CM-SP16	.250 x 1.50 x 2.00" ROUND HOLE SPACER				
5	4	HFN 1213, GR8	HEX FLANGE NUT				
6	2	CM-SP4	.250 x 1.50 x 3.00" SQUARE HOLE SPACER				
7	10	CM-SP136	.313" x 1.00 x 2.00" U-SHAPE SPACER				
8	10	CM-SP6	.250 x 1.00 x 3.00" SQUARE HOLE SPACER				
9	10	1/2-13	HANDLE NUT				
10	2	1_2 FISHWIRE	1/2" FISHWIRE				
11	3	CM-116415-CT	CABLE TIE 11/64 X 15" 50# UV BLACK				
12	2	5/8-11	HEX FLANGE NUT				
13	2	5_8 WASHER	WASHER				
14	2	5_8 - 11 x 3 1_2 HEX	HEX BOLT				
15	1	16444-ET	EDGE TRIM				

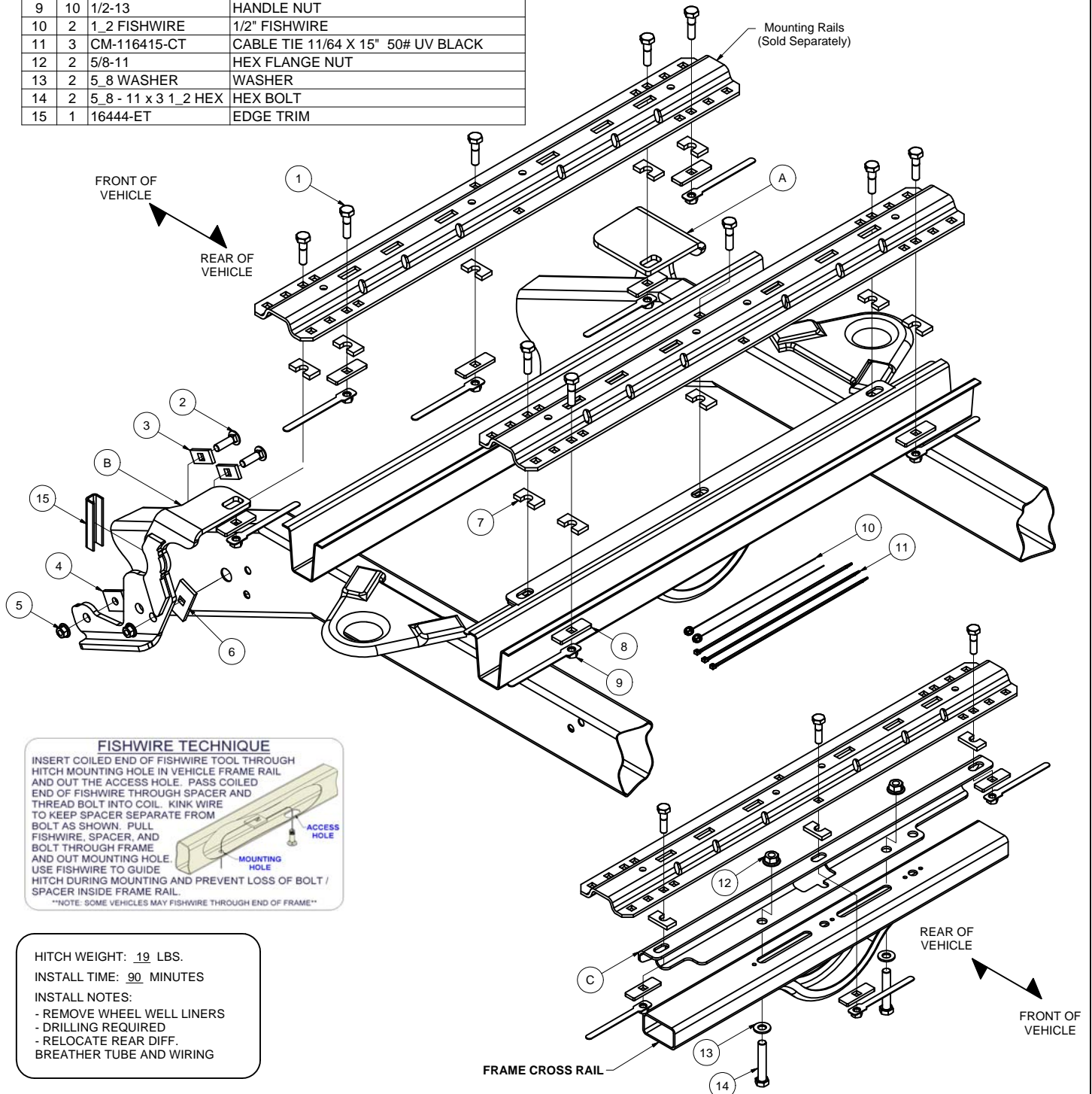

**FISHWIRE TECHNIQUE**  
 INSERT COILED END OF FISHWIRE TOOL THROUGH HITCH MOUNTING HOLE IN VEHICLE FRAME RAIL AND OUT THE ACCESS HOLE. PASS COILED END OF FISHWIRE THROUGH SPACER AND THREAD BOLT INTO COIL. KINK WIRE TO KEEP SPACER SEPARATE FROM BOLT AS SHOWN. PULL FISHWIRE, SPACER, AND BOLT THROUGH FRAME AND OUT MOUNTING HOLE. USE FISHWIRE TO GUIDE HITCH DURING MOUNTING AND PREVENT LOSS OF BOLT / SPACER INSIDE FRAME RAIL.  
\*\*NOTE: SOME VEHICLES MAY FISHWIRE THROUGH END OF FRAME\*\*

HITCH WEIGHT: 19 LBS.  
 INSTALL TIME: 90 MINUTES  
 INSTALL NOTES:  
 - REMOVE WHEEL WELL LINERS  
 - DRILLING REQUIRED  
 - RELOCATE REAR DIFF. BREATHER TUBE AND WIRING

Curt Manufacturing Inc., warrants this product to be free of defects in material and/or workmanship at the time of retail purchase by the original purchaser. If the product is found to be defective, Curt Manufacturing Inc., may repair or replace the product, at their option, when the product is returned, prepaid, with proof of purchase. Alteration to, misuse of, or improper installation of this product voids the warranty. Curt Manufacturing Inc.'s liability is limited to repair or replacement of products found to be defective, and specifically excludes liability for incidental or consequential loss or damage.

## GENERAL INSTRUCTIONS FOR MOUNTING RAIL INSTALLATION

**TOOLS**

3/16" drill  
 17/32" drill  
 1" drill

3/4" Socket & Open End Wrench  
 Torque Wrench  
 "C" Clamps

Tape measure  
 Center punch

1. The following instructions should be used to mount the 5<sup>th</sup> wheel. Care and attention to detail will ensure a quality installation. Check parts against parts list to become familiar with parts in kit. (See pg. 1)
2. Raise rear of truck high enough to allow jack stands to be placed under rear spring hanger bracket of truck. This will provide maximum room to install the 5<sup>th</sup> wheel brackets.

**WARNING:**

**If the truck is raised, be sure that the truck is properly blocked and restrained to prevent the truck from falling. Failure to do so may result in the truck suddenly falling, causing death or serious injury.**

3. Do not install mounting rails over plastic bed liners. Plastic bed liners must be cut out of the way. Mounting rails may be installed on spray in liner. **Note:** Consult installer for recommended curing time.
4. Use only the supplied bolts, nuts, and washers to install this kit.

**CAUTION:**

**These instructions are guidelines only. Actual installation is the responsibility of the installer and the owner. Always measure truck and trailer before installing hitch to be sure that there is clearance at the cab and at the bumper to allow for turns.**

To prevent the trailer from hitting the cab with the trailer turned 90°, the center of the hitch should be at least 52" from the back of the cab when using a long bed truck. (Actual distance required will depend on trailer width and king pin location.) Short bed (Minimum 38" from back cab to axle center line) trucks require a minimum of a 13" extended pin box for regular maneuvers and do not apply.

5. Measurements are given from Rear Edge of truck bed to rear edge of the mounting rail closest to the Rear Edge of truck for most vehicle applications (See Fig. 2).
6. **Center hitch between fender wells and make sure rails are square. Adjust position of rails until both diagonal measurements are the same. This should allow installation of a gooseneck or other 5<sup>th</sup> wheels to these rails (See Fig. 2).**

**CAUTION:**

**Check for obstructions before drilling. Failure to do so could result in damaged fuel Or brake lines, structural members, etc. CURT MANUFACTURING does its best to communicate tow vehicle manufacturer changes; however, it is ultimately the responsibility of the installer to prevent damage due to installation.**

7. Remove plastic inner wheel well liners over rear tires.
8. Place the rearward mounting rail in the bed of the vehicle. Center the rail from left to right on the floor of the truck bed and use your tape measure to locate the proper distance from the rear of the rail to the rear edge of the truck box as illustrated on page 4.
9. Use a center punch to mark the hole in the rail per the illustration. Move the rail out of the way and drill each position through the bed with a 3/16" drill bit. Note: On the driver's side of the vehicle the fuel tank is located below the bed of the vehicle. When drilling holes through the bed be sure not to damage the fuel tank or any other components.

10. For Dual Exhaust vehicles, unbolt the driver's side exhaust hanger from the cross-member and remove.
11. To place the C-channel above the vehicle frame cross member as shown on page 1, temporarily remove the plastic clips that hold the wiring harness to the top of the vehicle frame cross member. Disconnect the electrical connectors from the driver and passenger side behind the cross member and move it out of the way. Remove the rear differential breather tube from the vehicle frame cross member and shock mount. Center the C-channel left to right above the cross member and check to see that the 3/16" drilled holes align with the slots in the C-channel.

**C-channel installation:** To get C-channel into position, slide between the spare tire and the rear axle over the exhaust on the passenger side as far forward as needed to raise the C-channel over the axle. Rest the driver side end on the bump stop mount and the passenger side end on the exhaust pipe, rear of the muffler. Raise the driver side end over the frame of the vehicle, to do this it may need to slide to the passenger side between the passenger side frame rail and the suspension. While raising the passenger side end, slide the C-channel to the driver side. If present, push the air lines over the frame on the passenger and use caution so they are not damaged with the C-channel. Before sliding the C-channel into its final position, insert the passenger side wiring harness plastic clip through the large hole in the C-channel and between the bed sill and cross member. Slide the C-channel into final position and place a zip tie in the center through the large hole to reattach the rear differential breather tube.

12. Enlarge the 3/16" drilled holes to 17/32" with a drill. Paint bare metal as needed.
13. Fasten the C-channel to the vehicle frame cross member as shown on page 1 using 5/8" hardware. Bolt up through the vehicle frame cross member.
14. Reposition the rear mounting rail over the holes in the bed and fasten the mounting rail to the C-channel using the supplied 1/2" hex bolts shown on page 1. Use the supplied U-shaped spacer plates between the C-channel or mounting rail and the truck bed to ensure metal to metal contact.
15. For dual exhaust vehicles, reattach the exhaust hanger that was removed in step 11.

16a. Place the unassembled 5th wheel saddles / slider / goose into the already installed mounting rail. Position the forward mounting rail with saddles / slider / goose by inserting the tabs into the mounting rail and pushing the mounting rail tight towards the other mounting rail. Ensure that the mounting rail is centered between the box sides on the length of the truck box floor. This will position the mounting rail in the correct location and ensure that the 5th wheel will have a snug fit to the truck. Drill the 3/16" holes in Row 1 and 2.

**Note:** If more than one hitch product will be used with the rails then both should be used at the same time to align the second rail. This will ensure that one product does not compromise the fit of the other.

**If hitch attachment is not available use step 16b for rear mounting rail placement**

- 16b. Place the forward mounting rail in the bed of the truck and place 22" on center from forward to rear rails. Center the rail side to side. Center punch the Row 2 hole locations. This process is to verify that the hole locations are correct due to bed support location variances. When aligned, drill the 3/16" holes in Row 1 and 2.
17. Enlarge the 3/16" drilled holes to 17/32" and paint bare metal as needed. Reposition the mounting rails over the holes drilled in the bed.
  18. Install the edge trim (16444-ET) onto the curve section of the drivers side front weldment, next to the fuel fill hose and miscellaneous lines. Install the front frame rail brackets to the frame and forward mounting rail, as shown on page 1. Use the supplied U-shaped spacer plates to ensure metal to metal contact. The brackets install ahead of the bed sill that rests on the frame of the vehicle. Use the 1/2" fishwire to pull the carriage bolts and spacers into the frame.
  19. Starting with the hex bolts that fasten the rails to the frame brackets thru the bed, torque all the nuts. Torque the hex bolts positioned in the center of the rails. Torque the fasteners that attach the frame brackets to the vehicle frame then all remaining fasteners. Torque all 1/2" fasteners to 110 lb-ft and all 5/8" fasteners to 180 lb-ft.
  20. Re-install the wiring harness and the differential breather tube that was removed in step 11. Reinstall plastic wheel well liners.
  21. Zip tie the wires on the driver side frame rail so they are away from moving parts. Zip tie the driver side wiring harness plastic clip to the brake line mount on the driver side under the cross member.

**WARNING:**

**DO NOT lubricate threads. It may cause bolt failure.**

**CAUTION:**

**Check for obstructions before drilling. Failure to do so could result in damaged fuel or brake lines, structural members, etc. CURT MANUFACTURING does its best to communicate tow vehicle manufacturer changes; however, it is ultimately the responsibility of the installer to prevent damage due to installation.**

**CAUTION:**

**It is important that 17/32" drill be used for holes in chassis frame as rib neck bolts may break if too small a hole is used and neck may not grip if too large a hole is used.**

### **Drill locations will vary. See individual installation for location**

Use mounting channel/cross member assembly to position rails (not included).

**\*\* Diagonal Measurements must be the same for smooth  
Operation of 16500 rolling units \*\***

**Fig. 2**

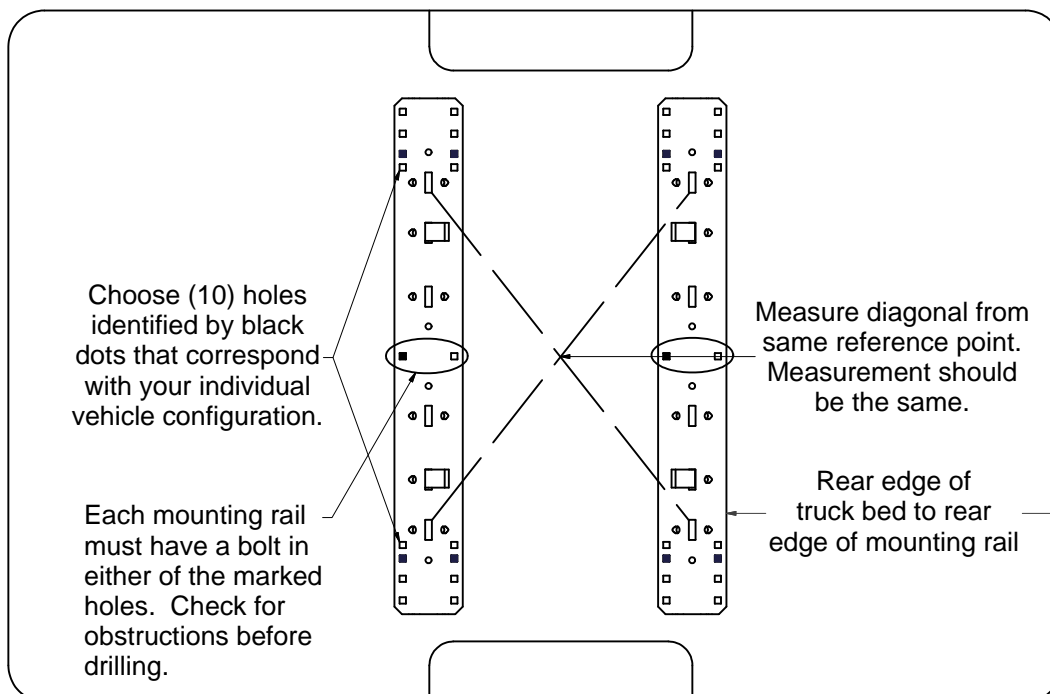

## DODGE / RAM 1500

### IMPORTANT NOTES FOR THIS INSTALLATION:

1. **\*\*Rib neck bolts will need to be pulled through access holes in frame with supplied pull wire (see below).**
2. Do not drill thru both wall of frame. Drill only thru wall of frame to which bracket is mounted.
3. It is very important that brackets in Row 2 are against rear side of Bed Sill as shown. Due to dimensional instability in Bed Sill placement with the Dodge truck, interference could result when drilling in Row 3. Observe caution note below and double check all areas prior to drilling.
4. **\*Due to tubular frames having thinner walls than previous C channel frames, extra caution needs to be used when mounting with the optional welding.**

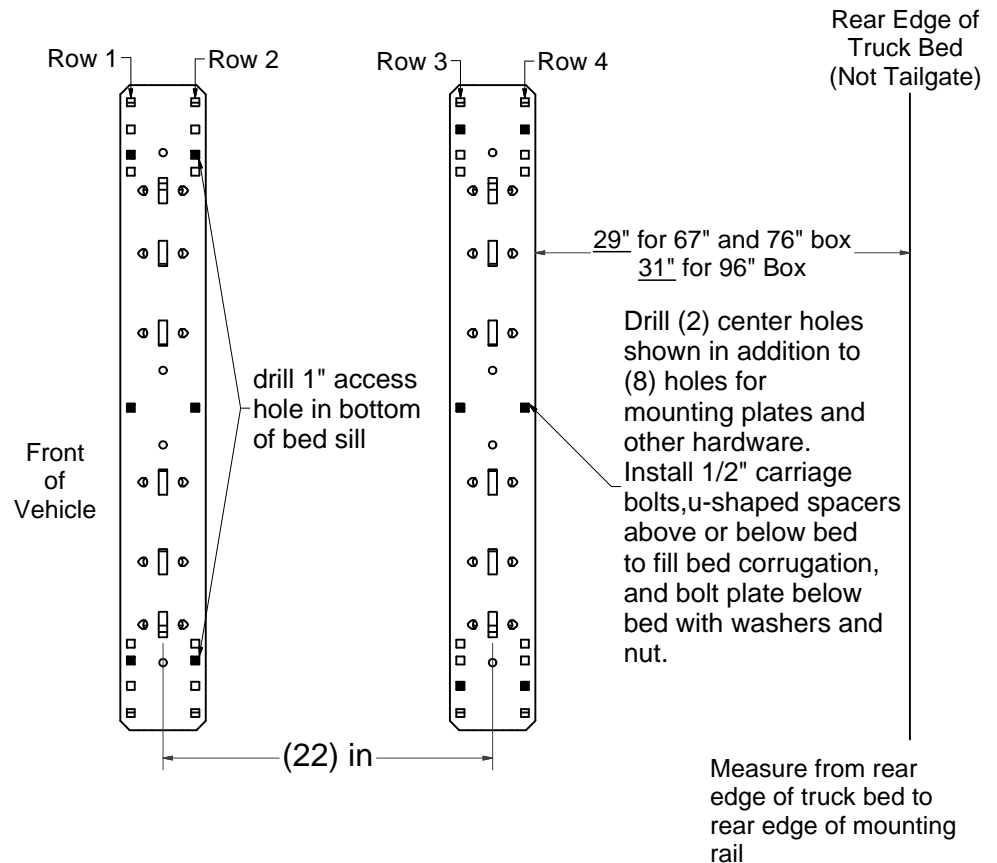

**Check for obstructions before drilling. Failure to do so could result in damaged fuel or brake lines, structural members, etc. CURT MANUFACTURING does its best to communicate tow vehicle manufacturer changes; however, it is ultimately the responsibility of the installer to prevent damage due to installation.**