

INSTALLATION INSTRUCTIONS

VEHICLE

VOLKSWAGEN JETTA

EQUIPMENT REQUIRED:
 WIRING ACCESS LOCATION:
 DRILL BITS: 1/2"
 HITCH REQUIRES 1/2" PIN AND CLIP.
 WRENCHES: (TIGHTEN ALL FASTENERS WITH TORQUE WRENCH) 3/4, 7/8

2000 LB MAX GROSS TRAILER WT
 200 LB MAX TONGUE WEIGHT
 DO NOT EXCEED TOWING VEHICLE RATINGS

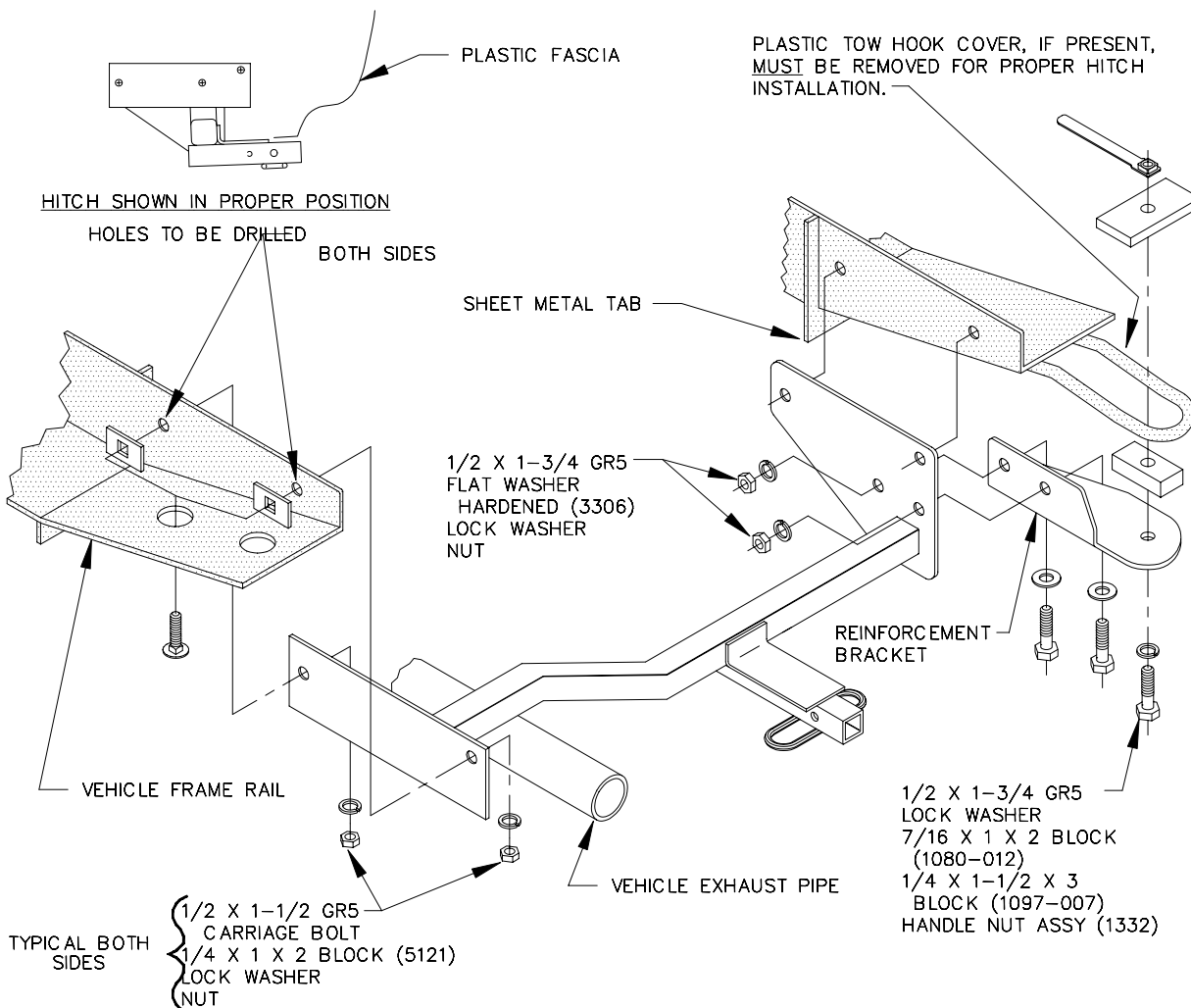

1. RAISE HITCH INTO POSITION SUCH THAT HITCH SIDE BRACKETS CONTACT SHEET METAL TABS ON INBOARD SIDES OF VEHICLE FRAME RAILS AND VEHICLE TRUNK PAN.
 2. USING HITCH AS A TEMPLATE, DRILL TWO (2) HOLES IN INBOARD SIDE OF EACH FRAME RAIL.
 3. FISHWIRE 1/4 X 1 X 2 BLOCKS (5121) AND 1/2 X 1-1/2 CARRIAGE BOLTS THRU LARGE ROUND ACCESS HOLES IN BOTTOM OF FRAME RAIL INTO HOLES DRILLED IN STEP 2.
 4. INSTALL LOCK WASHERS AND NUTS AS SHOWN.
 5. ON PASSENGER'S SIDE, INSTALL REINFORCEMENT BRACKET SUCH THAT TAB FITS THRU PLASTIC FASCIA AND UNDER TOW HOOK. ALIGN HOLES IN REINFORCEMENT BRACKET WITH HOLES IN SIDE BRACKET. INSTALL REMAINING FASTENERS AS SHOWN.
- NOTE:** BLOCKS **MUST** BE ORIENTED AS SHOWN, WITH 7/16 X 1 X 2 (1080-012) INSIDE TOW HOOK, FOR PROPER INSTALLATION.
- NOTE:** IF SHEET METAL INTERFERES WITH REINFORCEMENT BRACKET, TRIM AS NECESSARY.
 TIGHTEN 1/2 GR5 FASTENERS TO 75 LB.-FT.

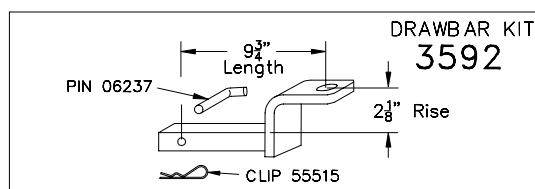

USE ONLY THE DRAWBAR SHOWN FOR CORRECT BUMPER CLEARANCE AND HEIGHT.
 DRAWBAR MUST BE USED IN THE RISE POSITION ONLY.

THIS PRODUCT COMPLIES WITH SAFETY SPECIFICATIONS AND REQUIREMENTS FOR CONNECTING DEVICES AND TOWING SYSTEMS OF THE STATE OF NEW YORK, V.E.S.C. REGULATION V-5 AND SAE J684.

APPROX WEIGHT (LB.)	FASTENER KIT
29	01130-890

NOTE: Check hitch frequently, making sure all fasteners and ball are properly tightened. If hitch is removed, plug all holes in trunk pan or other body panels to prevent entry of water and exhaust fumes. A hitch or ball which has been damaged should be removed and replaced. Observe safety precautions when working beneath a vehicle and wear eye protection. Follow car maker's specs for maximum trailer weight and tongue weight. Do not cut access or attachment holes with a torch.

TOWING PRODUCTS
 Plymouth, Michigan