



Installation Instructions

**PART NUMBERS: 24942, 77329,
 CQT24942**



⚠ WARNING

To prevent SERIOUS INJURY, DEATH or PROPERTY DAMAGE:

- **ALWAYS read, understand and follow warnings and instructions for your hitch BEFORE installation. Keep for future reference.**
- **DO NOT cut, weld or modify this receiver.**
- **CHECK all fasteners are tight and your hitch is securely mounted to your vehicle periodically.**
- **ALWAYS read, understand and follow all warnings and instructions for your vehicle and for other accessories you will use with your hitch BEFORE use.**
- **LOAD the trailer heavier in front.**
- **DO NOT exceed lower of towing vehicle manufacturer's rating or:**

Hitch Type	Max Gross Trailer Weight	Max Tongue Weight
Weight Carrying	2000 lb. (908 kg)	200 lb. (90 kg)
Weight Distributing	X	X

- **ALWAYS wear your seatbelt.**
- **SLOW DOWN when towing, NEVER exceed any posted speed limit.**
- **If EXCESS SWAY occurs, take your foot off the gas pedal and hold the steering wheel as steady as possible. DO NOT apply your brakes and DO NOT speed up.**

LIMITED LIFETIME WARRANTY

1. **Limited Lifetime Warranty (“Warranty”).** Cequent Performance Products, Inc. (“We”, “Us” or “Our”) warrants to the original consumer purchaser only (“You” or “Your”) that the product will be free from material defects in both material and workmanship, ordinary wear and tear excepted. The Warranty is valid only if (a) the products are returned to Us for inspection and testing; (b) Our inspection discloses to Our satisfaction that any alleged nonconformance are material and have not been caused by misuse, neglect, wear and tear, improper installation, unsuitable storage, improper repair, alteration, or accident; and (c) the products were installed, maintained and used in accordance with Our instructions. **THE WARRANTY IS MADE IN LIEU OF ALL OTHER WARRANTIES, EXPRESS OR IMPLIED (OTHER THAN THE WARRANTY OF TITLE AS PROVIDED BY THE UNIFORM COMMERCIAL CODE IN EFFECT IN MICHIGAN), INCLUDING WITHOUT LIMITATION, ANY WARRANTIES OF MERCHANTABILITY OR FITNESS FOR A PARTICULAR PURPOSE, SAID WARRANTIES BEING EXPRESSLY DISCLAIMED.**
2. **Obligations of Purchaser.** To make a Warranty claim, contact Us at our principal address of 47912 Halyard Drive, Suite 100, Plymouth, MI 48170, 1-800-632-3290, identify the product by model number, and follow the claim instructions that will be provided. Any returned product that is replaced by Us becomes our property. You may be responsible for return shipping costs. Please retain your purchase receipt to verify date of purchase and that You are the original consumer purchaser. The product and the purchase receipt must be provided to Us in order to process Your Warranty claim.
3. **Exclusive Remedy.** Product replacement is Your sole and exclusive remedy under this Warranty. We shall not be liable for service or labor charges incurred in removing or replacing a product. **IN NO EVENT WILL WE BE RESPONSIBLE FOR ANY INDIRECT, SPECIAL, CONSEQUENTIAL OR PUNITIVE DAMAGES.**
4. **Assumption of Risk.** You acknowledge and agree that any use of the product for any purpose other than the specified use(s) stated in the product instructions is at Your own risk.
5. **Governing Law.** This Warranty gives You specific legal rights, and You also may have other rights which vary from state to state. This Warranty is governed by the laws of the State of Michigan, without regard to rules pertaining to conflicts of law. The state courts located in Oakland County, Michigan shall have exclusive jurisdiction for any disputes relating to this Warranty.

Rev 9/2014



Installation Instructions

PART NUMBERS: 24942, 77329, CQT24942

Applications:

Years	Make	Models
-------	------	--------

2016-Current*	Acura	TLX
---------------	-------	-----

*Visit our website for the most up to date information regarding application years and trim levels.

Installation Time: **60 Min.**

The time listed above is the average time for professional installers. If you do not feel comfortable performing this installation on your own or are in need of assistance, please contact a professional installer.

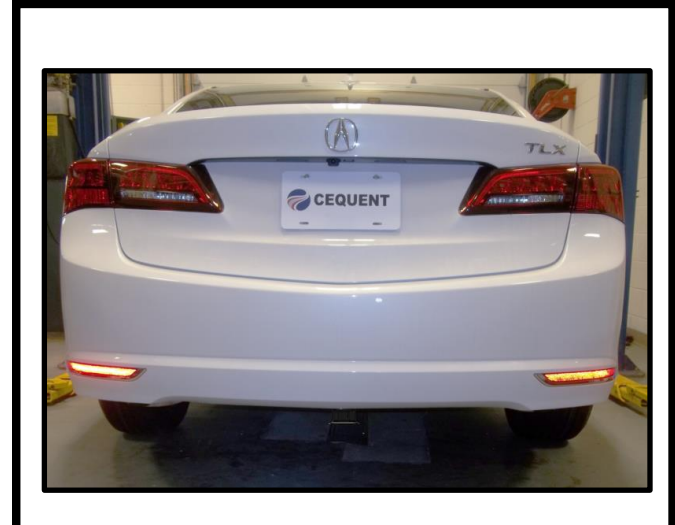

Representative Vehicle Photo

Equipment Required:



DO NOT EXCEED LOWER OF TOWING VEHICLE MANUFACTURER'S RATING OR:

Hitch Type	Max Gross Trailer Weight	Max Tongue Weight
Weight Carrying	2000 lb. (908 kg)	200 lb. (90 kg)
Weight Distributing	X	X

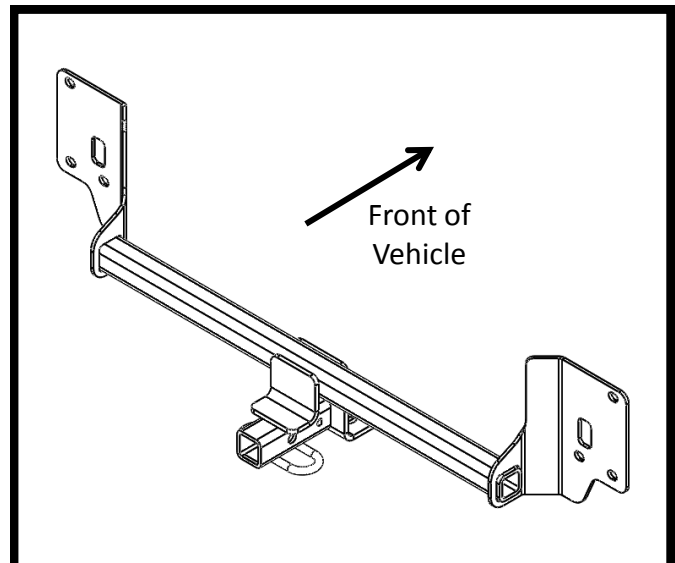

Hitch Illustration

Always wear SAFETY GLASSES when installing hitch



Scan for step by step PHOTO installation instruction or visit <http://www.cequentgroup.com/qr-product.aspx>

Installation Instructions

PART NUMBERS: 24942, 77329, CQT24942

(Sold Separately)

Drawbar Kit:

3593

Drawbar must be used in the **RISE** position only.

Fastener Kit : 24942F

①	Qty. (1)	U-BOLT 3/8-16 GR5	
②	Qty. (2)	Conical washer 3/8"	
③	Qty. (2)	Hex nut 3/8-16	

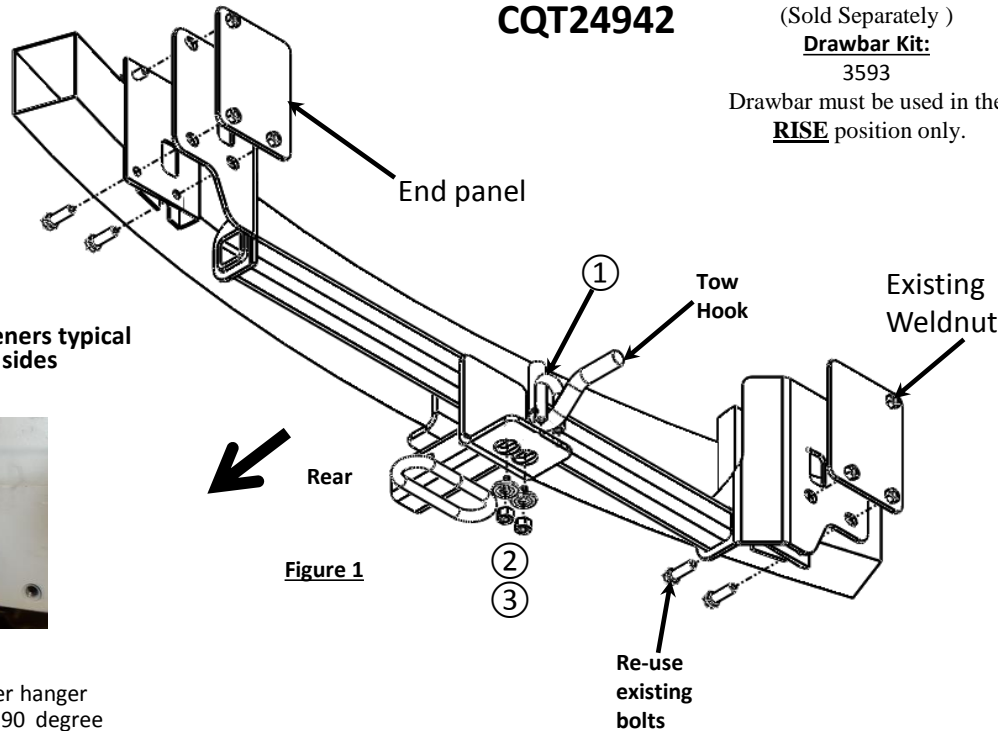

Figure 1

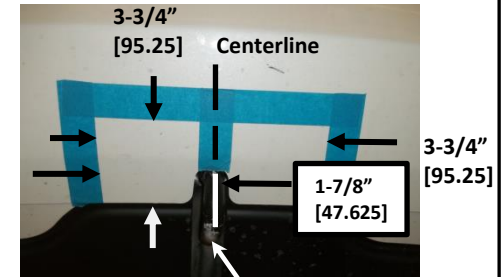

Figure 3

Fascia trimming

Note: Fasteners typical both sides

Teeth side against hitch



Figure 2

Using pliers bend bumper hanger support to approximately 90 degree for clearance.

1. Remove plastic rivet – Remove the (2) plastic rivets that fasten the fascia tabs to the vehicle and trunk pan. Note: Remove the center of the rivet with a flat screwdriver. Keep for re-installation.
2. Open trunk remove tail lights and gasket – remove the plastic cover disc covering the screw on the tail light and fascia attachment to trunk with small screwdriver (3) each side. Remove the fasteners with 10mm socket. Remove lower trunk gasket. To remove tail light gently push rearward on tail lights at the back of the light while gently pulling outward from the forward end. Disconnect the wiring. Set aside.
3. Remove lower rear fascia – remove (2) philip screws in wheel well. Both sides. Remove (1) philip screw each side, located inside fascia at the lower attaching points between rear fascia and rear side panel of vehicle. Both sides. Gently separate the lower fascia trim from the rear side panel pulling the trim upward (if necessary apply minimum pressure to tabs located on the inside of the rear fascia. At the tail lights apply gentle pressure to support bracket tabs. Continue to gently pull on fascia while lifting upward from the bottom of the fascia. Carefully set the rear fascia aside.
4. Remove bumper - remove bumper using 12mm socket (6) bolts. Carefully set the bumper aside. Using pliers bend bumper hanger support to approximately 90 degree for clearance. See Figure 2
5. **Hitch installation** – Hang the U-bolt on the tow hook. Raise the hitch and hang it on the bumper support on the end panel. Raise the bumper to sandwich the hitch, align the holes and reinstall the original bolts removed in step 4. Tighten to hold hitch in place. Install remaining fastener for the tow hook.
6. **Tighten all M8 fasteners with torque wrench to 20 Lb.-Ft. (27 N*M) and all 3/8 GR 5 fasteners with torque wrench to 30 Lb.-Ft. (41 N*M)**
Proper torque is needed to keep the hitch secure to the vehicle when towing.
7. Trim fascia- locate the center of bottom panel (tow hook) and trim 3-3/4" x 3-3/4" wide area, see **Figure 3**. Recommend radius in corners.
8. Re-install fascia - Reinstall all fasteners , fascia and taillights removed in Step 1 - 3.

Note: check hitch frequently, making sure all fasteners and ball are properly tightened. If hitch is removed, plug all holes in trunk pan or other body panels to prevent entry of water and exhaust fumes. A hitch or ball which has been damaged should be removed and replaced. Observe safety precautions when working beneath a vehicle and wear eye protection. Do not cut access or attachment holes with a torch.

This product complies with safety specifications and requirements for connecting devices and towing systems of the state of New York, V.E.S.C. Regulation V-5 and SAE J684.

1. Remove plastic rivet – Remove the (2) plastic rivets that fasten the fascia tabs to the vehicle and trunk pan. Note: Remove the center of the rivet with a flat screwdriver. Keep for re-installation.



2. Open trunk remove tail lights and gasket – remove the plastic cover disc coving the screw on the tail light and fascia attachment to trunk with small screwdriver (3) each side. Remove the fasteners with 10mm socket. Remove lower trunk gasket. To remove tail light gently push rearward on tail lights at the back of the light while gently pulling outward from the forward end. Disconnect the wiring. Set aside.



3. Remove lower rear fascia – remove (2) philip screws in wheel well. Both sides. Remove (1) philip screw each side, located inside fascia at the lower attaching points between rear fascia and rear side panel of vehicle. Both sides. Gently separate the lower fascia trim from the rear side panel pulling the trim upward (if necessary apply minimum pressure to tabs located on the inside of the rear fascia. At the tail lights apply gentle pressure to support bracket tabs. Continue to gently pull on fascia while lifting upward from the bottom of the fascia. Carefully set the rear fascia aside.

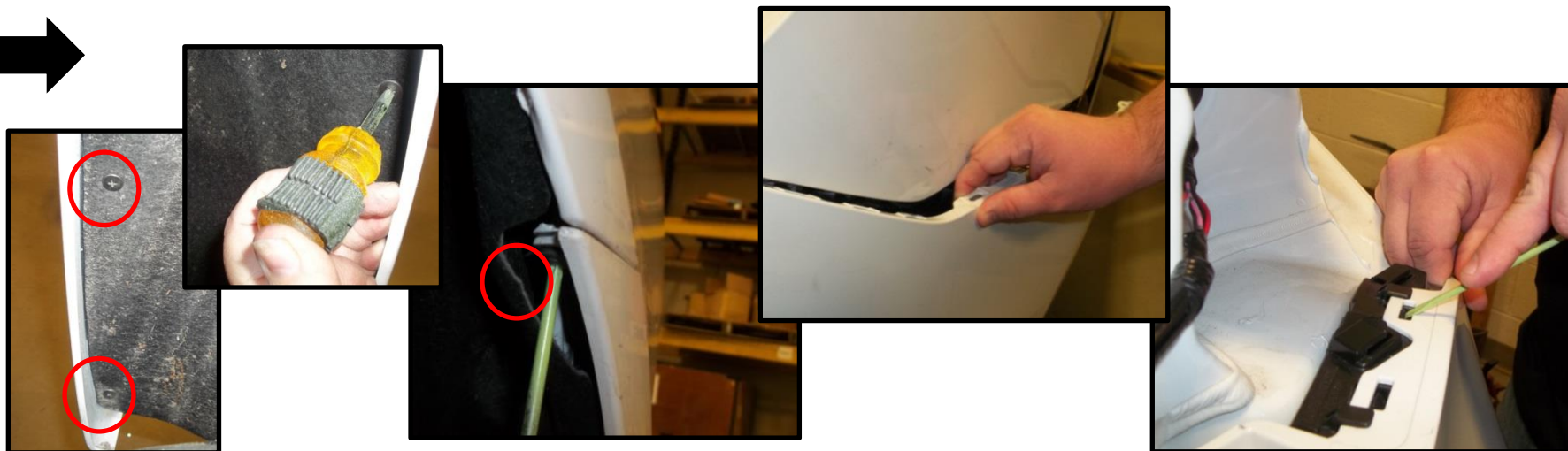

4. Remove bumper - remove bumper using 12mm socket (6) bolts. Carefully set the bumper aside. Using pliers bend bumper hanger support to approximately 90 degree for clearance.



5. Hitch installation – Hang the U-bolt on the tow hook. Raise the hitch and hang it on the bumper support on the end panel. Raise the bumper to sandwich the hitch, align the holes and reinstall the original bolts removed in step 4. Tighten to hold hitch in place. Install remaining fastener for the tow hook.

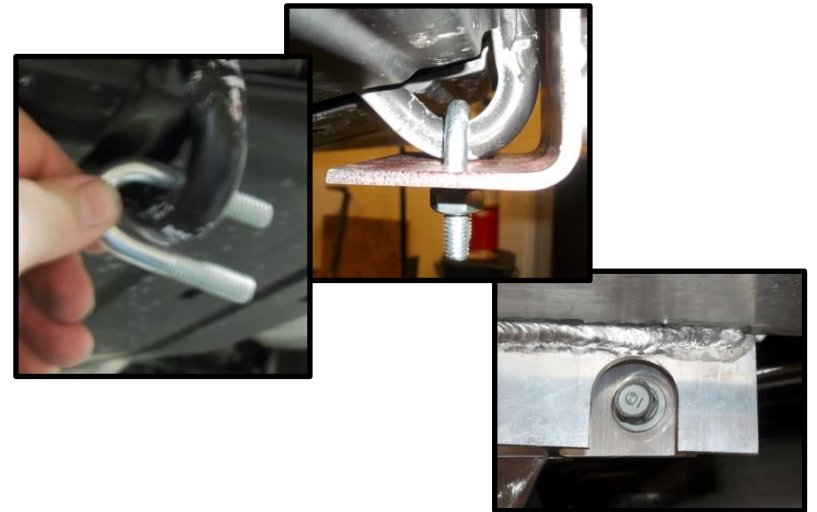

6. **Tighten all M8 CL8 fasteners with torque wrench to 20 Lb.-Ft. (27 N*M) and all 3/8 GR 5 fasteners with torque wrench to 30 Lb.-Ft. (41 N*M)**

⚠ Proper torque is needed to keep the hitch secure to the vehicle when towing.



7. Trim fascia- locate the center of bottom panel (tow hook) and trim 3-3/4" x 3-3/4" wide area, see Figure 3. Recommend radius in corners.

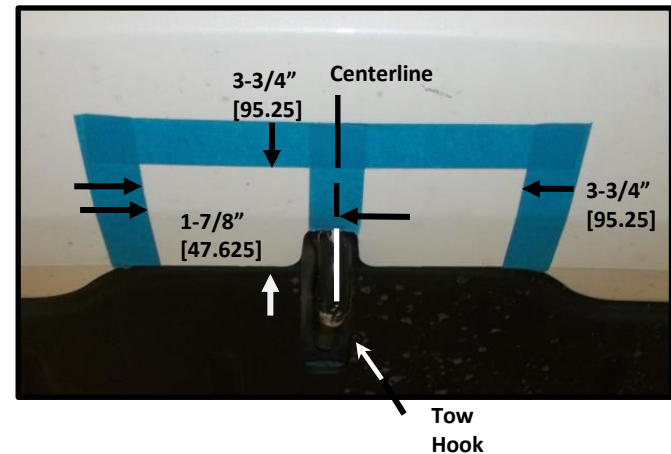

8. Re-install fascia - Reinstall all fasteners , fascia and tail light S removed in Step 1 - 3.



Instructions d'installation

NUMÉROS DE PIÈCES :24942, 77329, CQT24942



Numériser pour des conseils de sécurité, ou visitez <http://www.cequentgroup.com/qr-product.aspx>

⚠ WARNING

Pour prévenir les BLESSURES SÉVÈRES, FATALES ou les DOMMAGES

MATÉRIELS :

- **TOUJOURS lire, assimiler et observer les avertissements et les instructions relatives à l'attelage AVANT d'installer celui-ci. Conserver la documentation pour référence ultérieure.**
- **NE PAS découper, percer, souder ni modifier cet attelage-récepteur.**
- **S'ASSURER régulièrement que toute la visserie est correctement serrée et que l'attelage est monté sur le véhicule en toute sécurité.**
- **TOUJOURS lire, assimiler et observer tous les avertissements et toutes les instructions relatives au véhicule et aux autres accessoires utilisés avec l'attelage AVANT l'utilisation.**
- **PLACER les plus lourdes charges à l'avant de la remorque.**
- **NE PAS excéder les spécifications de charge du fabricant du véhicule, ni la moins élevée des valeurs suivantes :**

Type d'attelage	Poids brut max. de la remorque	Poids max. au timon
Sans répartition de charge	2000 lb. (908 kg)	200 lb. (90 kg)
Répartition de charge	X	X

- **TOUJOURS porter la ceinture de sécurité.**
- **RALENTIR lors du remorquage, ne JAMAIS dépasser la limite de vitesse signalée.**
- **En cas de BALANCEMENT EXCESSIF, retirer le pied de la pédale d'accélérateur et maintenir le volant aussi stable que possible. NE PAS appliquer les freins NI accélérer.**

GARANTIE À VIE LIMITÉE

1. **Garantie à vie limitée (« Garantie »).** Cequent Performance Products, Inc. (« Nous », « Notre ») garantit à l'acheteur initial seulement (« Vous », « Votre ») que le produit sera exempt de vices de matières et de fabrication, exception faite de l'usure normale. Cette garantie n'est valide que si : (a) les produits Nous sont retournés pour inspection et mise à l'essai; (b) Notre inspection révèle, à Notre satisfaction, que toute non conformité présumée est de nature matérielle et n'a pas été causée par une mauvaise utilisation, la négligence, l'usure, une installation, entreposage ou réparation incorrects, une modification ou un accident; (c) les produits ont été installés, entretenus et utilisés conformément à Nos instructions. LA GARANTIE SE SUBSTITUE À TOUTE AUTRE GARANTIE, EXPRESSE OU IMPLICITE (AUTRE QUE LA GARANTIE DE TITRE OFFERTE PAR LE CODE COMMERCIAL UNIFORME AU MICHIGAN), Y COMPRIS, MAIS SANS S'Y LIMITER, TOUTES LES GARANTIES RELATIVES À LA QUALITÉ MARCHANDE OU L'ADÉQUATION À UN USAGE PARTICULIER, CELLES-CI ÉTANT EXPRESSÉMENT REJETÉES.
2. **Obligations de l'acheteur.** Pour effectuer une réclamation, communiquez avec Nous à notre adresse principale du 47912 Halyard Drive, Suite 100, Plymouth, MI 48170, 1-800-632-3290; n'oubliez pas d'identifier le produit d'après le numéro de modèle et de suivre les directives qui vous seront fournies. Tout produit retourné qui est remplacé par Nous devient notre propriété. Vous serez tenu d'assumer les frais d'expédition de retour. Veuillez conserver votre reçu d'achat afin que nous puissions en vérifier la date et confirmer que Vous êtes l'acheteur initial. Le produit et le reçu d'achat doivent Nous être fournis afin que nous puissions traiter Votre réclamation.
3. **Recours exclusifs.** Le remplacement du produit est Votre seul recours en vertu de cette Garantie. Nous ne sommes pas responsables des frais de service ou de main-d'oeuvre encourus pour le retrait ou la réinstallation d'un produit. SOUS AUCUNE CIRCONSTANCE NOUS NE SERONS TENUS RESPONSABLES DES DOMMAGES INDIRECTS, PARTICULIERS, CONSÉCUTIFS OU PUNITIFS.
4. **Acceptation des risques.** Vous reconnaissez et acceptez que toute utilisation du produit à des fins autres que celle(s) stipulée(s) dans les instructions relatives au produit est faite à vos propres risques.
5. **Loi applicable.** Cette Garantie Vous confère des droits légaux spécifiques, et il se peut que Vous possédiez d'autres droits qui peuvent varier d'une province à l'autre. Cette Garantie est régie par les lois de l'État du Michigan, abstraction faite des règles relatives aux conflits de lois. Les cours de l'État situées dans le comté d'Oakland, Michigan, constituent les autorités judiciaires exclusives relativement à tout litige relevant de cette Garantie.

Rev 9/2014



Instructions d'installation

NUMÉROS DE PIÈCES : 24942, 77329, CQT24942

Applications :

Années	Marque	Modèles
2015-actuel* XXX		XX

2015-actuel* XXX

XX

*Visitez notre site Web pour obtenir de l'information à jour concernant une année et une version particulières.

Durée de l'installation : **Min.**

La valeur indiquée ci-dessus est la durée moyenne des installateurs professionnels. Si vous ressentez de l'inconfort à réaliser cette installation par vous-même ou si vous avez besoin d'assistance, veuillez communiquer avec un installateur professionnel.

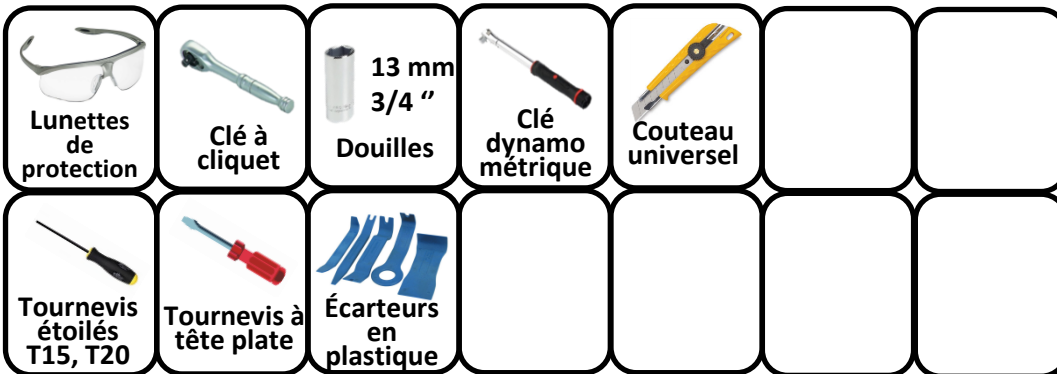

Photo représentative du véhicule



Avant du véhicule

Illustration de l'attelage

NE PAS EXCÉDER LES SPÉCIFICATIONS DE CHARGE DU FABRICANT DU VÉHICULE, NI LA MOINS ÉLEVÉE DES VALEURS SUIVANTES :

Type d'attelage	Poids brut max. de la remorque	Poids max. au timon
Sans répartition de charge	2000 lb. (908 kg)	200 lb. (90 kg)
Répartition de charge	X	X

⚠ Toujours porter des LUNETTES DE PROTECTION en installant l'attelage.



Numériser pour des instructions illustrées progressives sur l'installation, ou visiter <http://www.cequentgroup.com/gr-product.aspx>

Instructions d'installation

NUMÉROS DE PIÈCES :24942, 77329, CQT24942

(Se vende por separado)
Ensemble de barre de remorquage :
3593

La barre de remorquage doit être utilisée dans la position **ÉLEVÉE** seulement

der existant Longeron
Monture de pare-chocs
du chassis



(Rondelle conique)
Dents orientées contre l'attelage











Arrière

Figure 1

Figure 2

Visserie :

①	Qté (2)	Boulon de carrosserie ½-13 x 2.00 GR5 
②	Qté (2)	Espaceur .250 x 1 x 3 
③	Qté (2)	Rondelle conique ½" 
④	Qté (2)	Écrou hex. ½ -13 GR2 
⑤	Qté (4)	Boulon M8x1.25x40 CL8.8 
⑥	Qté (4)	Espaceur (trou rond) .250 x 1 x 1.5 
⑦	Qté (4)	Rondelle conique 3/8" 
⑧	Qté (2)	Fil à pêche ½-13 

Remarque : Visserie similaire des deux côtés

① ② ③ ④ ⑤ ⑥

1. X
2. X
3. Serrer toute la visserie M8 CL8.8 au couple de 20 lb-pi (27 N.m) et toute la visserie 1/2 GR5 au couple de 75 lb-pi (102 N.m).

⚠ Il est nécessaire de serrer la visserie en respectant les couples de serrage spécifiés pour bien fixer l'attelage sur le véhicule lors du remorquage.

Nota : Vérifier l'attelage fréquemment, en s'assurant que toutes les fixations et la boule sont serrées adéquatement. Si l'attelage est enlevé, boucher tous les trous percés dans le coffre ou la carrosserie afin de prévenir l'infiltration d'eau ou de gaz d'échappement. Un attelage ou une boule endommagés doivent être enlevés et remplacés. Observer les mesures de sécurité appropriées en travaillant sous le véhicule et porter des lunettes de protection. Ne jamais utiliser une torche pour découper un accès ou un trou de fixation. Ce produit est conforme aux normes V-5 et SAE J684 de la V.E.S.C. (État de New York) concernant les spécifications en matière de sécurité des systèmes d'attelage.

1a.

1b.



2.

3.

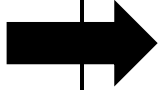



⚠ WARNING

Para evitar DAÑOS DE GRAVEDAD, A LA PROPIEDAD O LA MUERTE:

- **SIEMPRE** lea, entienda y siga las advertencias e instrucciones para su enganche **ANTES** de la instalación. Consérvelo para referencia futura.
- **NO** corte, suelde ni modifique este receptor.
- **VERIFIQUE** periódicamente que todos los fijadores estén apretados y que el enganche esté firmemente montado en su vehículo.
- **SIEMPRE** lea, entienda y siga todas las advertencias e instrucciones para su vehículo y para otros accesorios que va a utilizar con el enganche **ANTES** de usar.
- **CARGUE** el remolque más pesado por el frente.
- **NO** supere el valor inferior entre la calificación del fabricante del vehículo de remolque, o:

Tipo de enganche	Peso bruto máximo del remolque	Peso máximo de la horquilla
Carga de peso	2000 lb. (908 kg)	200 lb. (90 kg)
Distribución de peso	X	X

- Use **SIEMPRE** el cinturón de seguridad.
- **REDUZCA LA VELOCIDAD** al remolcar, **NUNCA** exceda ningún límite de velocidad.
- Si se produce **DEMASIADA OSCILACIÓN**, quite el pie del acelerador y sujete el volante lo más firme posible. **NO** aplique los frenos y **NO** aumente la velocidad.

GARANTÍA LIMITADA DE POR VIDA

1. **Garantía limitada de por vida ("Garantía")** Cequent Performance Products, Inc. ("nosotros", "nos" o "nuestro/a/s") garantiza al comprador original únicamente ("usted" o "su/s") que el producto estará libre de defectos significativos tanto en materiales como en mano de obra, con la excepción del desgaste normal. La garantía sólo es válida si (a) los productos se nos devuelven para inspección y pruebas; (b) Nuestra inspección revela a nuestra satisfacción que cualquier supuesta no conformidad es meritoria y no ha sido causada por el mal uso, negligencia, desgaste, instalación incorrecta, almacenamiento inadecuado, reparación inadecuada, alteración, o accidente; y (c) los productos fueron instalados, mantenidos y utilizados de acuerdo con nuestras instrucciones. **LA GARANTÍA REEMPLAZA CUALQUIER OTRA GARANTÍA, EXPRESA O IMPLÍCITA (EXCEPTO LA GARANTÍA DE TÍTULO SEGÚN LO ESTABLECE EL CODIGO COMERCIAL UNIFORME VIGENTE EN MICHIGAN), INCLUYENDO SIN LIMITACIÓN, LAS GARANTÍAS DE COMERCIALIZACIÓN O IDONEIDAD PARA UN PROPÓSITO PARTICULAR, TALES GARANTÍAS QUEDAN EXPRESAMENTE ANULADAS.**
2. **Obligaciones del comprador.** Para hacer una reclamación de garantía, contáctenos en nuestra dirección principal en 47912 Halyard Dr. Suite 100, Plymouth, MI 48170, 1-800-632-3290, identifique el producto por número de modelo y siga las instrucciones que se le darán para la reclamación. Cualquier producto devuelto que se reemplace o se reembolse se convierte en propiedad nuestra. Usted podría ser responsable por los costos de envío del producto. Conserve el recibo de compra para verificar la fecha de compra y que usted es el comprador original. Nos debe entregar el producto y el recibo de compra para procesar su reclamo de garantía.
3. **Recurso exclusivo.** El reemplazo del producto es su único y exclusivo recurso bajo esta Garantía. No seremos responsables por el servicio o cargos de mano de obra en los que se incurra al quitar o reemplazar un producto. **EN NINGÚN CASO SEREMOS RESPONSABLES DE LOS DAÑOS INDIRECTOS, ESPECIALES, CONSECUENCIALES O PUNITIVOS.**
4. **Riesgo asumido.** Usted reconoce y acepta que cualquier uso del producto para cualquier propósito diferente al uso(s) especificado(s) en las instrucciones del producto es a su propio riesgo.
5. **Ley gobernante.** Esta garantía le otorga derechos legales. Usted también podría tener otros derechos que varían de estado a estado. Esta garantía está regida por las leyes del estado de Michigan, sin importar las normas relativas a conflictos de ley. Las cortes estatales ubicadas en el condado de Oakland, Michigan tendrán la jurisdicción exclusiva para cualquier disputa que surja con respecto a esta garantía.

Rev 9/2014



Instrucciones de instalación

NÚMEROS DE PARTES: 24942, 77329, CQT24942

Aplicaciones:

Años	Marca	Modelos
------	-------	---------

2015-Actual*	X	X
--------------	---	---

*Visite nuestro sitio web para la información más actualizada respecto a los años de aplicación y los niveles de recorte.

Tiempo de instalación: **Min.**

El tiempo indicado anteriormente es el tiempo promedio para instaladores profesionales. Si usted no se siente cómodo para realizar esta instalación por su cuenta o necesita asistencia, sírvase ponerse en contacto con un instalador profesional.

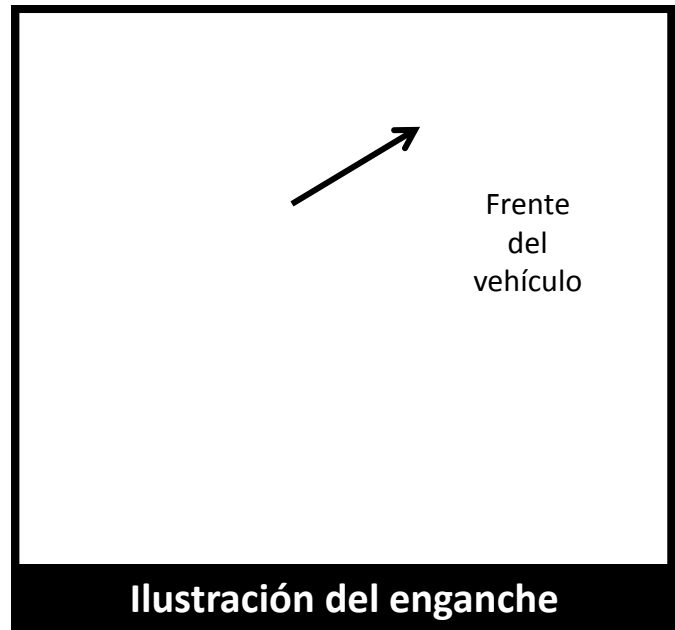

NO SUPERE LA CALIFICACIÓN INFERIOR DEL DEL FABRICANTE DEL VEHÍCULO DE REMOLQUE O:

Tipo de enganche	Peso bruto máximo del remolque	Peso máximo de la horquilla
Carga de peso	2000 lb. (908 kg)	200 lb. (90 kg)
Distribución de peso	X	X

Siempre use GAFAS DE SEGURIDAD al instalar el enganche

Instrucciones de instalación

NÚMEROS DE PARTES: 24942, 77329, CQT24942

(Vendu séparément)
Kit de barra de tracción:
 3593

La barra de tracción se debe usar en la posición **LEVANTADA** únicamente.



(Arandela cónica)
 Costado con dientes
 contra el enganche



Escanee para instrucciones de la instalación paso por paso con FOTO, o visite <http://www.cequentgroup.com/qr-product.aspx>



Atrás

Figura 1

Figura 2

Kit de tornillos:			
①	Cant. (2)	Perno de carruaje ½-13 x 2.00 GR5	
②	Cant. (2)	Espaciador .250 x 1 x3	
③	Cant. (2)	Arandela cónica ½"	
④	Cant. (2)	Tuerca hexagonal ½ -13 GR2	
⑤	Cant. (4)	Perno M8x1.25x40 CL8.8	
⑥	Cant. (4)	Espaciador (orificio redondo) .250 x 1 x1.5	
⑦	Cant. (4)	Arandela cónica 3/8"	
⑧	Cant. (2)	Alambre de insertar ½-13	

Figura 3

Nota: Tornillos iguales en ambos lados



1. X
2. Feed the coiled end of the pull wire through the bolt forward attachment hole in the side of the frame and out the access hole. Pull the pull wire with fasteners into location through the hole. Leave pull wires attached. Repeat the same process on the both frame rails.
3. Repeat the same process on the both frame rails.
4. Raise the hitch into position, feed the pull wires through the slots/holes on the brackets.
5. Raise hitch into position and install provided fasteners as shown. See Figure 2
6. Tighten all M14 CL10.9 fasteners with torque wrench to 100 Lb.-Ft. (136 N*M)

7. **Apretar todos los fijadores M8 CL8.8 con una llave de torsión a 20 Lb.-pies. (27 N*M) Apretar todos los fijadores de 1/2 GR5 con una llave de torsión a 75 Lb.-pies (102 N*M)**

⚠ Se necesita la torsión adecuada para mantener el enganche unido firmemente al vehículo durante el remolque.

Nota: Revise el enganche con frecuencia, verificando que todos los tornillos y la esfera estén correctamente apretados. Si se quita el enganche tape todos los orificios en el colector del baúl u otros paneles de la carrocería para evitar la entrada del agua y los gases del escape. Se debe retirar y reemplazar un enganche o esfera que se hayan dañado. Observe las precauciones de seguridad al trabajar por debajo del vehículo y use protección visual. No corte los orificios de acceso o accesorios con soplete.

Este producto cumple con las especificaciones y requisitos de seguridad para conectar dispositivos y sistemas de remolque del estado de Nueva York, V.E.S.C. Regulación V-5 y SAE J684.

1a.

1b.







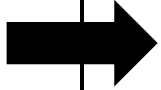





2.

3.



English**French****Spanish**

Carriage bolt 	Boulon de carrosserie	Perno de carruaje
Bolt M12 	Boulon M12	Perno M12
Spacer 	Espaceur	Espaciador
Spacer (round hole) 	Espaceur (trou rond)	Espaciador (orificio redondo)
Conical washer 	Rondelle conique	Arandela cónica
Lock washer 	Rondelle de blocage	Arandela de seguridad
Hex nut 	Écrou hex.	Tuerca hexagonal
Pull wire ½-13 	Fil à pêche	Alambre de insertar
Bevel washer 	Rondelle en biseau	Arandela biselada
Cable tie 	Attache de câble	Amarres de cables
Frame rail	Longeron	Larguero del bastidor
Access hole	Trou d'accès	Orificio de acceso
Bumper beam	Poutre de pare-chocs	Travesaño del parachoques
Vehicle end panel	Panneau d'extrémité du véhicule	Panel lateral del vehículo
Weldnut	écrou soudé	tuerca de soldar
Spare tire	Pneu de secours	llanta de repuesto
Flat washer 		

⑦ ⑧ ⑨ ⑩ ⑪ ⑫

