

16K

Signature Series

INSTALLATION INSTRUCTIONS MOUNTING KIT DODGE '02-CURRENT 1500, '03-CURRENT 2500/3500 INCLUDES HD / 6' & 8' BEDS

18K

Signature Series

DEALER/INSTALLER:

- (1) Provide this Manual to end user.

END USER:

- (1) Save this Manual for future reference.
- (2) Pass on copies of Manual to any other user or owner of Hitch.

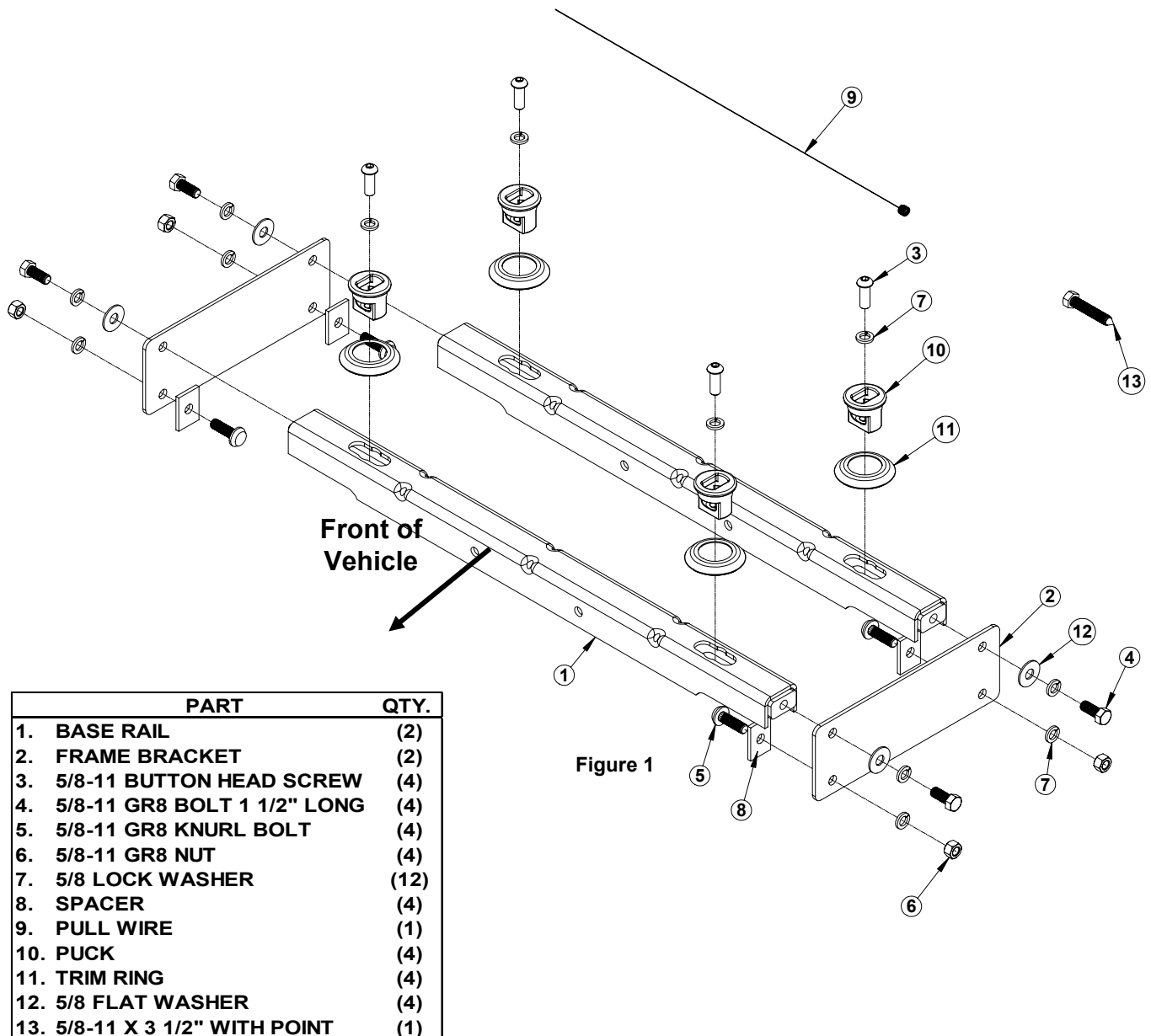

For Installation Assistance or Technical Help, Call 1-800-758-0869

⚠ WARNING:

Failure to follow all of these instructions may result in death or serious injury!

INDEX

- | | |
|--|--------|
| 1. GUIDELINES FOR MATCHING TOW VEHICLE AND TRAILER | P. 2-4 |
| 2. ASSEMBLY INSTRUCTIONS | P. 5-8 |
| 3. CEQUENT TOWING PRODUCTS SEVEN YEAR LIMITED WARRANTY | P. 9 |

GUIDELINES FOR MATCHING HITCH TRUCK AND TRAILER

⚠ WARNING:

Failure to check and follow tow ratings could result in tow vehicle damage or truck and trailer separation while towing.

- Trailer and its contents together must not exceed truck, hitch and/or trailer tow ratings.
- Towing vehicle must have a manufacturer's rated towing capacity equal to or greater than the gross trailer weight (dry weight of the trailer plus payload of the trailer). (Figure 2)
- Gross weight of trailer must not exceed fifth wheel hitch rating.
- King pin weight must not exceed fifth wheel rating (Figure 3). If in doubt have king pin weight measured by a qualified technician.

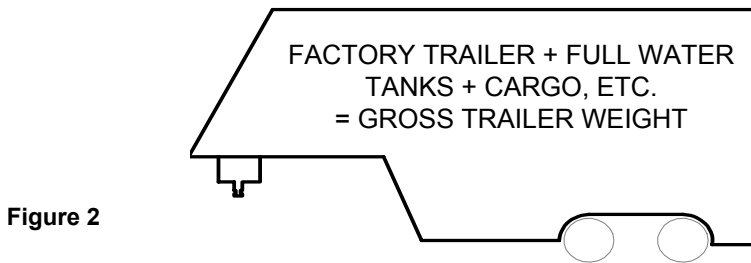

Figure 2

1. Check Tow Ratings:
Vehicle Tow Rating: _____
Signature Series Hitch Rating: _____
Gross Trailer Weight (Figure 2): _____
***Trailer weight should be the lowest of these recorded ratings for safe towing conditions.**
2. **Cequent Towing Products** hitches are designed for use with recreational fifth wheel trailers only. Hitch applications other than recreational fifth wheel trailers must be approved in writing by **Cequent Towing Products'** Engineering Department.
3. Use only a SAE 2-inch kingpin with your *Signature Series* Fifth Wheel Hitch.
4. Approximately 15%-25% of trailer weight should be on hitch (Pin Weight)(Figure 3).

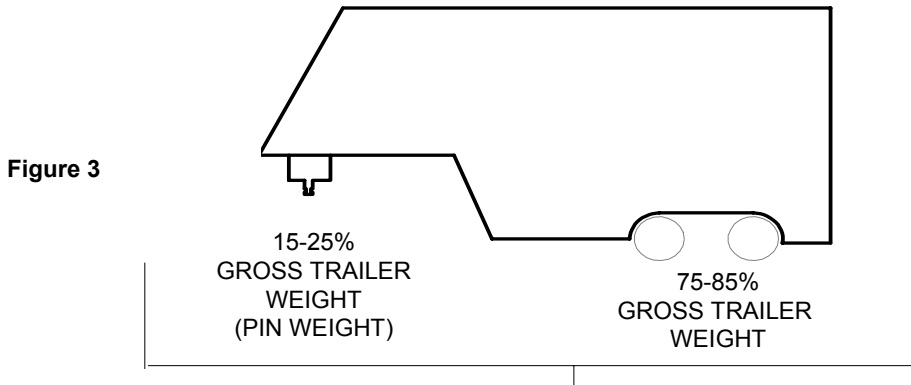
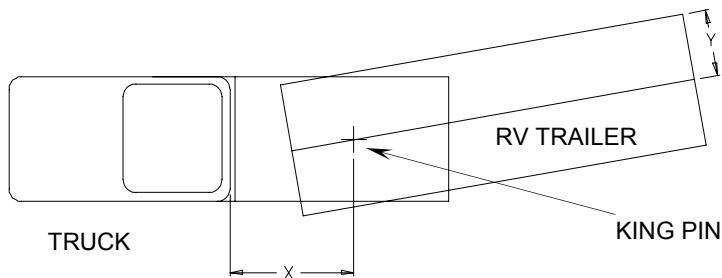

Figure 3

5. Trucks come in many different configurations. **Cequent Towing Products'** hitches are designed for use in light trucks such as the Ford F-Series, the Chevy Silverado and the Dodge Ram. **Cequent Towing Products** recommends the use of long bed (8ft) light trucks for the best combination in truck - trailer turning clearance.

Rule of thumb: The distance from the back of the truck cab to the center of the rear truck axle ("X" in **Figure 4**), should be approximately 4 inches greater than one-half the trailer width ("Y" in **Figure 4**).

Figure 4



6. If a short bed pickup (less than 8 ft. but longer than 6 ft.) is to be used for towing, **Cequent Towing Products** recommends the trailer be equipped with an extended pin box to help gain additional truck - trailer turning clearance (See trailer manufacturer for options) (**Figure 5**). It also may be helpful to add a *Signature Series* Slider (**Part # 30070**) for increased turning clearance for low speed, non-highway maneuvering.

Figure 5

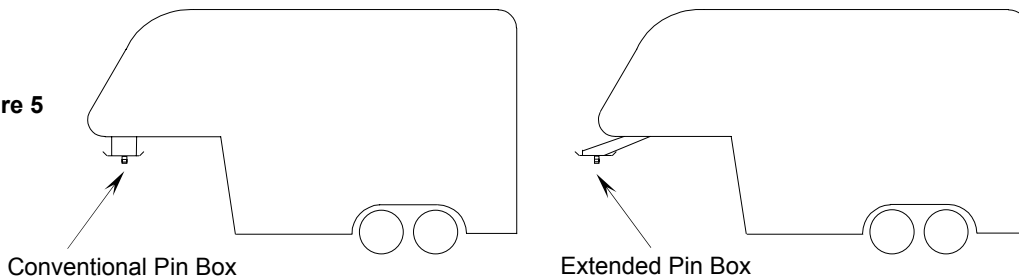

⚠ WARNING:
Do Not install this fifth wheel hitch on or attempt to tow with a short bed pickup truck that has a bed shorter than 6 ft.!

7. The height of the hitch and the pin box should be adjusted so the trailer is approximately level as it is towed. Allow approximately 6 inches clearance between the top of the pickup walls and the underside of the front of the trailer for pitch and roll of the trailer. (**Figure 6**). Allow more clearance between pickup walls and trailer for off road use.

Figure 6

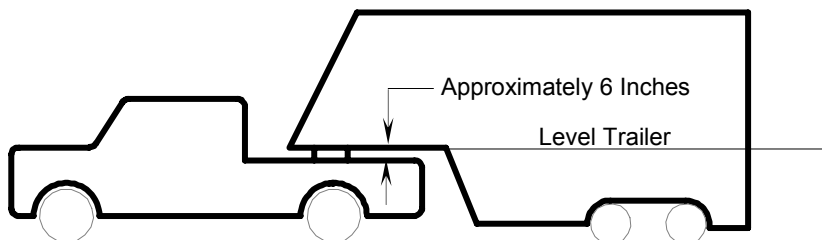

CAUTION:

The measurements above are guidelines. If your measurements are close to these numbers re-check clearances. If vehicle and/or trailer has any added bed vicinity accessories (i.e. fairings, air dams, ground effects, bed rails, etc.). Additional dimensioning and clearance checks have to be made.

8. Hitch height determination:

With trailer leveled and on level ground measure from the ground to the king pin box ("A" in **Figure 7**). Secondly measure from the height of the inside of the truck bed ("B" in **Figure 7**). Determine the amount of clearance over the side rails ("C" and "D" in **Figure 7**), as mentioned in **Note 7**.

$$\text{Hitch Height} = A - B + 2''$$

The 2" value is an estimate of suspension compression due to king pin weight of the trailer. This compression could range between 1"-5" depending on the truck being used and the trailer being towed.

$$D - C + 2'' > 6'' \text{ as in Note 7.}$$

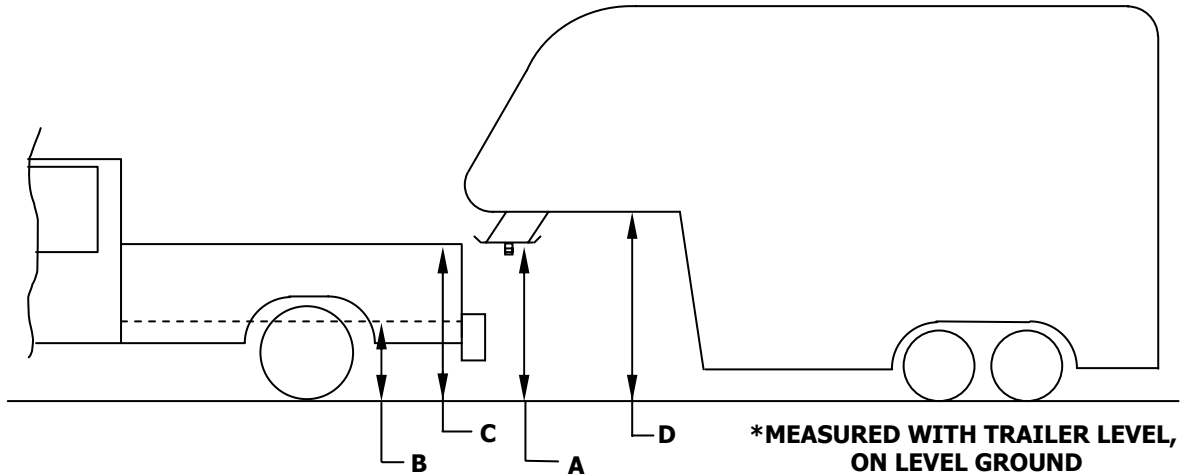

Figure 7

9. If a lube plate is to be used with a *Signature Series* 5th Wheel it must be at least 12" in diameter. **Cequent Towing Products** offers this optional lube plate as part # 83001 / 40001.

⚠ WARNING:

- Connection for trailer wiring must be located at the side of the truck bed between the driver's seat and the rear wheel to prevent operators from working between the truck and trailer.
- Avoid putting any part of your body under the trailer or between the truck and trailer. Unexpected or accidental movement of the truck or the trailer can cause serious injury or death
- If you must place any part of your body under the trailer or between the truck and trailer you **MUST** perform **ALL** of the following steps:
 - Check that the truck transmission is in park
 - Check that the emergency brake is on
 - Block in front of and behind all trailer tires
 - Check that the trailer landing gear are resting on firm ground

GENERAL INSTRUCTIONS FOR FIFTH WHEEL INSTALLATION

TOOLS

- | | |
|-----------------|---|
| 3/16" Drill | 15/16" Socket & Open End Wrench |
| 21/32" Drill | 200 lb-ft Torque Wrench |
| 3/8" Hex socket | 2-1/2" Hole Saw OR 2 1/2" Greenlee Knockout Punch |

CAUTION!

Read page 2-4 of these instructions before starting installation. Failure to do so could result in significant vehicle damage!

1. The following instructions should be used to mount the 5th wheel. Care and attention to detail will ensure a quick quality installation. Check parts against parts list to become familiar with parts in kit. (**Figure 1**)
2. Raise rear of truck high enough to allow jack stands to be placed under rear spring hanger bracket of truck. This will provide maximum room to install the 5th wheel brackets.



WARNING:

If the truck is raised, be sure that the truck is properly blocked and restrained to prevent the truck from falling. Failure to do so may result in the truck suddenly falling, causing death or serious injury.

3. Plastic drop-in bed liners must be cut out of the way. **Remove plastic bed liner if applicable.** Spray-in bed liners and bed mats less than 1/4" thick will work with normal installation instructions. **Note:** Consult installer for recommended curing time on spray-in liner before cutting holes through bed.

CAUTION:

Check for obstructions before drilling. Failure to do so could result in damaged fuel or brake lines, structural members, etc. **CEQUENT TOWING PRODUCTS** does its best to communicate tow vehicle manufacturer changes; however, it is ultimately the responsibility of the installer to prevent damage due to installation.

4. Use only **CEQUENT TOWING PRODUCTS** supplied bolts, nuts, and washers to install this kit. All bolts and nuts are grade 8 unless specified otherwise.
5. These instructions are intended for a specific group of trucks. If these instructions do not apply to your vehicle, contact Technical Service to get proper instructions. Each frame bracket must be bolted to the vehicle frame with two bolts.

CAUTION:

These instructions are guidelines only. Actual installation is the responsibility of the installer and the owner. Always measure truck and trailer before installing hitch to be sure that there is clearance at the cab and at the bumper to allow for turns.

6. Insert rails as shown in the following steps (**Figures 8 through 13**). With flat side up insert rear rail first rail followed by the front rail with flat side up.

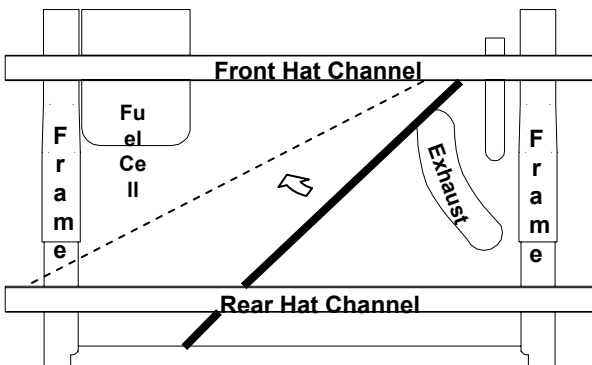
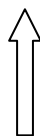

Figure 8



Forward

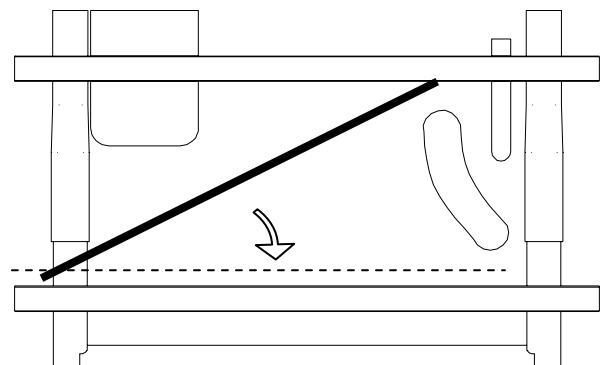

Figure 9

Step 1 : Slide the rear rail in at an angle over the axle and in front of the exhaust. Lift and rotate it so that it rests on the frame (drivers side)

Step 2 : Continue rotating the rail up and over the exhaust so that it is against the rear hat channel

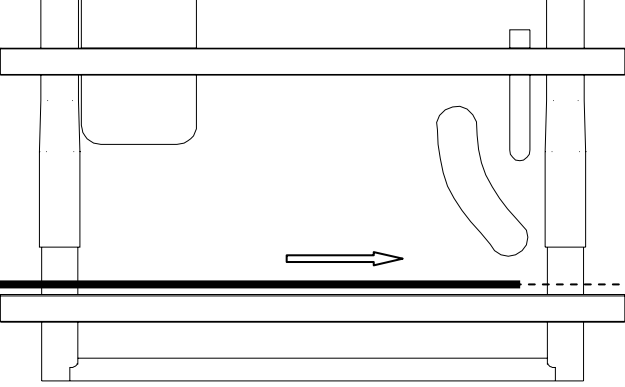

Figure 10

Step 3 : Slide the rail across so that it extends over the frame on the passenger side and does not rest on the frame on the drivers side

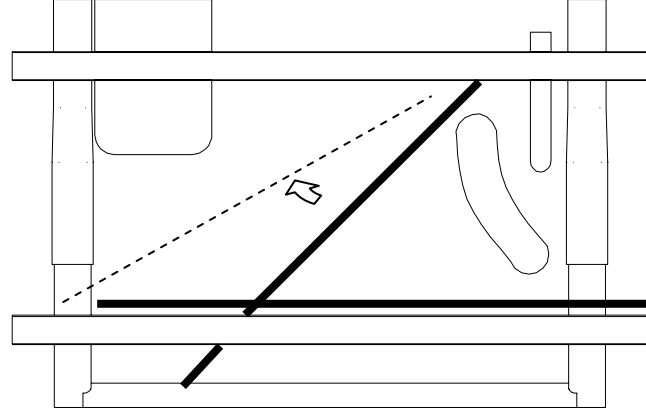

Figure 11

Step 4 : Insert the front rail in the same manner as the rear rail so that it rests on the frame (drivers side)

↑
Forward

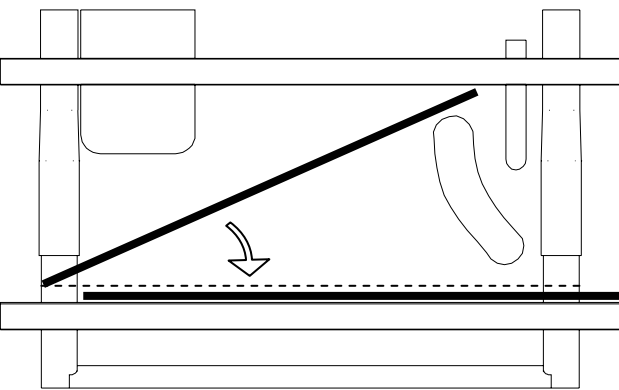

Figure 12

Step 5 : Rotate the rail up and over the exhaust so that it is against the rear rail

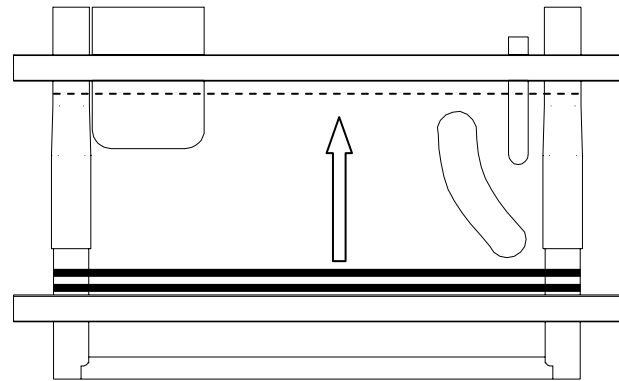
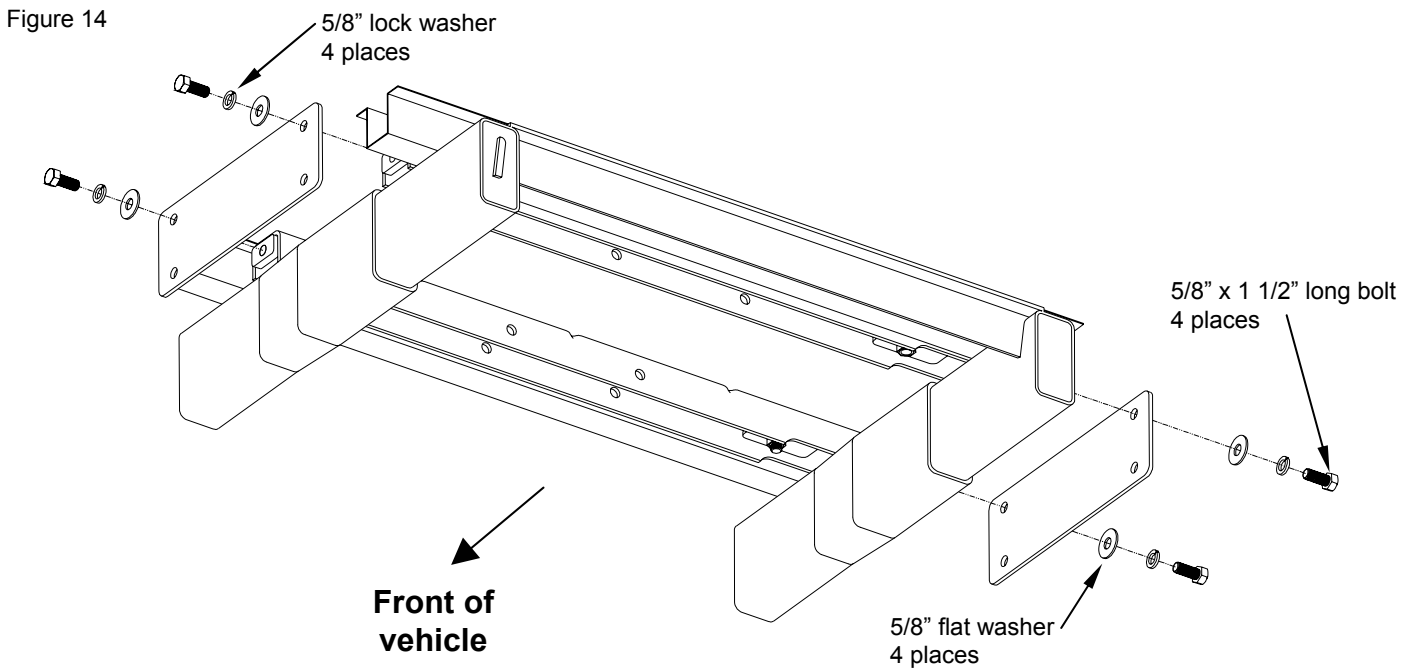

Figure 13

Step 6 : Slide the front rail forward with both ends resting on the frame. Slide the rear rail to the left so that it rests evenly on both sides of the frame

7. Loosely attach frame brackets to rails using 5/8" X 1 1/2" long bolts, flat washer & lock washers. (Figure 14)



CAUTION:

Check for obstructions before drilling. Failure to do so could result in damaged fuel or brake lines, structural members, etc. **CEQUENT TOWING PRODUCTS** does its best to communicate tow vehicle manufacturer changes; however, it is ultimately the responsibility of the installer to prevent damage due to installation.

- 8. Slide rail assembly as far rearward as possible then using frame bracket as template, and after checking rails are square with each other, drill pilot holes in frame. Enlarge pilot holes to 21/32" diameter holes (**Figure 15**).
Optional: Spray under coating around drilled holes to prevent rusting.

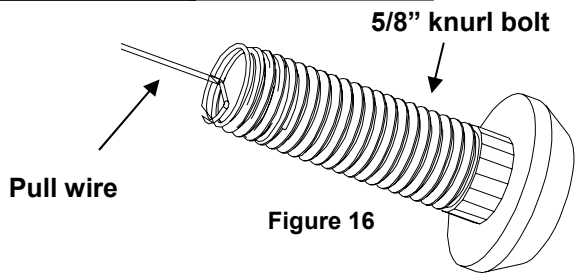
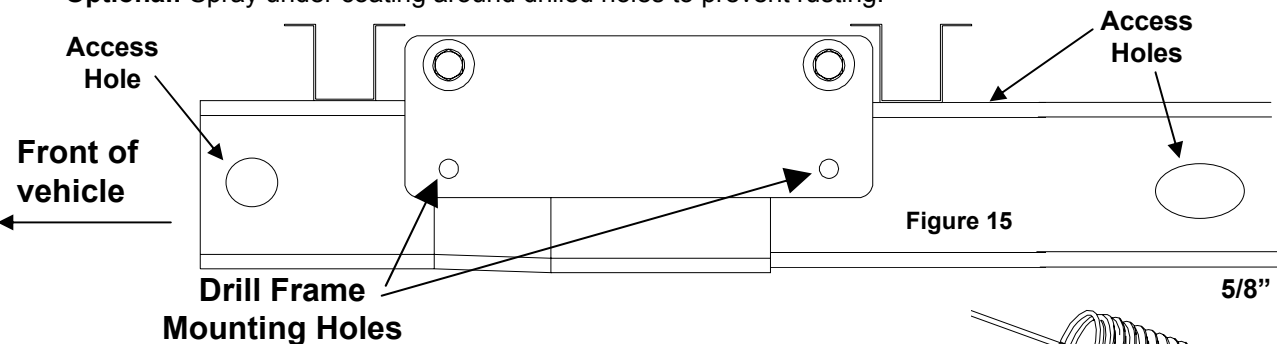

CAUTION:

It is important that 21/32" drill be used for holes in chassis frame as knurl bolts may break if too small a hole is used and neck may not grip if too large a hole is used.

- 9. Thread 5/8" x 2" knurl bolt onto pull wire (**Figure 16**). Insert straight end of pull wire into access hole and guide wire through drilled mounting holes. Pull wire out through mounting hole to position rib neck bolt for connecting rail bracket and chassis rail (**Figure 17**). Repeat process for all four knurl bolt locations.
- 10. Loosely attach frame brackets to frame using 5/8" x 2" rib neck bolts, spacers, lock washers, and nuts; fasten until hand tight (**Figure 17**).

Figure 17

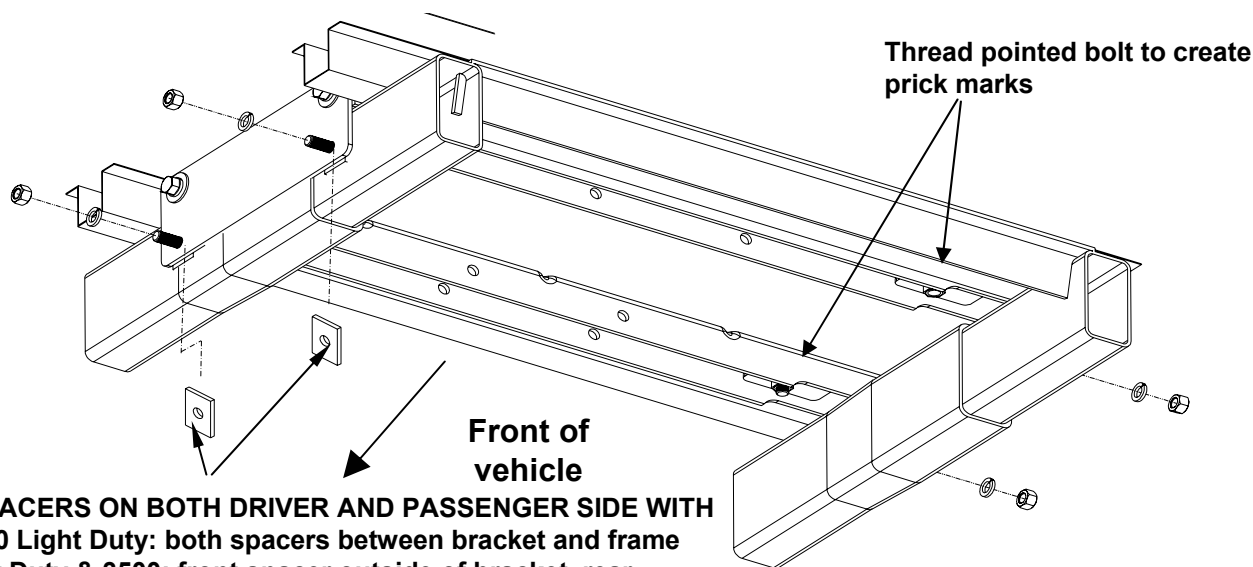

INSERT SPACERS ON BOTH DRIVER AND PASSENGER SIDE WITH
1500 & 2500 Light Duty: both spacers between bracket and frame
2500 Heavy Duty & 3500: front spacer outside of bracket, rear spacer between bracket and frame

- 11. Using pointed bolt (**Figure 18**), screw pointed bolt in to the nuts that are welded to the rail assembly until a prick mark is visible in the truck bed (**Figure 17**). Access to the fourth welded nut is obstructed by chassis components; the fourth prick mark must be measured from the other three prick marks (**Figure 19**). If you have a plastic bed liner cut 19" X 4" slots in plastic drop-in bed liner measured from prick marks in truck bed. If the *Signature Series* slider fifth wheel assembly is used, then see fifth wheel slider assembly instructions for slot cut dimensions.

Figure 18



Figure 19

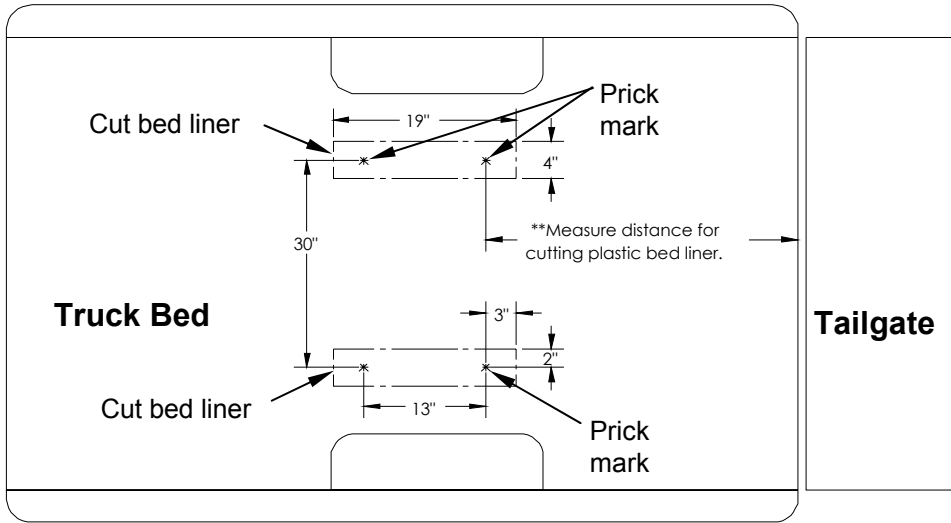

12. Remove 5/8" x 1 1/2" bolts attaching frame bracket to mounting rails. Move rails rearward or forward to prevent interference with hole drilling or punching of the truck bed.

CAUTION:

Check for obstructions before drilling. Failure to do so could result in damaged fuel or brake lines, structural members, etc. **CEQUENT TOWING PRODUCTS** does its best to communicate tow vehicle manufacturer changes; however, it is ultimately the responsibility of the installer to prevent damage due to installation.

13. Drill pilot holes in truck bed at prick mark locations. With hole saw or knockout punch create 2 1/2" hole centered at pilot holes. **Note:** Consult installer for recommended curing time on spray-in liner before cutting holes through bed. **Optional:** Spray under coating around 2 1/2" holes to prevent rusting.
14. Loosely reattach rails to frame bracket.
15. From truck bed attach pucks and trim rings to rails (**Figure 20**) using 5/8" button head screw and lock washer. Tighten to 100ft.lbs. torque.

⚠ WARNING:
DO NOT lubricate threads. It may cause bolt failure.

Figure 20

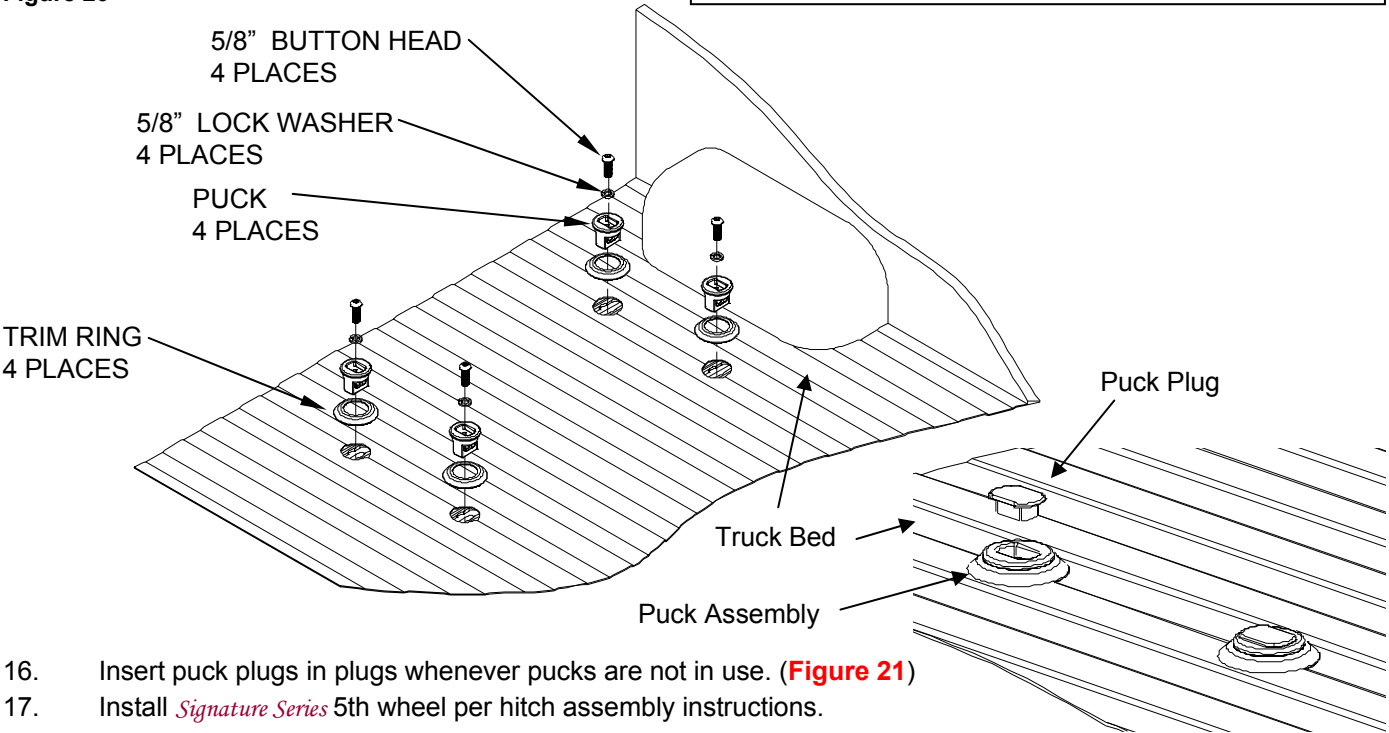

16. Insert puck plugs in plugs whenever pucks are not in use. (**Figure 21**)
17. Install *Signature Series* 5th wheel per hitch assembly instructions.
18. Torque hitch assembly bolts per hitch instructions.
19. Torque all 5/8" rail kit hex bolts to 170ft.lbs
20. Replace any brake lines and spare tire that may have been removed/relocated.

Figure 21

NOTES

SEVEN YEAR LIMITED WARRANTY

Hitches - Custom Receivers

Cequent Towing Products warrants the *Signature Series* 5th Wheel Hitch Mounting Kits from date of purchase against defects in material and workmanship under normal use and service, ordinary wear and tear excepted, for 7 years of ownership to the original consumer purchaser when a Cequent Towing Products *Signature Series* 5th Wheel Hitch is used.

Cequent Towing Products will replace FREE OF CHARGE any part which proves defective in material or workmanship when presented to any Cequent Towing Products dealer, Cequent Towing Products Warehouse or returned to factory. TRANSPORTATION CHARGES PREPAID, at the address below. THIS WARRANTY IS LIMITED TO DEFECTIVE PARTS REPLACEMENT ONLY. LABOR CHARGES AND/OR DAMAGE INCURRED IN INSTALLATION OR REPLACEMENT AS WELL AS INCIDENTAL AND CONSEQUENTIAL DAMAGES CONNECTED THEREWITH ARE EXCLUDED.

Some states do not allow the exclusion or limitation of incidental or consequential damages, so the above limitation or exclusion may not apply to you.

Any damage to the *Signature Series* 5th Wheel Hitch as a result of misuse, abuse, neglect, accident, improper installation, or any use violative of instructions furnished by us, WILL VOID THE WARRANTY.

This warranty gives you specific legal rights, and you may also have other rights which vary from state to state. In the event of a problem with warranty service or performance, you may be able to go to a small claims court, or a federal district court.

Cequent Towing Products, Inc.
2602 College Avenue
Goshen, IN 46528