

Installation Instructions

READ THOROUGHLY BEFORE BEGINNING

Part Numbers:

Signature Series Rail Kit

30074

Dodge Ram Trucks-all, including Mega-cabs

⚠ WARNING:

Failure to follow all of these instructions may result in death or serious injury!

INDEX

- | | |
|--|--------------|
| 1. GUIDELINES FOR MATCHING TOW VEHICLE AND TRAILER. | Pages 1 - 3 |
| 2. DRILLED AND BOLTED INSTALLATION FIGURE. | Page 4 |
| 3. NO-DRILL, CLAMPED ON INSTALLATION FIGURE. | Page 5 |
| 4. ASSEMBLY INSTRUCTIONS. | Pages 6 - 10 |
| 5. CEQUENT TOWING PRODUCTS <u>SEVEN YEAR LIMITED WARRANTY.</u> | Page 11 |

GUIDELINES FOR MATCHING TOW VEHICLE AND TRAILER

⚠ WARNING:

Failure to check and follow tow ratings could result in tow vehicle damage or truck and trailer separation while towing.

- Trailer and its contents together must not exceed truck, hitch and/or trailer tow ratings.
- Towing vehicle must have a manufacturer's rated towing capacity equal to or greater than the gross trailer weight (dry weight of the trailer plus payload of the trailer). Figure1.
- Gross weight of trailer must not exceed fifth wheel hitch rating.
- King pin weight must not exceed fifth wheel rating, Figure 2. If in doubt have king pin weight measured by a qualified technician.

Figure1.

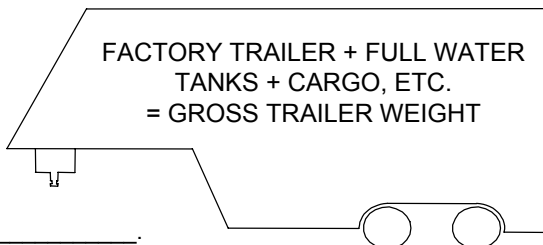

1. Check Tow Ratings:
Vehicle Tow Rating: _____
Signature Series Hitch Rating: _____
Gross Trailer Weight **Figure 1**: _____
***Trailer weight should be the lowest of these recorded ratings for safe towing conditions.**
2. **Cequent Towing Products** hitches are designed for use with recreational fifth wheel trailers only. Hitch applications other than recreational fifth wheel trailers must be approved in writing by **Cequent Towing Products** Engineering Department.
3. Use only a SAE 2-inch kingpin with your *Signature Series* Fifth Wheel Hitch.
4. Approximately 15%-25% of trailer weight should be on hitch (Pin Weight), **Figure2.**

Figure 2.

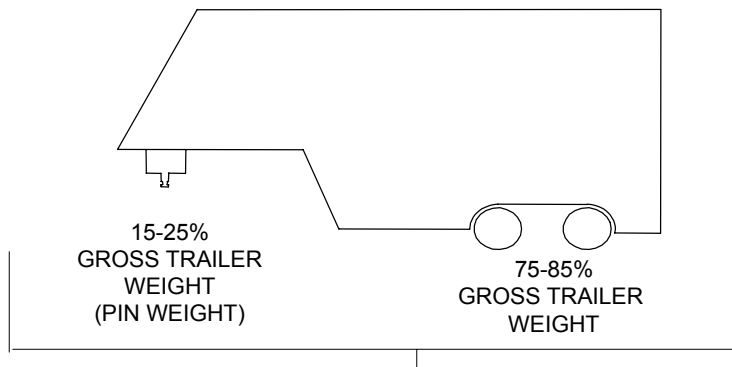

Installation Instructions

READ THOROUGHLY BEFORE BEGINNING

Part Numbers:

Signature Series Rail Kit

30074

Dodge Ram Trucks-all, including Mega-cabs

5. Trucks come in many different configurations. **Cequent Towing Products** hitches are designed for use in light trucks such as the Ford F-Series, the Chevy Silverado and the Dodge Ram. **Cequent Towing Products** recommends the use of long bed (8ft) light trucks for the best combination in truck - trailer turning clearance.

Rule of thumb: The distance from the back of the truck cab to the center of the rear truck axle ("X" in **Figure 3**), should be approximately 4 inches greater than one-half the trailer width ("Y" in **Figure 3**).

Figure 3.

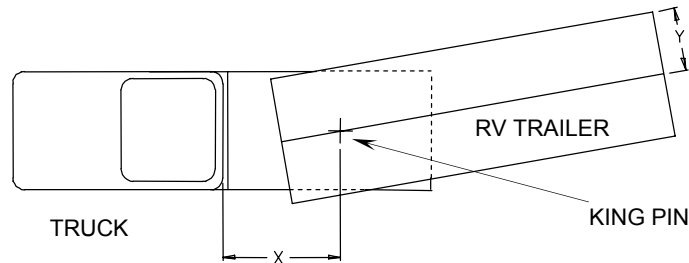

6. If a short bed pickup (less than 8 ft. but longer than 6 ft.) is to be used for towing, **Cequent Towing Products** recommends the trailer be equipped with an extended pin box to help gain additional truck - trailer turning clearance (See trailer manufacturer for options), **Figure 4**. It also may be helpful to add a *Signature Series* Slider (**Part # 30070**) for increased turning clearance for low speed, non-highway maneuvering.

Figure 4.

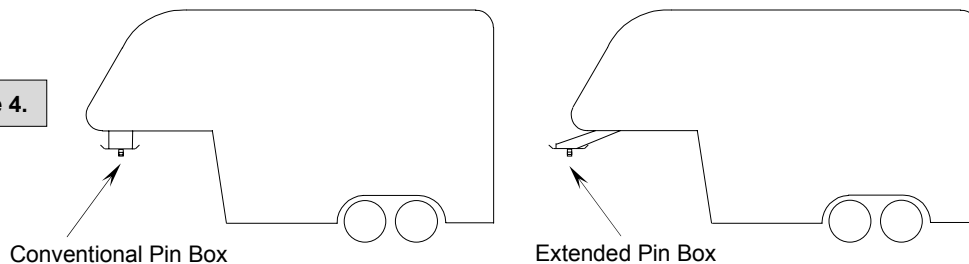

⚠ WARNING:

Do Not install this fifth wheel hitch on or attempt to tow with a short bed pickup truck that has a bed shorter than 6 ft.!

7. The height of the hitch and the pin box should be adjusted so the trailer is approximately level as it is towed. Allow approximately 6 inches clearance between the top of the pickup walls and the underside of the front of the trailer for pitch and roll of the trailer, **Figure 5**. Allow more clearance between pickup walls and trailer for off road use.

Figure 5.

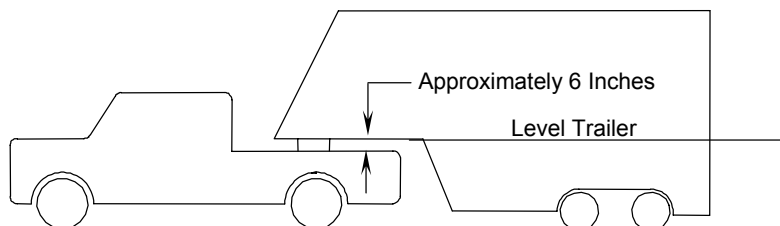

CAUTION:

The measurements above are guidelines. If your measurements are close to these numbers re-check clearances. If vehicle and/or trailer has any added bed vicinity accessories (i.e. fairings, air dams, ground effects, bed rails, etc.). Additional dimensioning and clearance checks have to be made.

Installation Instructions

READ THOROUGHLY BEFORE BEGINNING

Part Numbers:

Signature Series Rail Kit

30074

Dodge Ram Trucks-all, including Mega-cabs

8. Hitch height determination:

With trailer leveled and on level ground measure from the ground to the king pin box ("A" in **Figure 6**). Secondly measure from the height of the inside of the truck bed ("B" in **Figure 6**). Determine the amount of clearance over the side rails ("C" and "D" in **Figure 6**), as mentioned in **Note 7**.

$$\text{Hitch Height} = A - B + 2''$$

The 2" value is an estimate of suspension compression due to king pin weight of the trailer. This compression could range between 1"-5" depending on the truck being used and the trailer being towed.

$$D - C + 2'' > 6'' \text{ as in Note 7.}$$

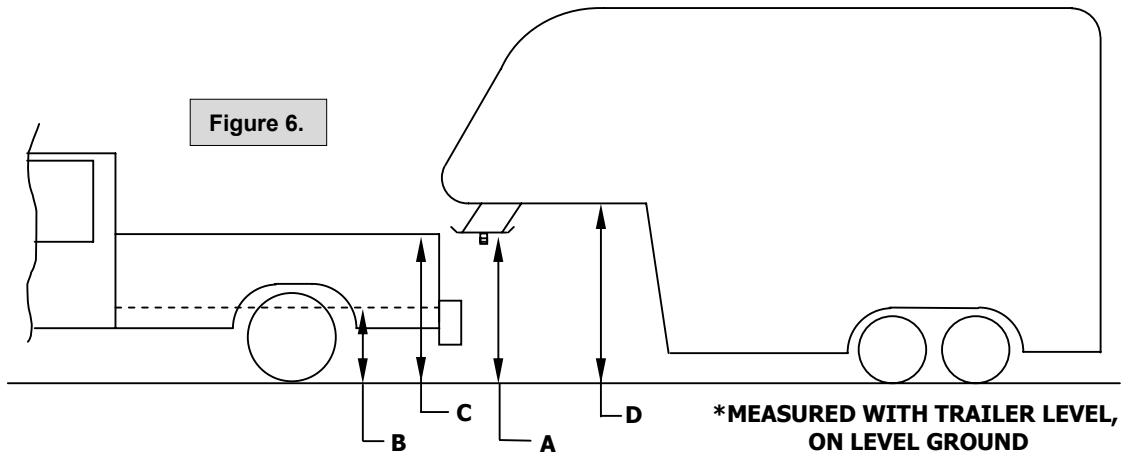

9. If a lube plate is to be used with a *Signature Series* 5th Wheel it must be at least 12" in diameter. **Cequent Towing Products** offers this optional lube plate as part # 83001 / 40001.

⚠ WARNING:

- Connection for trailer wiring must be located at the side of the truck bed between the driver's seat and the rear wheel to prevent operators from working between the truck and trailer.
- Avoid putting any part of your body under the trailer or between the truck and trailer. Unexpected or accidental movement of the truck or the trailer can cause serious injury or death
- If you must place any part of your body under the trailer or between the truck and trailer you **MUST** perform **ALL** of the following steps:
 - Check that the truck transmission is in park
 - Check that the emergency brake is on
 - Block in front of and behind all trailer tires
 - Check that the trailer landing gear are resting on firm ground

Installation Instructions

READ THOROUGHLY BEFORE BEGINNING

Part Numbers:

30074

Signature Series Rail Kit

Dodge Ram Trucks-all, including Mega-cabs

Equipment Required:

Fastener Kit: 30074F

Sockets & Wrenches: 3/8" Hex Socket, 3/4", 7/8", 15/16"

Drill Bits: 3/16", 21/32", 2-1/2" Hole Saw or Knockout Punch.

Other Tools: Measuring tape, Sheet metal cutters, Files (round & flat), Hammer, Center punch, Torque wrench, Hand drill, Various socket extensions & adaptors,

WARNING: This hitch is designed to safely carry the loads specified. Under no circumstances do we recommend exceeding the towing vehicle manufacturers recommended vehicle towing capacity.

All hitch fasteners & brackets typical both sides of vehicle.

NOTE! This hitch can be installed either by clamping-on or bolting-on. **Figure 7.** below shows how to drill and bolt-on. **Figure 8.** on next page shows how to clamp-on.

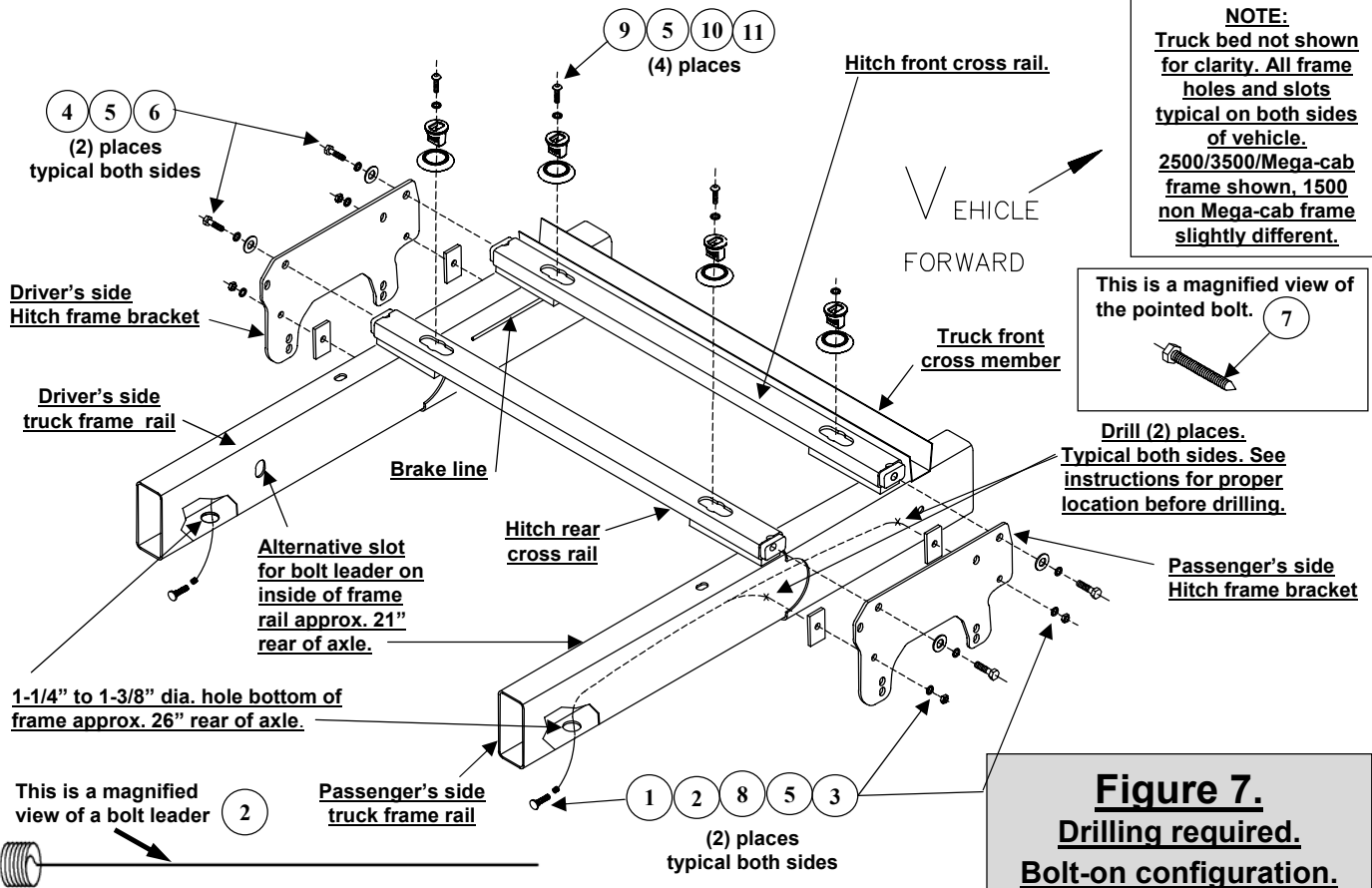

1	Qty. (4)	5/8-11 X 1-1/2" GR.8 Ribbed neck bolt	9	Qty. (4)	5/8"-11 Button head screw
2	Qty.(2)	5/8" Bolt leader – 32"	10	Qty. (4)	Puck
3	Qty. (4)	5/8"-11 Hex nut	11	Qty. (4)	Trim ring
4	Qty. (4)	5/8-11 X 1-1/2" Gr. 8 Hex bolt.			
5	Qty. (12)	5/8" Lock washer			
6	Qty. (4)	5/8" Flat washer			
7	Qty. (1)	5/8"-11 X 3-1/2" bolt, pointed			
8	Qty. (4)	1/4" X 1-1/2" X 2" Block, Hole in center, use as needed.			

Installation Instructions

READ THOROUGHLY BEFORE BEGINNING

Part Numbers:

30074

Signature Series Rail Kit Dodge Ram Trucks-all, including Mega-cabs

Equipment Required:

Fastener Kit: 30074F

Sockets & Wrenches: 3/8" Hex Socket, 3/4", 7/8", 15/16"

Drill Bits: 3/16", 21/32", 2-1/2" Hole Saw or Knockout Punch.

Other Tools: Measuring tape, Sheet metal cutters, Files (round & flat), Hammer, Center punch, Torque wrench, Hand drill, Various socket extensions & adaptors.



WARNING: This hitch is designed to safely carry the loads specified. Under no circumstances do we recommend exceeding the towing vehicle manufacturers recommended vehicle towing capacity.

NOTE! This hitch can be installed either by clamping-on or bolting-on. Figure 7, previous page shows how to drill and bolt on. Figure 8, below shows how to clamp on.

All hitch fasteners & brackets typical both sides of vehicle, except #8

NOTE:
Truck bed not shown for clarity. All frame holes and slots typical on both sides of vehicle.
2500/3500/Mega-cab frame shown, 1500 non Mega-cab frame slightly different.

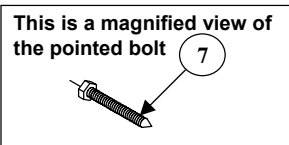
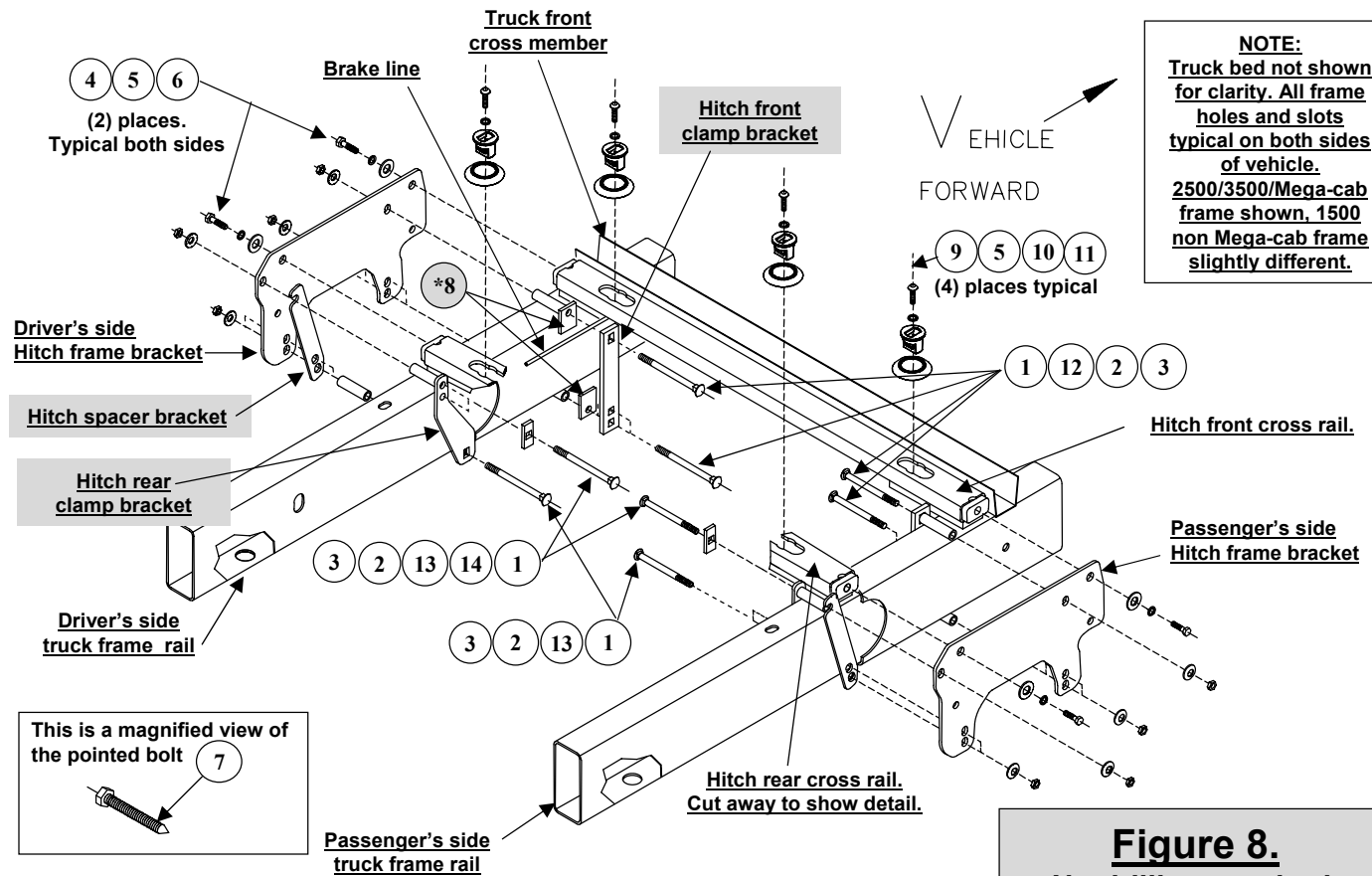

Figure 8.
No drilling required.
Clamp-on configuration.

1	Qty. (8)	1/2-13 X 4-1/2" Grade 8 Carriage bolt	9	Qty. (4)	5/8"-11 Button head screw
2	Qty.(8)	1/2" Conical washer	10	Qty. (4)	Puck
3	Qty. (8)	1/2"-13 Hex nut	11	Qty. (4)	Trim ring
4	Qty. (4)	5/8-11 X 1-1/2" Gr. 8 Hex bolt.	12	Qty. (4)	3" Tubular spacer
5	Qty. (8)	5/8" Lock washer	13	Qty. (4)	2.65" Tubular spacer, (Yellow zinc).
6	Qty. (4)	5/8" Flat washer	14	Qty. (2)	1/4" X 1" X 2" Block
7	Qty. (1)	5/8"-11 X 3-1/2" bolt, pointed			
8	Qty. (2)	1/4" X 1-1/2" X 2" Block, Off-center hole, use as needed.			

Installation Instructions

READ THOROUGHLY BEFORE BEGINNING

Part Numbers:

Signature Series Rail Kit

30074

Dodge Ram Trucks-all, including Mega-cabs

ASSEMBLY INSTRUCTIONS FOR FIFTH WHEEL INSTALLATION

TOOLS

3/16" Drill	15/16" Socket & Open End Wrench	200 lb-ft / 271 N*M Torque Wrench	Center Punch
21/32" Drill	3/4" Socket & Open End Wrench	2-1/2" Hole Saw or Knockout Punch	Tape
3/8" Hex socket	7/8" Socket & Open End wrench	Measuring Tape	Hammer

CAUTION!

Read pages 1-3 of these instructions before starting installation. Failure to do so could result in significant vehicle damage!

1. The following instructions should be used to mount the 5th wheel. Care and attention to detail will ensure a quick quality installation. Check parts against parts list to become familiar with parts in kit, **Figures 7 & 8**.
2. It may help to raise rear of truck on hoist or jack stands high enough to allow easier installation of hitch. This will provide maximum room to install the 5th wheel brackets. It is optional to remove or loosen truck bed also.



WARNING:

If the truck is raised or truck bed is to be loosened or removed be sure that truck is properly blocked and restrained to prevent the truck and or bed from falling. Failure to do so may result in the truck and or bed falling, causing death or serious injury.

3. Plastic drop-in bed liners must be cut out of the way. **Remove plastic bed liner if applicable.** Spray-in bed liners and bed mats less than 1/4" thick will work with normal installation instructions. **Note:** Consult installer for recommended curing time on spray-in liner before cutting holes through bed.

CAUTION:

Check for obstructions before drilling. Failure to do so could result in damaged fuel or brake lines, structural members, etc. CEQUENT TOWING PRODUCTS does its best to communicate tow vehicle manufacturer changes; however, it is ultimately the responsibility of the installer to prevent damage due to installation.

4. Use only **CEQUENT TOWING PRODUCTS** supplied bolts, nuts, and washers to install this kit.
5. These instructions are intended for a specific group of trucks. If these instructions do not apply to your vehicle, contact Technical Service to get proper instructions. Each frame bracket must be bolted to the vehicle frame with two bolts. Or clamped with supplied components and hardware as shown in these instructions.

CAUTION:

These instructions are guidelines only. Actual installation is the responsibility of the installer and the owner. Always measure truck and trailer before installing hitch to be sure that there is clearance at the cab and at the bumper to allow for turns.

6. Insert rails as shown in the following steps for **Non-Mega-cab** trucks, **Figures 9 through 14**.
For **Mega-cab** trucks see line **6a**, next page.

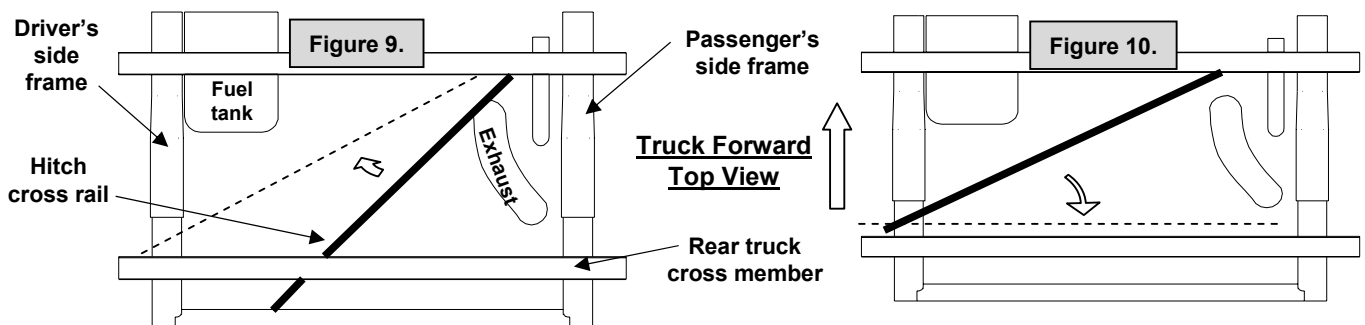

Step 1: Slide a cross rail in at an angle from driver's side wheel well between spring and bottom of frame rear of axle and over the axle and in front of the exhaust on passenger side. Lift and rotate it so that it rests on the frame (Driver's side), Figure 9.

Step 2: Continue rotating the rail up and over the exhaust so that it is against the rear truck cross member, Figure 10.

Installation Instructions

READ THOROUGHLY BEFORE BEGINNING

Part Numbers:

Signature Series Rail Kit

30074

Dodge Ram Trucks-all, including Mega-cabs

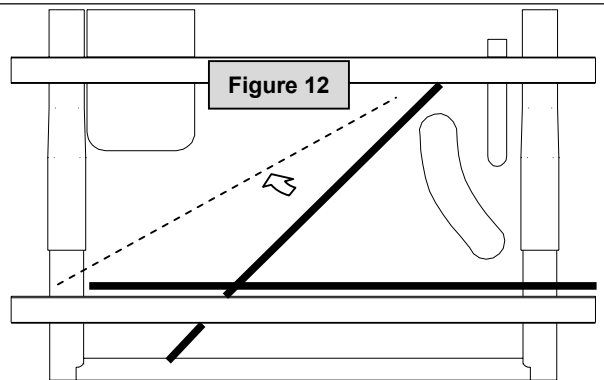
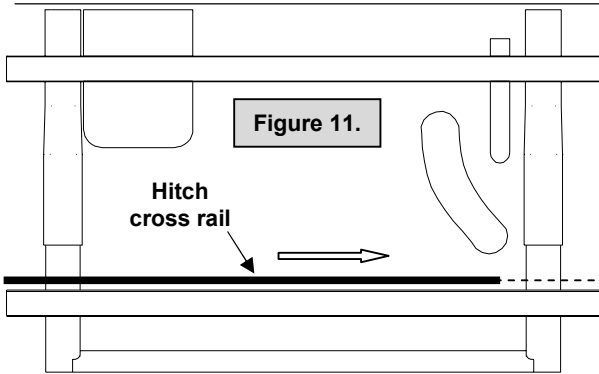

Step 3 : Slide the rail across so that it extends over the frame on the passenger side and does not rest on the frame on the Driver's side.

Truck Forward

Top View

Do not use these steps for Mega-cab trucks. See Step 6a. Below.

Step 4 : Insert the front rail in the same manner as the rear rail so that it rests on the frame (Driver's side).

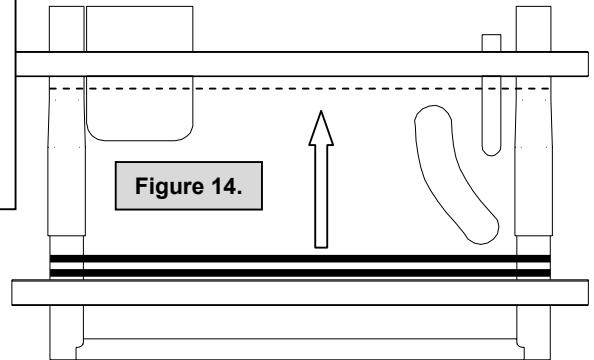
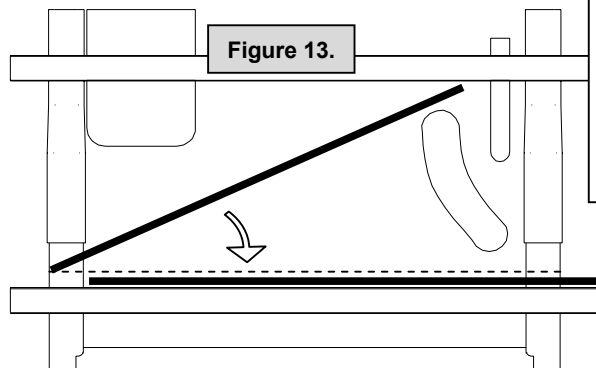

Step 5 : Rotate the rail up and over the exhaust so that it is against the rear rail.

Step 6 : Slide the front rail forward with both ends resting on the frame. Slide the rear rail to the left so that it rests evenly on both sides of the frame.

6a.

NOTE! Mega-cab trucks require that you install the cross rails in either of the options below.

Option A:

Drop exhaust tailpipe system to install hitch cross rails and follow steps 1-6 above.

Option B:

Loosen or remove truck bed from frame to allow access to slide hitch cross rails across top of frame from Driver's side wheel opening. By loosening all (4) truck bed bolts you may be able to tilt truck bed up on Driver's side to slide hitch cross rails across top of truck frame without removing bed completely.

Installation Instructions

READ THOROUGHLY BEFORE BEGINNING

Part Numbers:

Signature Series Rail Kit

30074

Dodge Ram Trucks-all, including Mega-cabs

7. After hitch cross rails are in place determine if hitch frame brackets are to be bolted to truck frame or clamped to truck frame. **If Drilling and bolting to frame proceed below.**

If clamping to frame go to line 23 and follow directions for a No-Drill clamp-on installation.

8. Loosely attach frame brackets to rails using 5/8" X 1-1/2" long bolts, flat washers & lock washers. See Figure 7 & 22.

CAUTION:

Check for obstructions before drilling. Failure to do so could result in damaged fuel or brake lines, structural members, etc. CEQUENT TOWING PRODUCTS does its best to communicate tow vehicle manufacturer changes; however, it is ultimately the responsibility of the installer to prevent damage due to installation.

9. Slide rail assembly as far rearward as possible then using frame bracket as template, and after checking rails are square with each other, drill pilot holes in frame. Enlarge pilot holes to 21/32" diameter holes, Figure 7. Optional: Spray under coating around drilled holes to prevent rusting.

CAUTION:

It is important that 21/32" drill be used for holes in chassis frame as rib-neck bolts may break if too small a hole is used and neck may not grip if too large a hole is used.

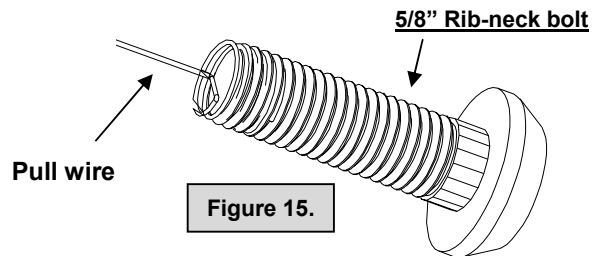

10. Thread 5/8" x 1-1/2" rib-neck bolt onto pull wire, Figure 15. Insert straight end of pull wire into access hole and guide wire through drilled mounting holes. Pull wire out through mounting hole to position rib neck bolt for connecting rail bracket and chassis rail, Figure 7. Repeat process for all four rib neck bolt locations.
11. Loosely attach frame brackets to frame using 5/8" x 1-1/2" rib-neck bolts, spacers, lock washers, and nuts; fasten until hand tight, Figure 7.
12. Using pointed bolt, Figure 16, screw pointed bolt in to the nuts that are welded to the rail assembly until a prick mark is visible in the truck bed. Access to some welded nuts can be obstructed by other truck components; the other prick mark/s must be measured from the other prick marks, Figure 17. If you have a plastic bed liner cut 19" X 4" slots in plastic drop-in bed liner measured from prick marks in truck bed. If the *Signature Series* slider fifth wheel assembly is used, then see fifth wheel slider assembly instructions for slot cut dimensions.



Figure 16.

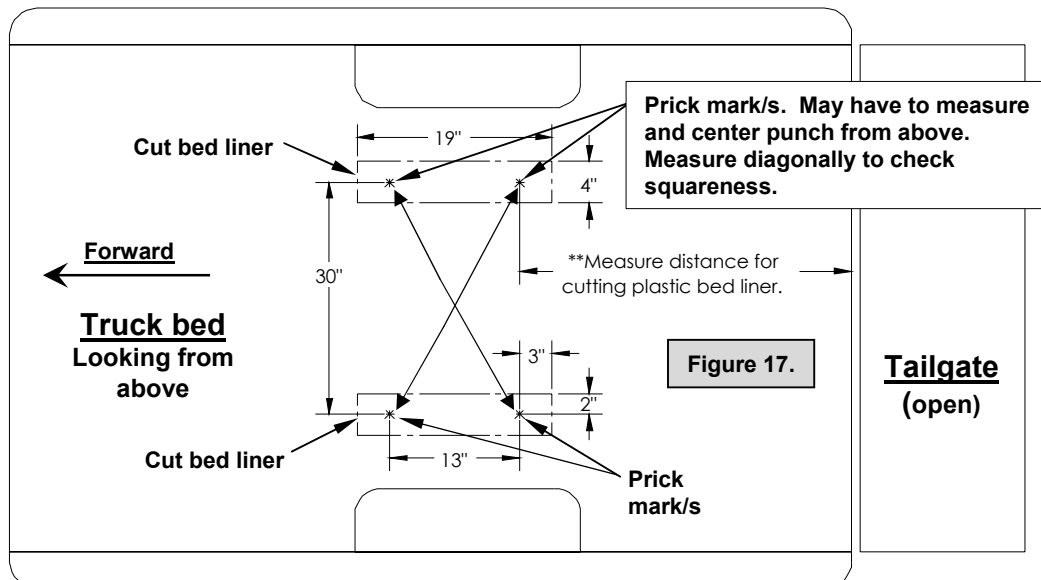

Installation Instructions

READ THOROUGHLY BEFORE BEGINNING

Part Numbers:

Signature Series Rail Kit

30074

Dodge Ram Trucks-all, including Mega-cabs

13. Remove 5/8" x 1 1/2" bolts attaching frame bracket to mounting rails. Move rails rearward or forward to prevent interference with hole drilling or punching of the truck bed.

CAUTION:

Check for obstructions before drilling. Failure to do so could result in damaged fuel or brake lines, structural members, etc. CEQUENT TOWING PRODUCTS does its best to communicate tow vehicle manufacturer changes; however, it is ultimately the responsibility of the installer to prevent damage due to installation.

14. Drill pilot holes in truck bed at prick mark locations. With hole saw or knockout punch create 2 1/2" hole centered at pilot holes. **Note:** Consult installer for recommended curing time on spray-in liner before cutting holes through bed. **Optional:** Spray under coating around 2 1/2" holes to prevent rusting.
15. Loosely reattach rails to frame bracket.
16. From truck bed attach pucks and trim rings to rails, **Figure 18**, using 5/8" button head screw and lock washer. Tighten to 100ft.lbs. / 136 N*M torque.



WARNING:

DO NOT lubricate threads. It may cause bolt failure.

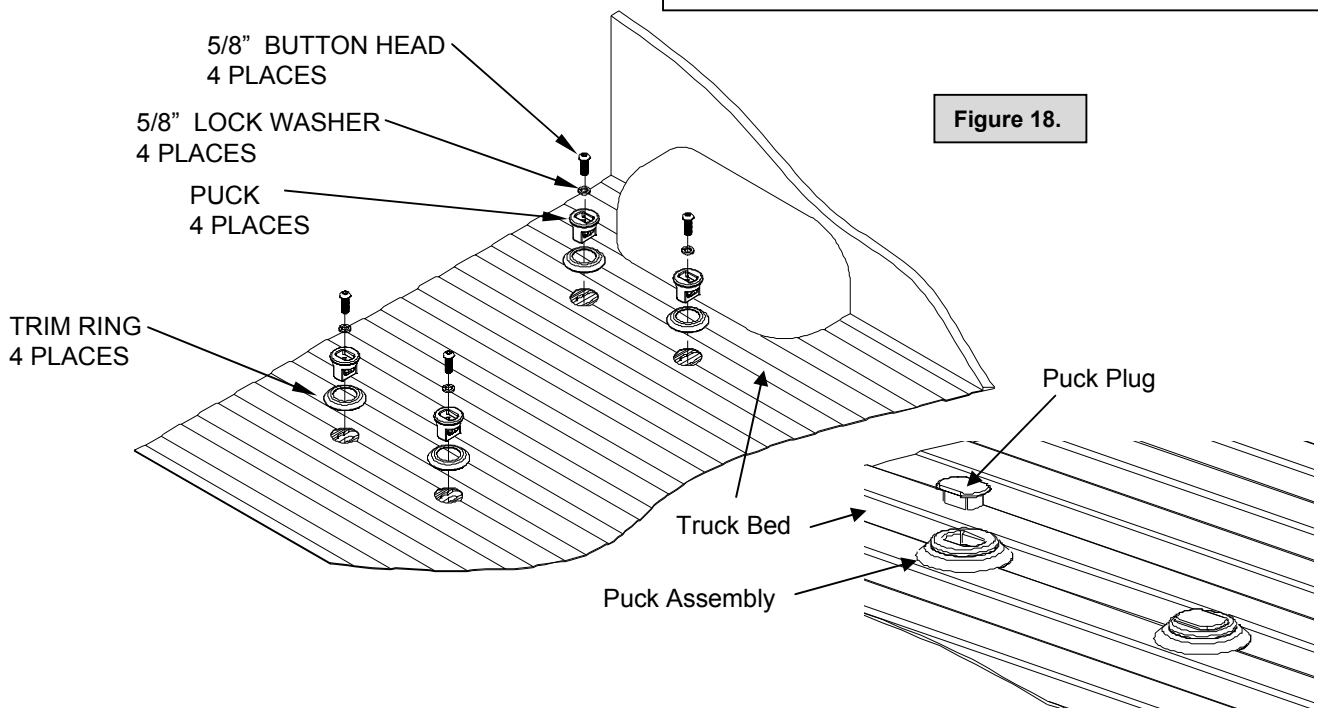

17. Insert plugs in pucks whenever they are not in use, **Figure 19**.
18. Torque hitch assembly bolts per hitch instructions.
19. Torque all 5/8" cross rail hex bolts and frame bracket hex nuts to 170ft.lbs. / 230 N*M.
20. Torque all 1/2" clamping bolts to 75 ft. lbs. / 102 N*M.
21. Replace any brake lines and spare tire that may have been removed or relocated.
22. You are done. **Check** that all essential truck components (brakes, lights, etc.) are in proper working order before returning truck to owner. **Recheck** that all hitch fasteners are torqued to proper amounts. Explain essential **Warnings** and **Cautions** to vehicle owner that are in these instructions. Explain **Warranty** that covers this hitch. Give these instructions / warranty to vehicle owner.

Figure 19.

Installation Instructions

READ THOROUGHLY BEFORE BEGINNING

Part Numbers:

Signature Series Rail Kit

30074

Dodge Ram Trucks-all, including Mega-cabs

THE FOLLOWING STEPS APPLY FOR NO-DRILL, CLAMP-ON ONLY

23. Loosely attach hitch frame brackets to hitch cross rails using 5/8" X 1-1/2" long bolts, flat & lock washers, **See Figure 8 & Figure 22.** Forward hitch cross rail will be up close to truck bed cross member.
24. Install all hitch clamps, spacer brackets & tubular spacers and bolts as shown in **Figure 8 & 22.** On 1500 non Mega-cab truck frames you will use different holes on the forward, rearward clamps & spacer brackets than on 2500/3500 & 1500/2500/3500 Mega-cab frames. This is because of frame height differences. See **Figure 20.** for proper hole usage. On some trucks including newer 1500 non Mega-cab trucks it is required to block out forward hitch clamp on inside of Driver's side frame rail to go around brake line that runs along inside of frame, **See Figure 21.** Make sure to orient blocks with longer side towards middle of frame. Tape the blocks to the clamp bracket before installing. Make sure to use shorter **YELLOW ZINC** tubular spacers on all rearward clamps, **See Figure 22.**
25. When all brackets are properly positioned and square with each other and the truck frame and watching not to clamp down on any brake lines, wiring or other vehicle apparatus you can loosely tighten clamping hardware. **Do not** torque clamping or cross rail bolts yet.
26. Return to Line 12 previous pages and proceed from there.

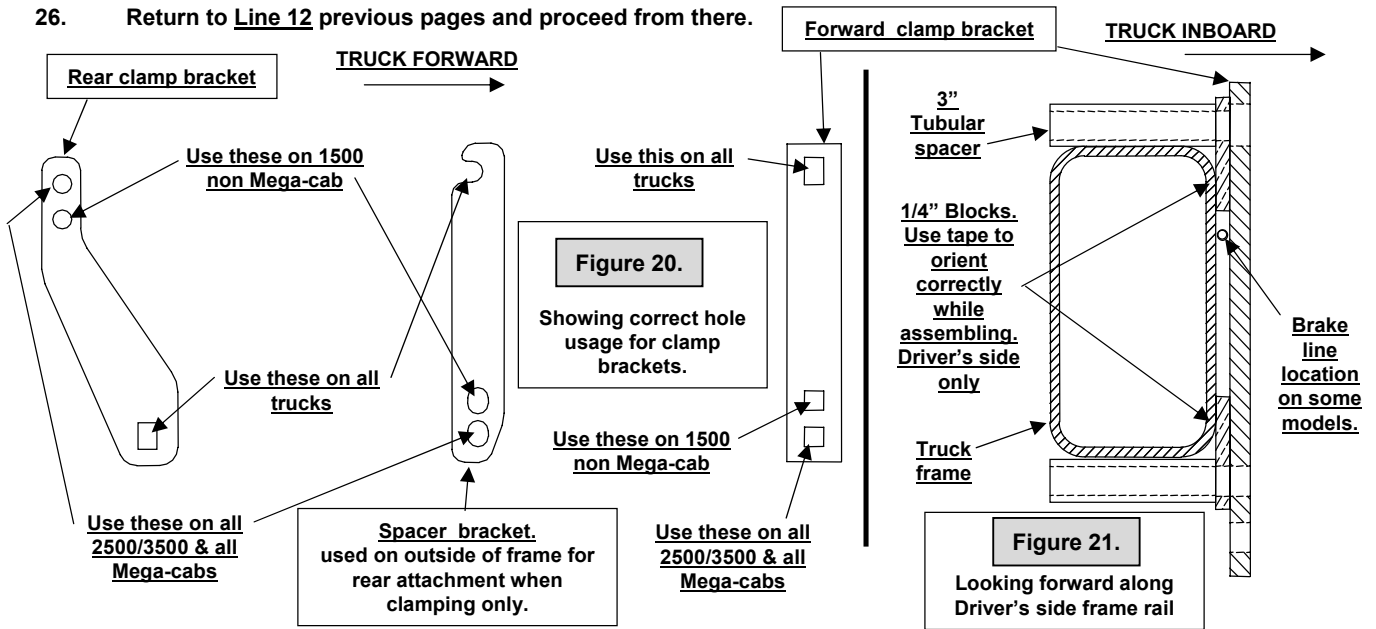

Blow-up of Figure 8. Driver's side shown, Passenger's side opposite

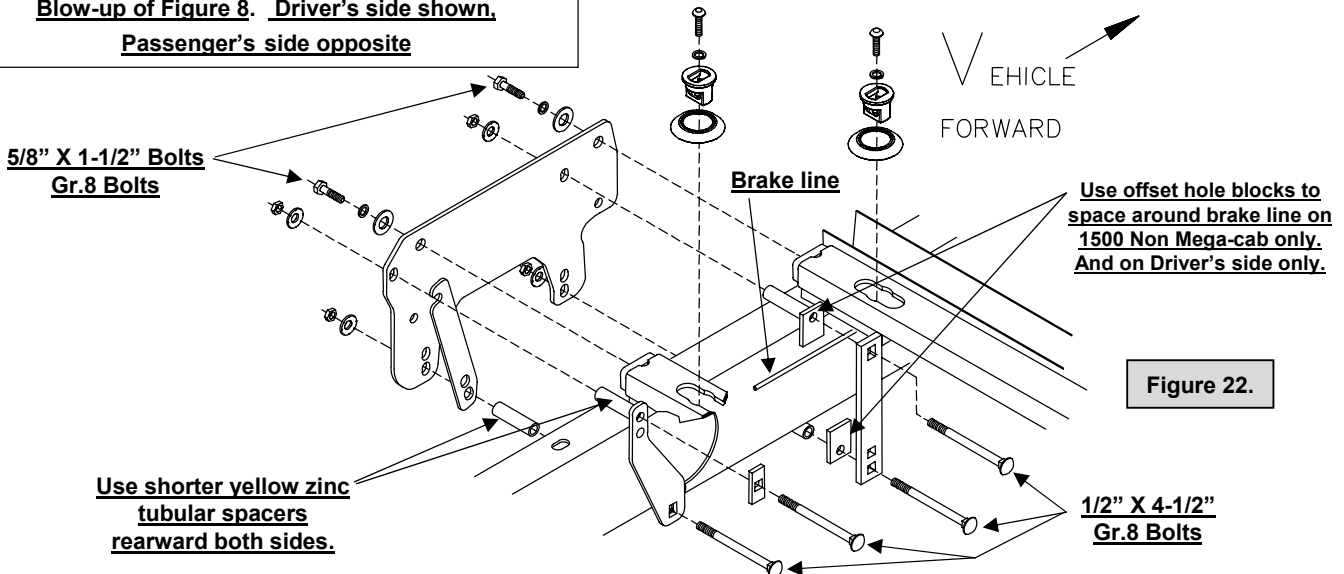

Installation Instructions

READ THOROUGHLY BEFORE BEGINNING

Part Numbers:

Signature Series Rail Kit

30074

Dodge Ram Trucks-all, including Mega-cabs

NOTES

SEVEN YEAR LIMITED WARRANTY

Hitches - Custom Receivers

Cequent Towing Products warrants the *Signature Series* 5th Wheel Hitch Mounting Kits from date of purchase against defects in material and workmanship under normal use and service, ordinary wear and tear excepted, for 7 years of ownership to the original consumer purchaser when a **Cequent Towing Products** *Signature Series* 5th Wheel Hitch is used.

Cequent Towing Products will replace FREE OF CHARGE any part which proves defective in material or workmanship when presented to any **Cequent Towing Products** dealer, **Cequent Towing Products** Warehouse or returned to factory. TRANSPORTATION CHARGES PREPAID, at the address below. THIS WARRANTY IS LIMITED TO DEFECTIVE PARTS REPLACEMENT ONLY. LABOR CHARGES AND/OR DAMAGE INCURRED IN INSTALLATION OR REPLACEMENT AS WELL AS INCIDENTAL AND CONSEQUENTIAL DAMAGES CONNECTED THEREWITH ARE EXCLUDED.

Some states do not allow the exclusion or limitation of incidental or consequential damages, so the above limitation or exclusion may not apply to you.

Any damage to the *Signature Series* 5th Wheel Hitch as a result of misuse, abuse, neglect, accident, improper installation, or any use violative of instructions furnished by us, WILL VOID THE WARRANTY.

This warranty gives you specific legal rights, and you may also have other rights which vary from state to state. In the event of a problem with warranty service or performance, you may be able to go to a small claims court, or a federal district court.

Cequent Towing Products, Inc.
4774 Anchor court West
Plymouth, Michigan 48170