



# 31012 INSTALLATION INSTRUCTIONS



Safety glasses should be worn at all times while installing this product.

**YEARS: 2007-CURRENT**

**MAKE: CHEVROLET, GMC, & CADILLAC**

**MODEL: TAHOE, AVALANCHE, YUKON, & ESCALADE**

**STYLE: SUV**

EXCLUDES: HYBRIDS, 2500

**WARNING: NEVER EXCEED YOUR VEHICLE MANUFACTURER'S RECOMMENDED TOWING CAPACITY**

**WEIGHT CARRYING:**  
**TRAILER WEIGHT: 5,000 LBS.**  
**TONGUE WEIGHT: 500 LBS.**

**GROSS LOAD CAPACITY WHEN USED AS A STRAIGHT LINE PULL:**  
**9,000 LBS MAX.**

**INSTALLATION TIME: 45 MIN.**

THE INSTALL TIME LISTED IS FOR PROFESSIONAL INSTALLERS. IF YOU ARE HESITANT TO UNDERTAKE THIS TASK ON YOUR OWN, CONTACT AN AUTHORIZED CURT INSTALLER FOR ADDITIONAL ASSISTANCE.



**INSTALLATION REQUIRES:**

 <b>RATCHET</b>	 <b>TORQUE WRENCH</b>	 <b>3/4"</b> <b>SOCKET</b>
 <b>POWER DRILL</b>	 <b>DRILL BIT 17/32"</b>	 <b>AVIATION SHEARS</b>
 <b>CENTER PUNCH</b>		

**INSTALLATION TIPS:**

- BEFORE YOU BEGIN INSTALLATION, READ ALL INSTRUCTIONS THOROUGHLY.
- TO EASE INSTALLATION, 2 PEOPLE MAY BE REQUIRED.
- USING PROPER TOOLS WILL GREATLY IMPROVE THE QUALITY OF THE INSTALL AND REDUCE THE TIME REQUIRED.
- NEED HELP OR HAVE SOME QUESTIONS? CALL TECHNICAL SUPPORT AT 800.798.0813

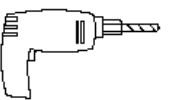
**LEVEL OF DIFFICULTY: MODERATE**

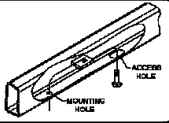
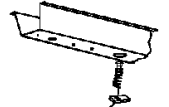
<b>EASY</b>	<b>MODERATE</b>	<b>HARD</b>
	DRILLING REQUIRED	
	FASCIA TRIMMING OR REMOVAL REQUIRED	
	FISHWIRE REQUIRED	
	REVERSE FISHWIRE	

**VEHICLE PHOTO:**



REPRESENTATIVE PHOTO

**HITCH ILLUSTRATION:**

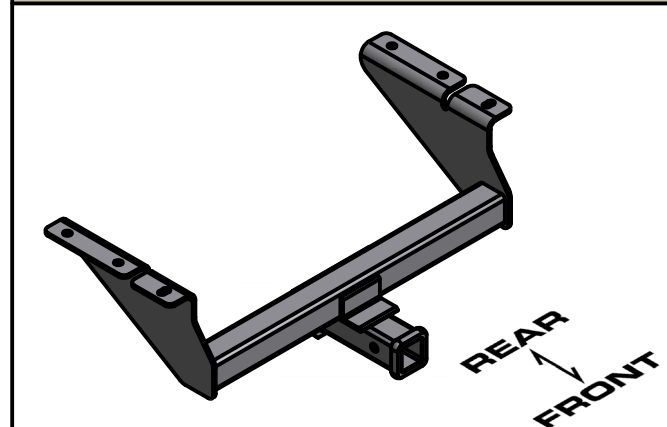

MAKE SURE YOUR HITCH MATCHES

**PERIODICALLY CHECK THIS RECEIVER HITCH TO ENSURE ALL FASTENERS ARE TIGHT AND ALL STRUCTURAL COMPONENTS ARE SOUND**

CURT Manufacturing Inc. warrants this product to be free of defects in material and/or workmanship at the time of retail purchase by the original purchaser. If the product is found to be defective, Curt Manufacturing Inc. may repair or replace the product at their option, when the product is returned, prepaid, with proof of purchase. Alteration to, misuse of, or improper installation of this product voids the warranty. Curt Manufacturing Inc.'s liability is limited to repair or replacement of products found to be defective, and specifically excludes liability for incidental or consequential loss or damage.

For more information log onto [www.curtmfg.com](http://www.curtmfg.com), & for helpful towing tips log onto [www.hitchinfo.com](http://www.hitchinfo.com)

## INSTALLATION WALKTHROUGH:

Parts List			
ITEM	QTY	PART NUMBER	DESCRIPTION
1	6	HFN 1213	HEX FLANGE NUT
2	2	1_2 FISHWIRE	1/2" FISHWIRE
3	6	1/2-13 x 1 3/4	CARRIAGE BOLT
4	6	CM-SP6	.250 x 1.00 x 3.00" SQUARE HOLE SPACER

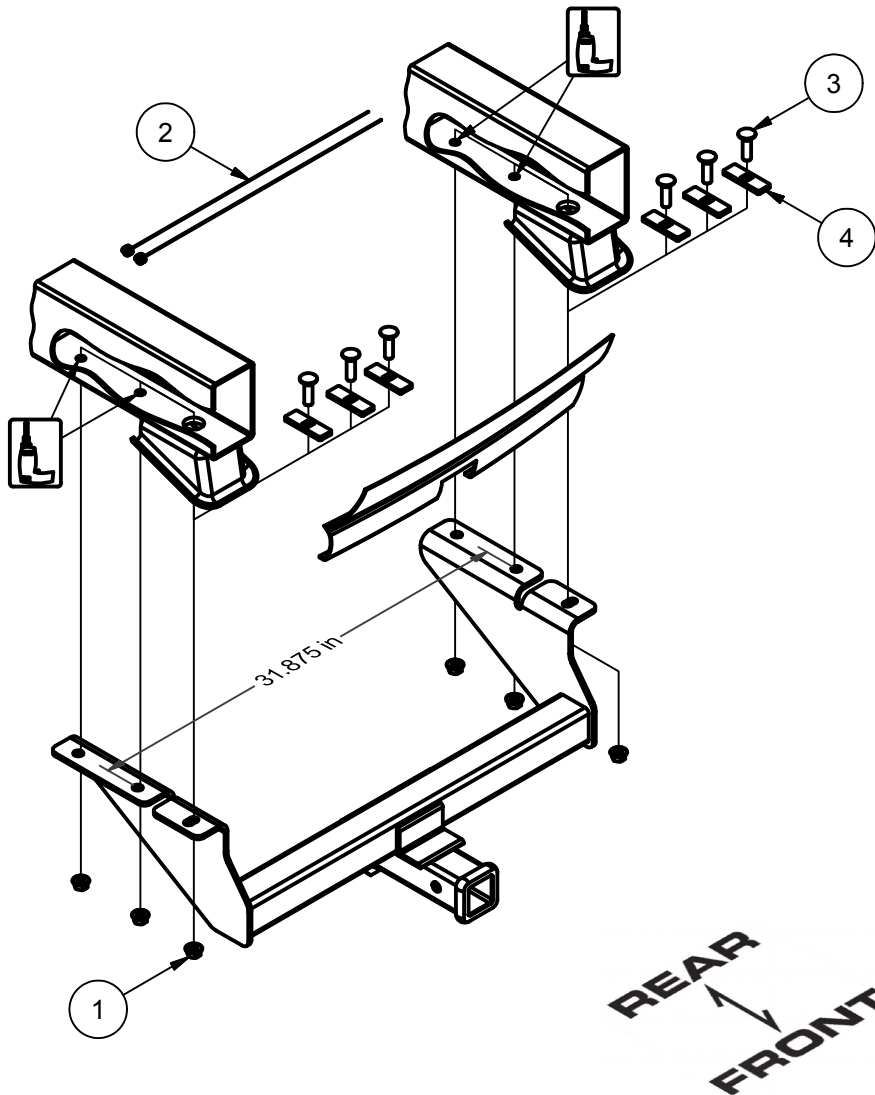

1. Mark and trim lower fascia, or remove lower fascia and return to owner. **Note:** Check for proper fit prior to trimming.

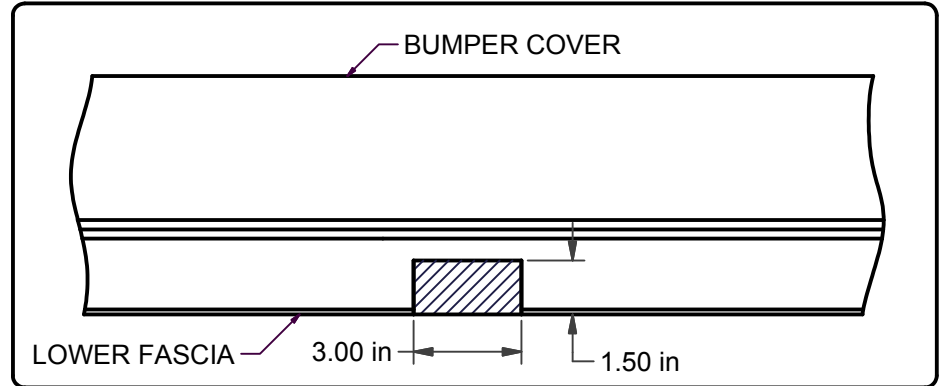

2. Raise hitch into position aligning the access hole with the forward most hole in hitch.

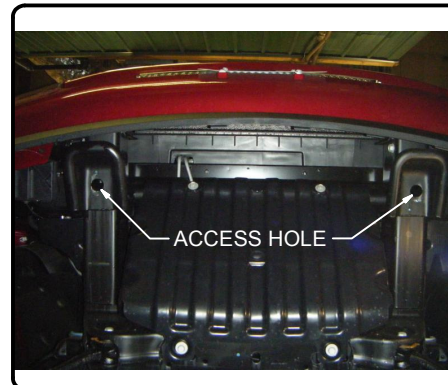

## INSTALLATION WALKTHROUGH:

3. Mark the (4) drill holes in both frame rails using a center punch.



4. Lower hitch and drill (4) 17/32" holes marked in Step (3).

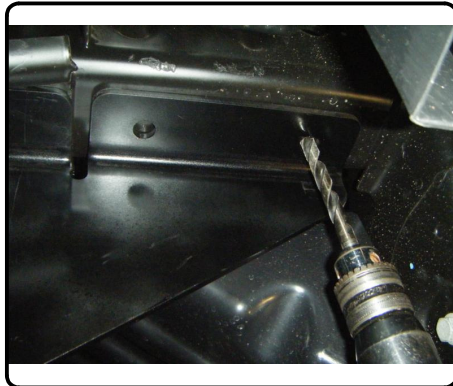
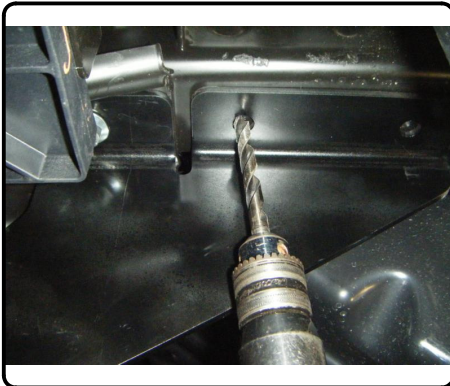

5. Fishwire 1/2-13 x 1 3/4" carriage bolts and SP6 spacers through the access holes and out drilled holes.

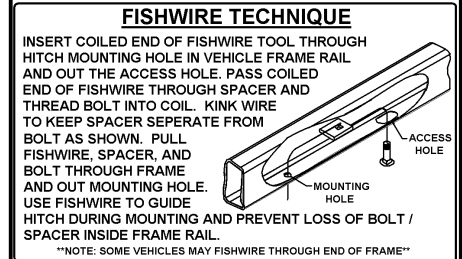

6. Reverse fishwire 1/2-13 x 1 3/4" carriage bolts and SP6 spacers into the access holes.

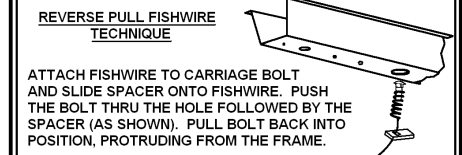

## INSTALLATION WALKTHROUGH:

7. Raise hitch into position and secure with 1/2-13 flange nuts.



8. Torque all 1/2" fasteners to 75 ft-lbs.

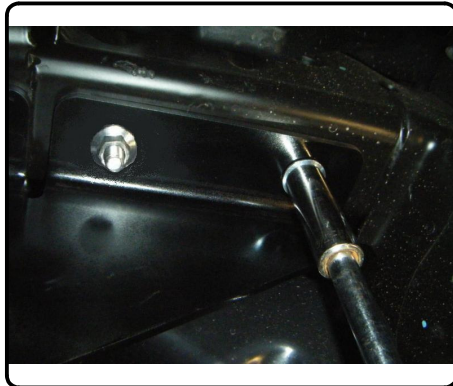

9. Hitch shown installed properly.

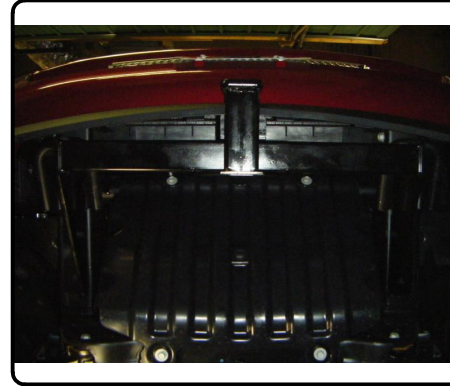

10. Installation is now complete.



**31012****CHEVROLET TAHOE, CHEVROLET AVALANCHE,  
GMC YUKON, CADILLAC ESCALADE & SUBURBAN LTZ****8/3/2011****EXCLUDES: HYBRIDS, 2500****GROSS LOAD CAPACITY WHEN USED AS A WEIGHT CARRYING HITCH: 5,000 LBS. TRAILER WEIGHT & 500 LBS. TONGUE WEIGHT.****GROSS LOAD CAPACITY WHEN USED AS A STRAIGHT LINE PULL: 9,000 LBS. MAX. LINE PULL.****\*\*\* DO NOT EXCEED VEHICLE MANUFACTURER'S RECOMMENDED TOWING CAPACITY. \*\*\*****HAVING INSTALLATION QUESTIONS? CALL TECHNICAL SUPPORT AT 1-800-798-0813**

Parts List			
ITEM	QTY	PART NUMBER	DESCRIPTION
1	6	HFN 1213	HEX FLANGE NUT
2	2	1_2 FISHWIRE	1/2" FISHWIRE
3	6	1/2-13 x 1 3/4	CARRIAGE BOLT
4	6	CM-SP6	.250 x 1.00 x 3.00" SQUARE HOLE SPACER

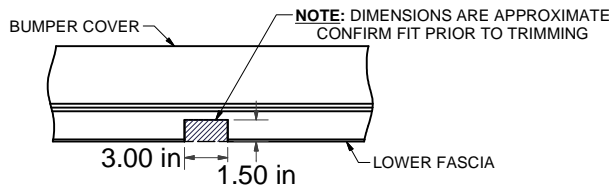
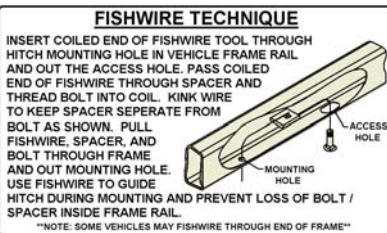
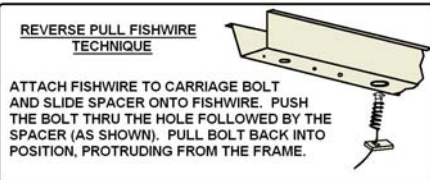
**FASCIA TRIM DETAIL****HITCH WEIGHT: 37 LBS.****INSTALL TIME**

PROFESSIONAL: 45 MINUTES

NOVICE (DIY): 90 MINUTES

**INSTALL NOTES:**

- DRILLING REQUIRED
- FASCIA TRIMMING OR REMOVAL REQUIRED (EXCLUDING LT MODELS)

**TOOLS REQUIRED**

- RATCHET
- TORQUE WRENCH
- 3/4" SOCKET
- AVIATION SHEARS
- DRILL
- 17/32" DRILL BIT
- CENTER PUNCH

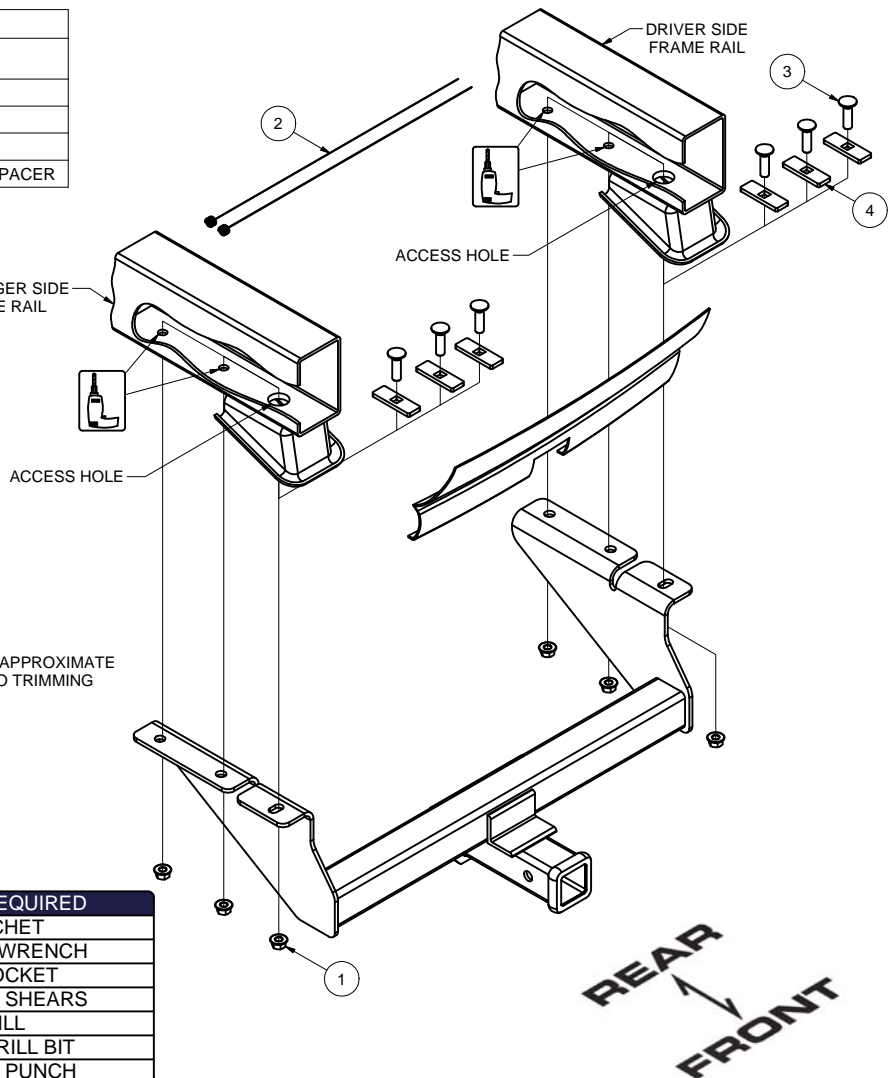
**INSTALLATION STEPS**

1. Mark and trim lower fascia, or remove lower fascia and return to owner. (See fascia trim detail) (Excluding LT models)
2. Raise hitch into position aligning the access hole with the forward-most hole in hitch.
3. Using the hitch as a template mark the (4) drill holes in each frame rail with a center punch.
4. Lower hitch and drill the (4) 17/32" holes marked in Step (3).
5. Fishwire 1/2-13 x 1-3/4" carriage bolts and SP6 spacers through drilled holes. (See fishwire diagram)
6. Reverse fishwire 1/2-13 x 1-3/4" carriage bolts and SP6 spacers into the access holes. (See reverse fishwire diagram)
7. Raise hitch and secure with 1/2-13 flange nuts.
8. Torque all 1/2" fasteners to 75 ft-lbs.

PERIODICALLY CHECK THIS RECEIVER HITCH TO ENSURE THAT ALL FASTENERS ARE TIGHT AND THAT ALL STRUCTURAL COMPONENTS ARE SOUND.

Curt Manufacturing Inc., warrants this product to be free of defects in material and/or workmanship at the time of retail purchase by the original purchaser. If the product is found to be defective, Curt Manufacturing Inc., may repair or replace the product, at their option, when the product is returned, prepaid, with proof of purchase. Alteration to, misuse of, or improper installation of this product voids the warranty. Curt Manufacturing Inc.'s liability is limited to repair or replacement of products found to be defective, and specifically excludes liability for incidental or consequential loss or damage.

# CHEVROLET TAHOE, CHEVROLET AVALANCHE, GMC YUKON, & CADILLAC ESCALADE

EXCLUDES: HYBRIDS, 2500

**\*\*\*DO NOT EXCEED VEHICLE MANUFACTURER'S RECOMMENDED TOWING CAPACITY \*\*\*.**

## FRONT MOUNTED ACCESSORIES

1) Do not exceed front axle Gross Weight Rating (GAWR). Consult owners manual or specification plate located on driver's door frame. Measure gross front axle weight by placing front wheels of loaded vehicle on a scale.

**WARNING:** Exceeding GAWR may overload the front axle and/or suspension. This could result in **accident, property damage and personal injury.**

- 2) Reposition front mounted license plate if obstructed.
- 3) Do not obstruct vehicle lights.
- 4) Allow free air flow into grille opening.
- 5) Rear wheel traction may be reduced. This could effect handling. Reduce speed and drive with caution.
- 6) Accessories extend front of vehicle. This may reduce approach angle. Use caution when parking and maneuvering.
- 7) Do not obstruct driver view.

## VEHICLE RECOVERY AND WINCHING TIPS

1) Use OEM tow hooks, recovery eyes or a clevis mount for attachment of a tow strap or winch cable.

**WARNING: NEVER** use a ball and/or ball mount as an anchor point for tow strap or winch cable. Severe personal injury or death could result.

- 2) Observe winch manufacturer's recommendations, cautions and warnings.
- 3) Attach return cable to tow hook or recovery eye when using a snatch block (See figure 1).

**CAUTION:** Do not attach return cable to winch mount. This may overload winch mount and/or front mounted receiver.

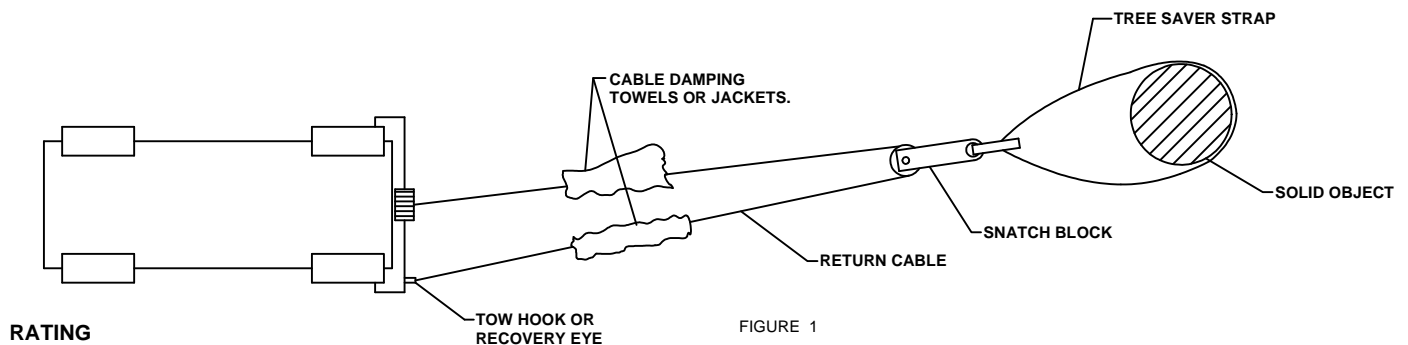

## RATING

For **Maximum** line pull rating, winch cable must not exceed:  
- 15 degree angle up or down from horizontal (See Figure 2).  
- 45 degree angle left or right from straight ahead (See Figure 3).

**CAUTION:** Exceeding the maximum line pull rating may over load winch, winch mount, and/or front mounted receiver.

