

**31014****99-03 FORD SUPER DUTY F-250 & F-350**

1/7/2011

WITH BLOCKER BEAM ONLY

**GROSS LOAD CAPACITY WHEN USED AS A WEIGHT CARRYING HITCH: 5,000 LBS. TRAILER WEIGHT & 500 LBS. TONGUE WEIGHT.****GROSS LOAD CAPACITY WHEN USED AS A STRAIGHT LINE PULL: 9,000 LBS. MAX. LINE PULL.**

\*\*\* DO NOT EXCEED VEHICLE MANUFACTURER'S RECOMMENDED TOWING CAPACITY. \*\*\*

**HAVING INSTALLATION QUESTIONS? CALL TECHNICAL SUPPORT AT 1-800-798-0813**

Parts List			
ITEM	QTY	PART NUMBER	DESCRIPTION
1	2	3/8 x 1 1/4	SELF-THREADING
2	1	CM-31014-DS-MP	.250" DRIVER SIDE MOUNTING PLATE
3	1	CM-31014-PS-MP	.250" PASSENGER SIDE MOUNTING PLATE

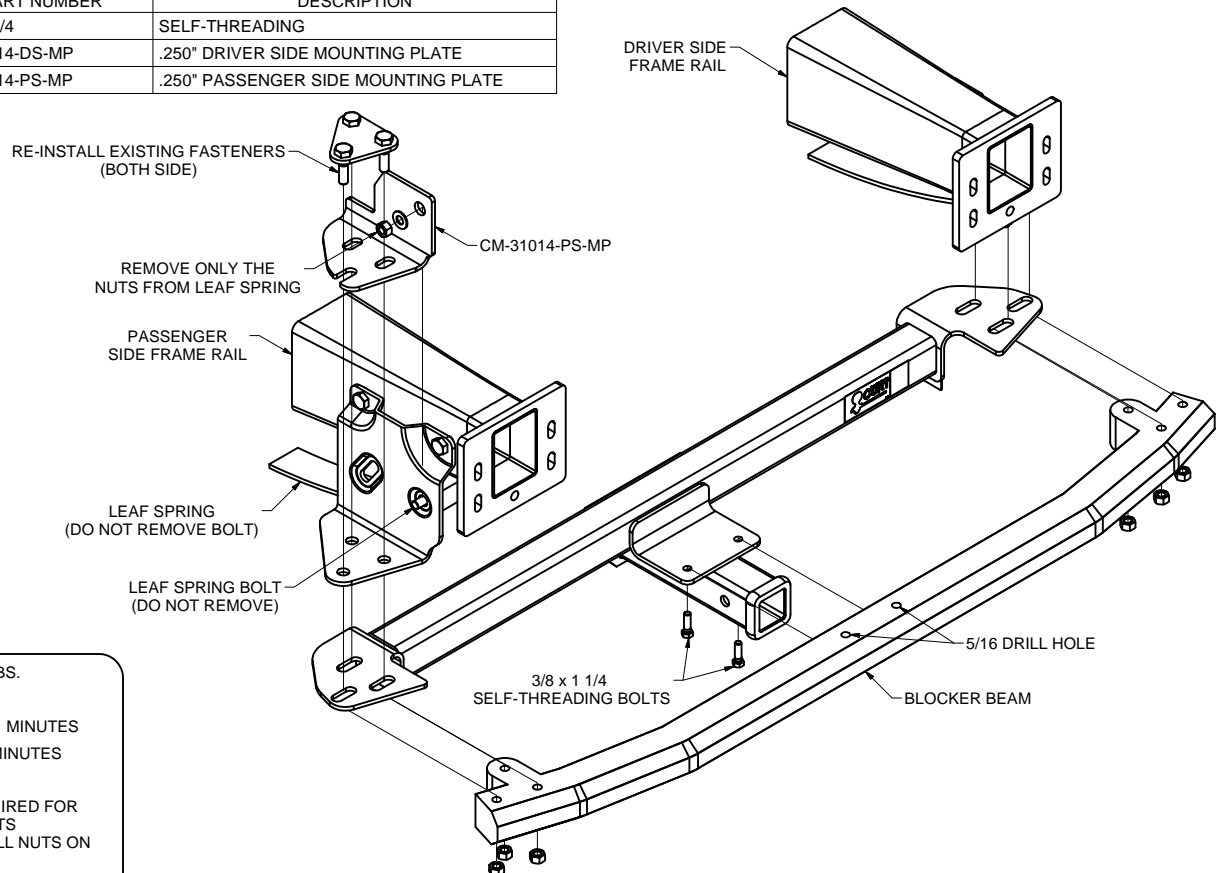

HITCH WEIGHT: 40 LBS.

INSTALL TIME

PROFESSIONAL: 45 MINUTES

NOVICE (DIY): 90 MINUTES

INSTALL NOTES:

- PRE-DRILLING REQUIRED FOR SELF-TREADED BOLTS
- REMOVE / RE-INSTALL NUTS ON LEAF SPRING

**INSTALLATION STEPS**

- 1) Remove the blocker beam from the truck. This is the small sub-bumper behind the air dam. There are three fasteners located at each end of the beam. The air dam stays in place with no cutting required.
- 2) Remove the nuts only from the bolts that go through the front of the leaf springs. **WARNING: Do not remove or attempt to remove the bolts from their location. Doing so could allow the front of the vehicle to drop down suddenly!**
- 3) Install the upper brackets to the blocker beam brackets. **WARNING: Be sure to securely reinstall the nuts (at driver's and passenger's side into the bolts that go through the front of the leaf springs. Failing to do this could allow the bolts to come out and the front of the vehicle to drop down suddenly without warning.**
- 4) Position the receiver assembly around the blocker beam, then move into position adjusting side to side as needed to clear leaf springs and securely attach them to the blocker beam brackets.
- 5) On each side of the receiver tube there is a tab with a hole that lines up with the bottom of the blocker beam. Use the hole as a guide and drill 5/16" hole into the blocker beam. Turn the 3/8" self-threading bolt securely into each tab.
- 6) Torque all 3/8" fasteners to 30 ft-lb

PERIODICALLY CHECK THIS RECEIVER HITCH TO ENSURE THAT ALL FASTENERS ARE TIGHT AND THAT ALL STRUCTURAL COMPONENTS ARE SOUND.

Curt Manufacturing Inc., warrants this product to be free of defects in material and/or workmanship at the time of retail purchase by the original purchaser. If the product is found to be defective, Curt Manufacturing Inc., may repair or replace the product, at their option, when the product is returned, prepaid, with proof of purchase. Alteration to, misuse of, or improper installation of this product voids the warranty. Curt Manufacturing Inc.'s liability is limited to repair or replacement of products found to be defective, and specifically excludes liability for incidental or consequential loss or damage.