

31043

# 1988-2000 CHEVY/GMC PICKUP AND SUBURBAN 2500 & 3500 SERIES- 2WD ONLY

5/12/2009

GROSS LOAD CAPACITY WHEN USED AS A WEIGHT CARRYING HITCH: 5000 LBS. TRAILER WEIGHT & 500 LBS. TONGUE WEIGHT.

GROSS LOAD CAPACITY WHEN USED AS A STRAIGHT LINE PULL: 9,000 LBS. MAX. LINE PULL.

\*\*\* DO NOT EXCEED VEHICLE MANUFACTURER'S RECOMMENDED TOWING CAPACITY. \*\*\*

HAVING INSTALLATION QUESTIONS? CALL TECHNICAL SUPPORT AT 1-800-798-0813

### Parts List

ITEM	QTY	PART NUMBER	DESCRIPTION
1	6	HFN 1213	HEX FLANGE NUT
2	6	1/2-13 x 1 3/4	CARRIAGE BOLT
3	6	CM-SP12	.250 x 1.00 x 2.00" SQUARE HOLE SPACER
4	4	1/2 - 13 x 2 1/4	CARRIAGE BOLT
5	2	1_2 FISHWIRE	1/2" FISHWIRE

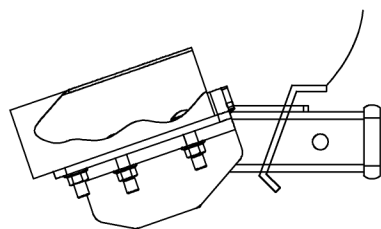

INSTALLED HITCH POSITION

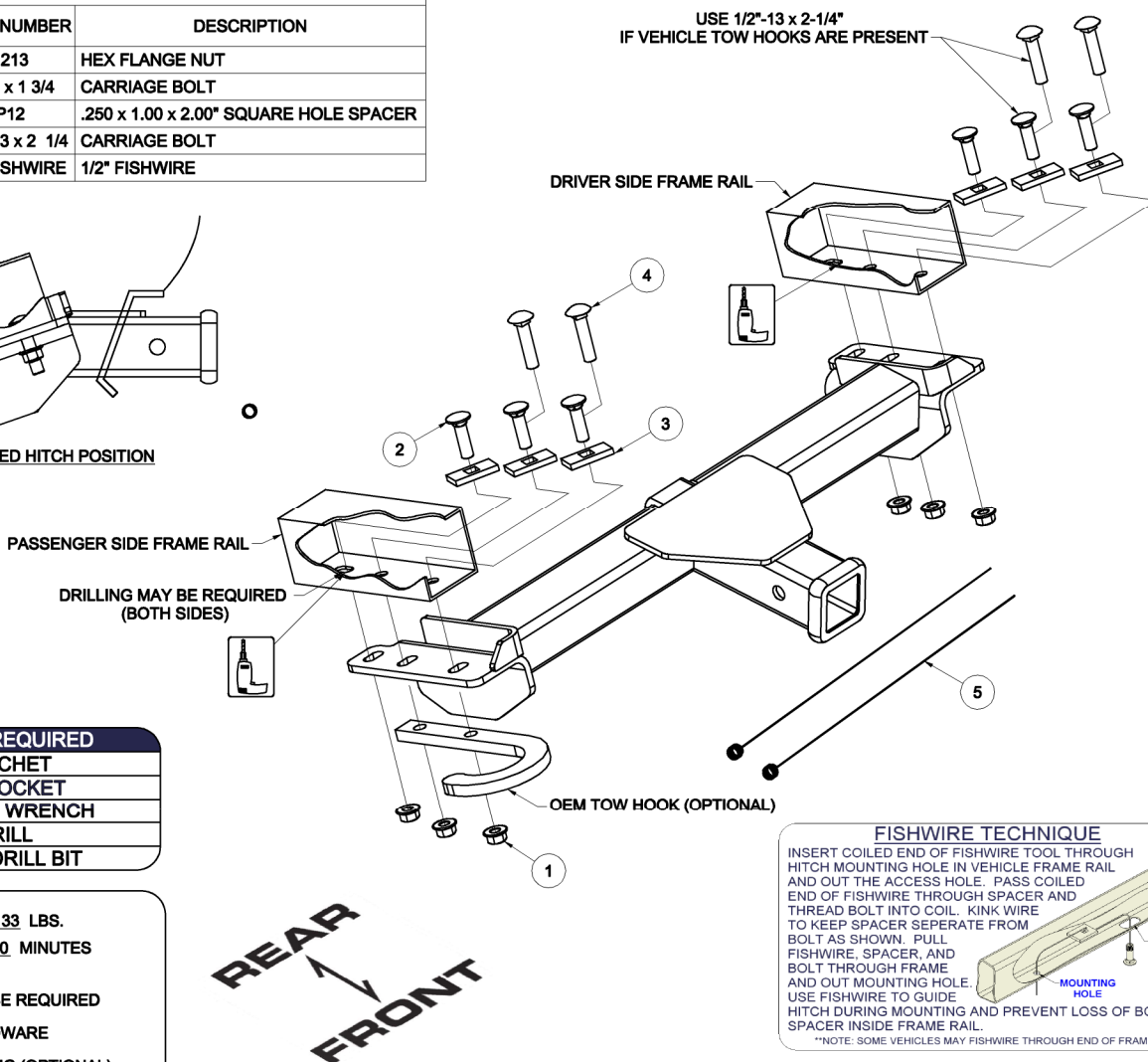

### TOOLS REQUIRED

RATCHET

3/4" SOCKET

TORQUE WRENCH

DRILL

17/32" DRILL BIT

HITCH WEIGHT: 33 LBS.

INSTALL TIME: 30 MINUTES

INSTALL NOTES:

-DRILLING MAY BE REQUIRED

-FISHWIRE HARDWARE

-FASCIA TRIMMING (OPTIONAL)

## INSTALLATION STEPS

1. If present, remove lower fascia under the bumper.
2. If present, remove vehicle tow hooks.
3. Fishwire a 1/2" carriage bolt and CM-SP12 spacer into each hole. (See Fishwire Technique)
4. Raise the hitch into position over the 1/2" carriage bolts and secure using (6) 1/2" flange nuts. (If vehicle tow hooks are present, reinstall using the 1/2"-13 x 2-1/4" carriage bolt, rather than the 1/2"-13 x 1-3/4" as shown)
5. If the large slot in the frame is not present, drill a 17/32" hole using the hitch as a template.
6. Fishwire remaining 1/2"-13 x 1 3/4" carriage bolts and spacers, secure with 1/2" flange nuts.
7. Torque all 1/2" hardware to 75 ft-lbs.
8. If customer desires, trim the lower fascia removed in step one and reinstall.

**PERIODICALLY CHECK THIS RECEIVER HITCH TO ENSURE THAT ALL FASTENERS ARE TIGHT AND THAT ALL STRUCTURAL COMPONENTS ARE SOUND.**

Curt Manufacturing Inc., warrants this product to be free of defects in material and/or workmanship at the time of retail purchase by the original purchaser. If the product is found to be defective, Curt Manufacturing Inc., may repair or replace the product, at their option, when the product is returned, prepaid, with proof of purchase. Alteration to, misuse of, or improper installation of this product voids the warranty. Curt Manufacturing Inc.'s liability is limited to repair or replacement of products found to be defective, and specifically excludes liability for incidental or consequential loss or damage.

31043

## 1988-2000 CHEVY/GMC PICKUP & SUBURBAN 2500 & 3500 SERIES- 2WD ONLY

**\*\*\*DO NOT EXCEED VEHICLE MANUFACTURER'S RECOMMENDED TOWING CAPACITY \*\*\*.**

### FRONT MOUNTED ACCESSORIES

1) Do not exceed front axle Gross Weight Rating (GAWR). Consult owners manual or specification plate located on driver's door frame. Measure gross front axle weight by placing front wheels of loaded vehicle on a scale.

**WARNING:** Exceeding GAWR may overload the front axle and/or suspension. This could result in **accident, property damage and personal injury.**

- 2) Reposition front mounted license plate if obstructed.
- 3) Do not obstruct vehicle lights.
- 4) Allow free air flow into grille opening.
- 5) Rear wheel traction may be reduced. This could effect handling. Reduce speed and drive with caution.
- 6) Accessories extend front of vehicle. This may reduce approach angle. Use caution when parking and maneuvering.
- 7) Do not obstruct driver view.

### VEHICLE RECOVERY AND WINCHING TIPS

1) Use OEM tow hooks, recovery eyes or a clevis mount for attachment of a tow strap or winch cable.

**WARNING:** NEVER use a ball and/or ball mount as an anchor point for tow strap or winch cable. Severe personal injury or death could result.

- 2) Observe winch manufacturer's recommendations, cautions and warnings.
- 3) Attach return cable to tow hook or recovery eye when using a snatch block (See figure 1).

**CAUTION:** Do not attach return cable to winch mount. This may overload winch mount and/or front mounted receiver.

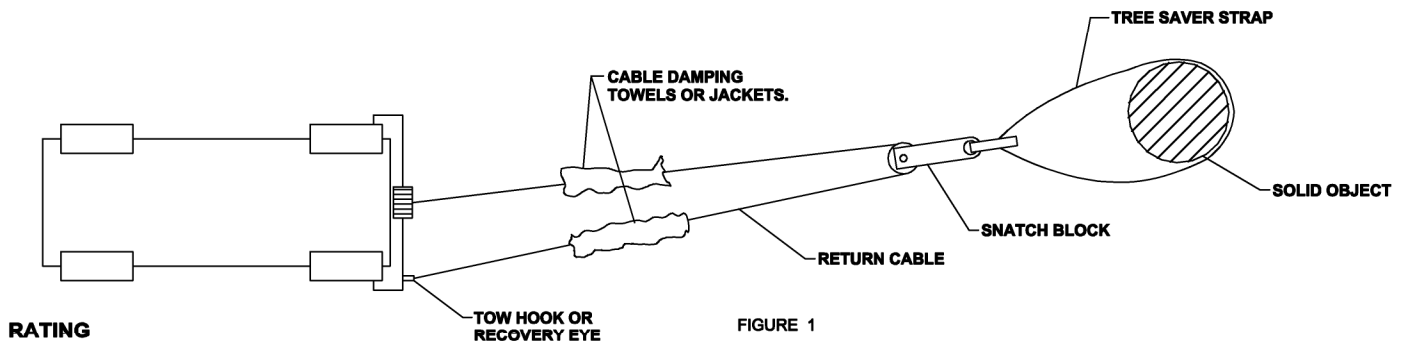

- For **Maximum** line pull rating, winch cable must not exceed:
- 15 degree angle up or down from horizontal (See Figure 2).
  - 45 degree angle left or right from straight ahead (See Figure 3).

**CAUTION:** Exceeding the maximum line pull rating may over load winch, winch mount, and/or front mounted receiver.

