

YEARS: 2009-CURRENT

MAKE: FORD

MODEL: F-150

STYLE: ALL

WARNING: NEVER EXCEED YOUR VEHICLE MANUFACTURER'S RECOMMENDED TOWING CAPACITY

WEIGHT CARRYING:
 TRAILER WEIGHT: 5,000 LBS.
 TONGUE WEIGHT: 500 LBS.

GROSS LOAD CAPACITY WHEN USED AS A STRAIGHT LINE PULL:
 9,000 LBS MAX.

PRO INSTALL TIME: 30 MIN.
NOVICE INSTALL TIME: 60 MIN.

IF YOU ARE HESITANT TO UNDERTAKE THIS TASK ON YOUR OWN, CONTACT AN AUTHORIZED CURT INSTALLER FOR ADDITIONAL ASSISTANCE.

INSTALLATION REQUIRES:

		3/4" 15/16" 15MM
TORQUE WRENCH	RATCHET	SOCKET
SAFETY GLASSES	AVIATION SHEARS	MASKING TAPE
MARKER		

INSTALLATION TIPS:

- BEFORE YOU BEGIN INSTALLATION, READ ALL INSTRUCTIONS THOROUGHLY.
- TO EASE INSTALLATION, 2 PEOPLE MAY BE REQUIRED.
- USING PROPER TOOLS WILL GREATLY IMPROVE THE QUALITY OF THE INSTALL AND REDUCE THE TIME REQUIRED.
- NEED HELP OR HAVE SOME QUESTIONS? CALL TECHNICAL SUPPORT AT 800.798.0813

LEVEL OF DIFFICULTY: MODERATE

EASY	MODERATE	CHALLENGING
	4X4 MODELS - TRIM 1 3/8" x 3 1/2" 4X2 MODELS - TRIM 1" x 3 1/2"	
	FISHWIRE (2) 5/8" BOLTS	
	NO DRILLING REQUIRED	
	ON 2011 AND NEWER REMOVE LOWER AIR DAM	

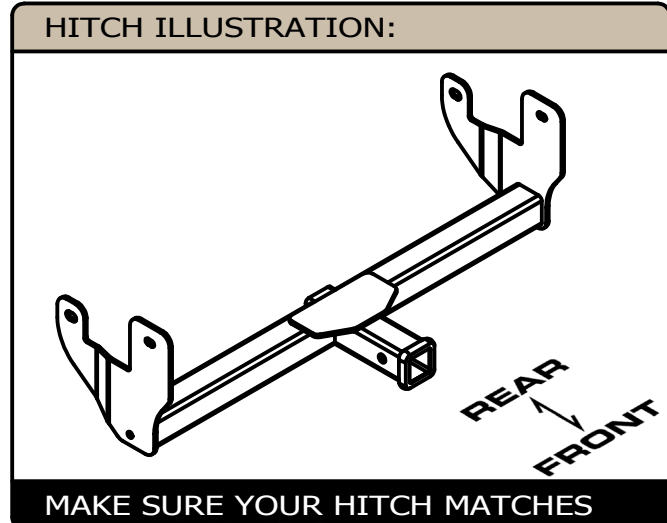
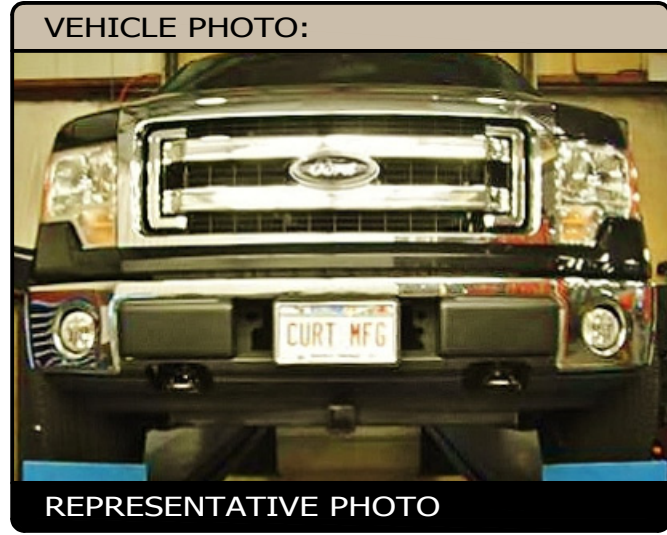

PERIODICALLY CHECK THIS RECEIVER HITCH TO ENSURE ALL FASTENERS ARE TIGHT AND ALL STRUCTURAL COMPONENTS ARE SOUND

CURT Manufacturing LLC. warrants this product to be free of defects in material and/or workmanship at the time of retail purchase by the original purchaser. If the product is found to be defective, Curt Manufacturing LLC. may repair or replace the product at their option, when the product is returned, prepaid, with proof of purchase. Alteration to, misuse of, or improper installation of this product voids the warranty. Curt Manufacturing LLC.'s liability is limited to repair or replacement of products found to be defective, and specifically excludes liability for incidental or consequential loss or damage.

INSTALLATION WALKTHROUGH:

Parts List			
ITEM	QTY	PART NUMBER	DESCRIPTION
1	2	HFN 1213, GR8	HEX FLANGE NUT
2	2	5/8-11	HEX FLANGE NUT
3	2	5/8-11 x 2, GR8	CARRIAGE BOLT
4	2	1_2 - 13 x 6 HEX	HEX BOLT
5	2	CM-SP16	.250 x 1.50 x 2.00" ROUND HOLE SPACER
6	2	FW12	FW, 12, ZP
7	2	5_8 FISHWIRE	5/8" FISHWIRE
8	2	31068-TS	3/4" x 11 GA TUBE SPACER

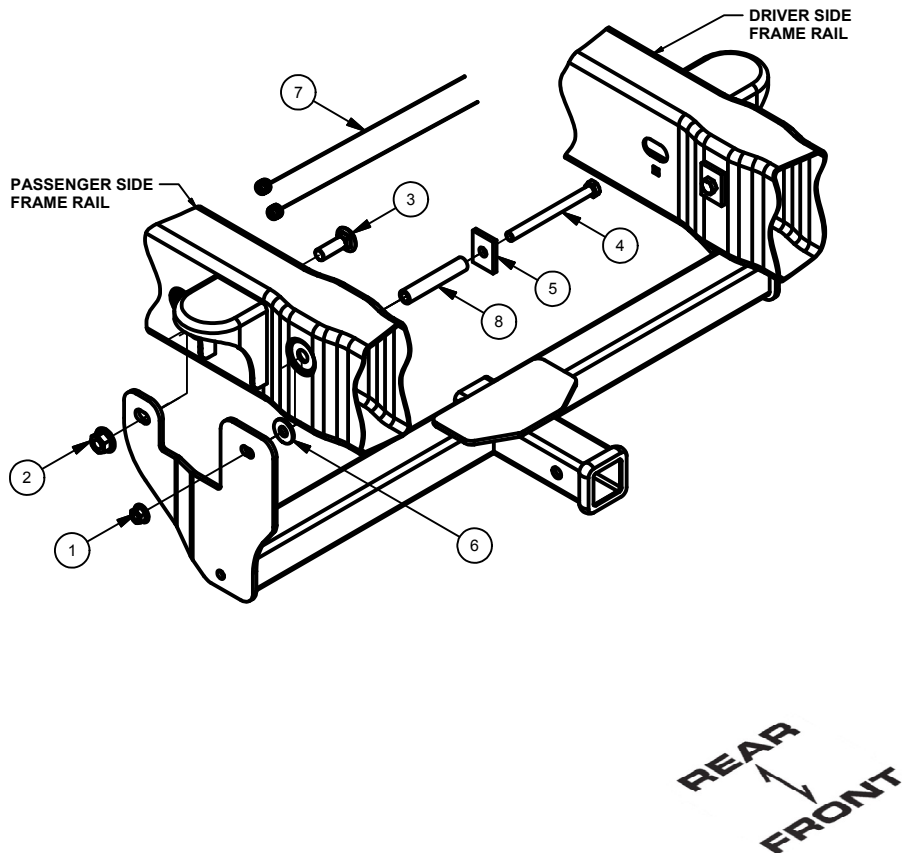

1. Remove the lower air dam on 2011 and newer trucks by removing (2) nuts with a 15MM socket. Trim the lower plastic bumper fascia as required using the diagram below as a reference only.

BUMPER FASCIA TRIM DIAGRAMS

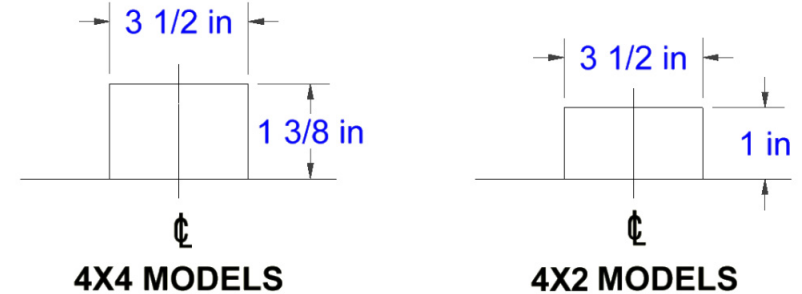

2. Tape the (2) 1/2" washers securely to the forward most attachment point. Insert 1/2" x 6" hex bolts into the CM-SP16 and 31068-TS and install from the inboard side of the frame through the 1" hole, passing out of the 1/2" washer.

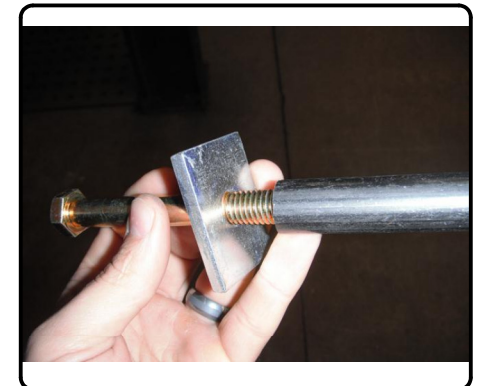
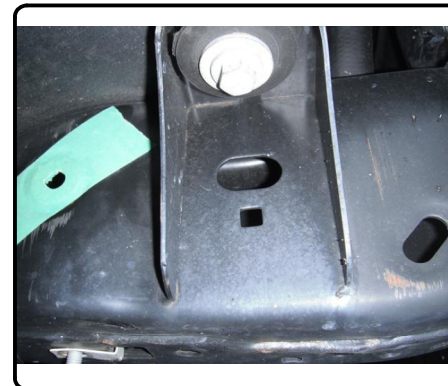

INSTALLATION WALKTHROUGH:

3. Press the 6" long bolts into the frame to allow the hitch to slide up into position. Raise hitch, press bolts back out, and loosely install the 1/2" hex flange nuts.

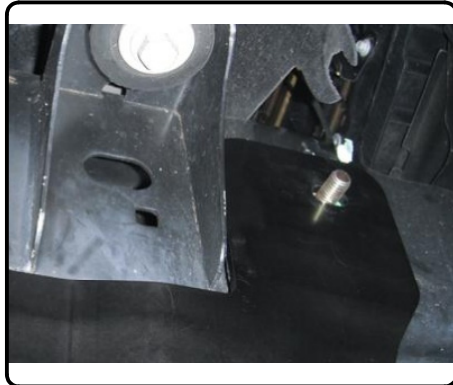

4. Fishwire the 5/8" carriage bolts from the end of the frame into the rearward mounting slots in the frame. Loosely install the remaining 5/8" hex flange nuts.

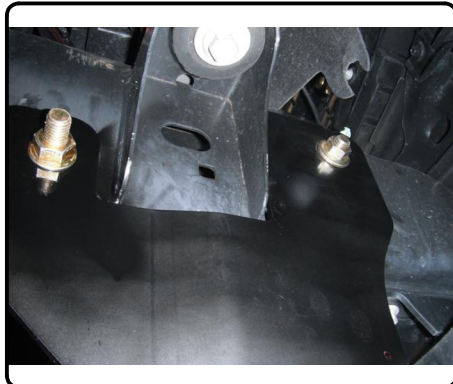

5. Torque all 1/2" fasteners to 110 lb-ft and all 5/8" fasteners to 210 lb-ft.

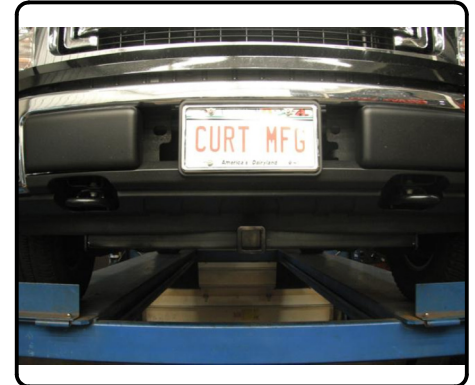
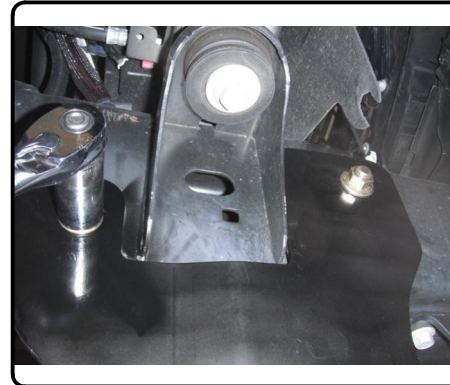

31068**FORD F-150****10/30/2013****GROSS LOAD CAPACITY WHEN USED AS A WEIGHT CARRYING HITCH: 5,000 LBS. TRAILER WEIGHT & 500 LBS. TONGUE WEIGHT.****GROSS LOAD CAPACITY WHEN USED AS A STRAIGHT LINE PULL: 9,000 LBS. MAX. LINE PULL.******* DO NOT EXCEED VEHICLE MANUFACTURER'S RECOMMENDED TOWING CAPACITY. *******HAVING INSTALLATION QUESTIONS? CALL TECHNICAL SUPPORT AT 1-800-798-0813**

Parts List			
ITEM	QTY	PART NUMBER	DESCRIPTION
1	2	HFN 1213, GR8	HEX FLANGE NUT
2	2	5/8-11	HEX FLANGE NUT
3	2	5/8-11 x 2, GR8	CARRIAGE BOLT
4	2	1_2 - 13 x 6 HEX	HEX BOLT
5	2	CM-SP16	.250 x 1.50 x 2.00" ROUND HOLE SPACER
6	2	FW12	FW, 12, ZP
7	2	5_8 FISHWIRE	5/8" FISHWIRE
8	2	31068-TS	3/4" x 11 GA TUBE SPACER

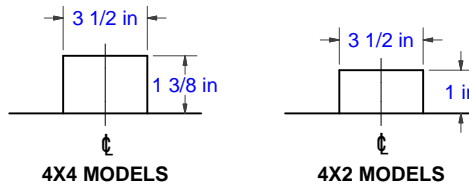
BUMPER FASCIA TRIM DIAGRAMS

FISHWIRE TECHNIQUE

INSERT COILED END OF FISHWIRE TOOL THROUGH HITCH MOUNTING HOLE IN VEHICLE FRAME RAIL AND OUT THE ACCESS HOLE. PASS COILED END OF FISHWIRE THROUGH SPACER AND THREAD BOLT INTO COIL. KINK WIRE TO KEEP SPACER SEPERATE FROM BOLT AS SHOWN. PULL FISHWIRE, SPACER, AND BOLT THROUGH FRAME AND OUT MOUNTING HOLE. USE FISHWIRE TO GUIDE HITCH DURING MOUNTING AND PREVENT LOSS OF BOLT / SPACER INSIDE FRAME RAIL.

NOTE: SOME VEHICLES MAY FISHWIRE THROUGH END OF FRAME

TOOLS REQUIRED
3/4" SOCKET
15/16" SOCKET
15MM SOCKET
RATCHET
TORQUE WRENCH
AVIATION SHEARS
TAPE
MARKER

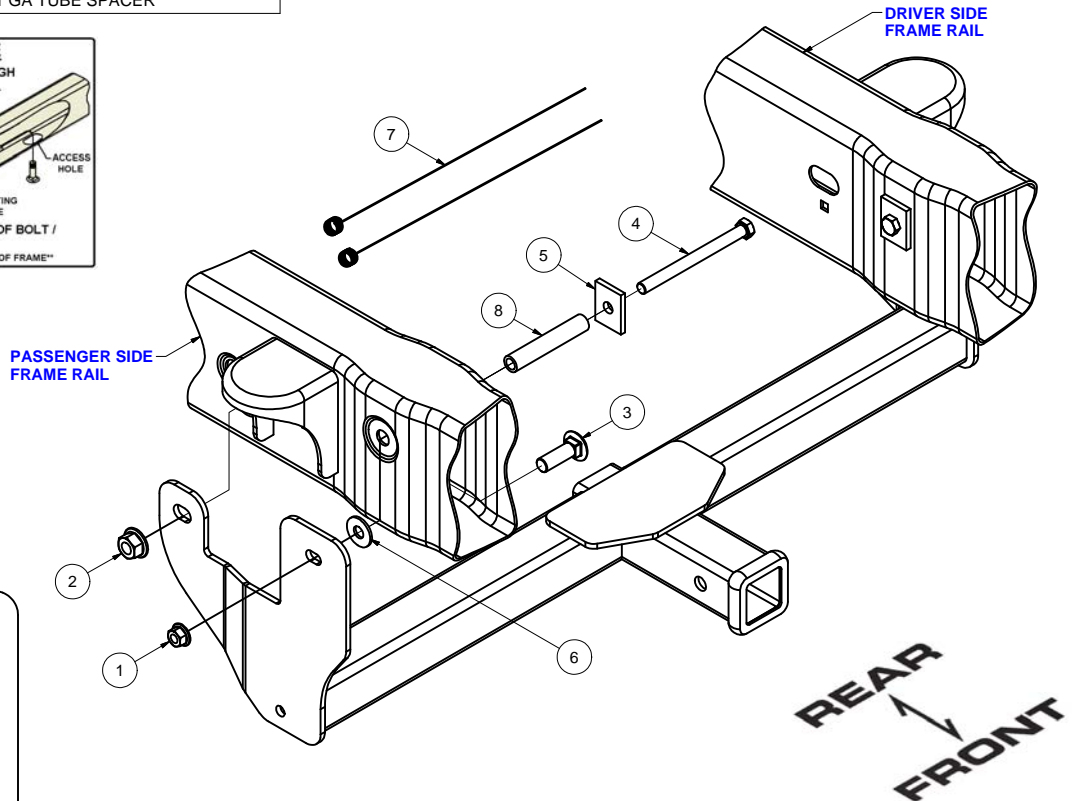
**HITCH WEIGHT: 37 LBS.****INSTALL TIME**

PROFESSIONAL: 30 MINUTES

NOVICE (DIY): 60 MINUTES

INSTALL NOTES:

- MAY NEED TO REMOVE AIR DAM
- TRIM LOWER BUMPER FASCIA
- FISHWIRING REQUIRED
- NO DRILLING

INSTALLATION STEPS

1. Remove the lower air dam on 2011 and newer trucks. Trim the lower plastic bumper fascia as required using the diagram above as a reference only.
2. Tape the (2) 1/2" washers securely to the forward most attachment point. Insert 1/2" x 6" hex bolts into the CM-SP16 and 31068-TS and install from the inboard side of the frame through the 1" hole, passing out of the 1/2" washer.
3. Press the 6" long bolts into the frame to allow the hitch to slide up into position. Raise hitch, press bolts back out, and loosely install the 1/2" hex flange nuts.
4. Fishwire the 5/8" carriage bolts into the rearward mounting slots in the frame. Loosely install the remaining 5/8" hex flange nuts.
5. Torque all 1/2" fasteners to 110 lb-ft and all 5/8" fasteners to 210 lb-ft.

PERIODICALLY CHECK THIS RECEIVER HITCH TO ENSURE THAT ALL FASTENERS ARE TIGHT AND THAT ALL STRUCTURAL COMPONENTS ARE SOUND.

Curt Manufacturing LLC., warrants this product to be free of defects in material and/or workmanship at the time of retail purchase by the original purchaser. If the product is found to be defective, Curt Manufacturing LLC., may repair or replace the product, at their option, when the product is returned, prepaid, with proof of purchase. Alteration to, misuse of, or improper installation of this product voids the warranty. Curt Manufacturing LLC.'s liability is limited to repair or replacement of products found to be defective, and specifically excludes liability for incidental or consequential loss or damage.

FORD F-150

*****DO NOT EXCEED VEHICLE MANUFACTURER'S RECOMMENDED TOWING CAPACITY ***.**

FRONT MOUNTED ACCESSORIES

1) Do not exceed front axle Gross Weight Rating (GAWR). Consult owners manual or specification plate located on driver's door frame. Measure gross front axle weight by placing front wheels of loaded vehicle on a scale.

WARNING: Exceeding GAWR may overload the front axle and/or suspension. This could result in **accident, property damage and personal injury.**

- 2) Reposition front mounted license plate if obstructed.
- 3) Do not obstruct vehicle lights.
- 4) Allow free air flow into grille opening.
- 5) Rear wheel traction may be reduced. This could effect handling. Reduce speed and drive with caution.
- 6) Accessories extend front of vehicle. This may reduce approach angle. Use caution when parking and maneuvering.
- 7) Do not obstruct driver view.

VEHICLE RECOVERY AND WINCHING TIPS

1) Use OEM tow hooks, recovery eyes or a clevis mount for attachment of a tow strap or winch cable.

WARNING: NEVER use a ball and/or ball mount as an anchor point for tow strap or winch cable. Severe personal injury or death could result.

- 2) Observe winch manufacturer's recommendations, cautions and warnings.
- 3) Attach return cable to tow hook or recovery eye when using a snatch block (See figure 1).

CAUTION: Do not attach return cable to winch mount. This may overload winch mount and/or front mounted receiver.

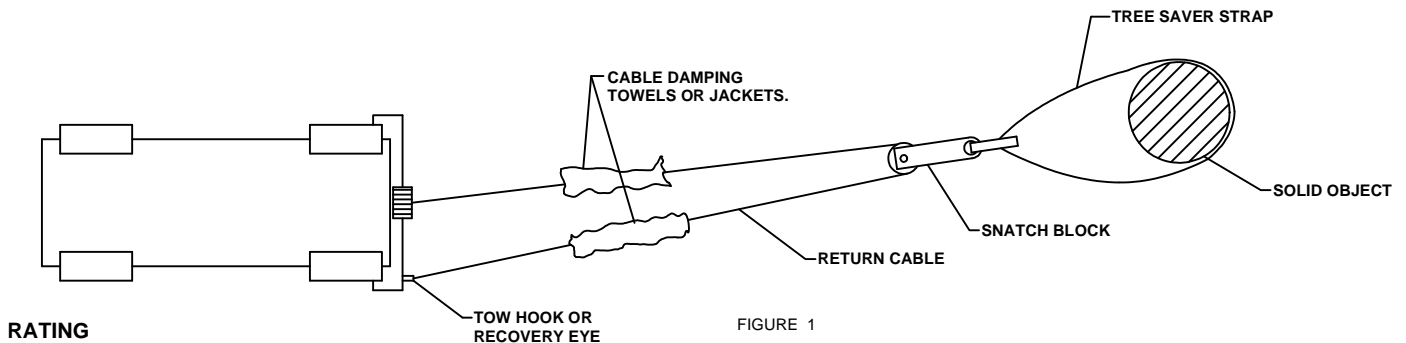

For **Maximum** line pull rating, winch cable must not exceed:
- 15 degree angle up or down from horizontal (See Figure 2).
- 45 degree angle left or right from straight ahead (See Figure 3).

CAUTION: Exceeding the maximum line pull rating may over load winch, winch mount, and/or front mounted receiver.

