

31221**CHEVROLET COLORADO / GMC CANYON**

9/2/2010

EXCLUDING Z71 MODELS WITH FRONT STABILIZER BAR

GROSS LOAD CAPACITY WHEN USED AS A WEIGHT CARRYING HITCH: 5000 LBS. TRAILER WEIGHT & 500 LBS. TONGUE WEIGHT.
GROSS LOAD CAPACITY WHEN USED AS STRAIGHT LINE PULL: 9000 LBS. MAX. LINE PULL.

DO NOT EXCEED VEHICLE MANUFACTURER'S RECOMMENDED TOWING CAPACITY.***

Parts List				
ITEM	QTY	PART NUMBER	DESCRIPTION	
1	1	1/2"	FISHWIRE TOOL	
2	2	1/2-13 x 1 3/4	CARRIAGE BOLT	
3	2	CM-SP3	.250 x 1.25 x 2.00" SQUARE HOLE SPACER	
4	2	HFN 1213	HEX FLANGE NUT	
5	2	3/4-10 x 4.00	HEX BOLT	
6	2	3_4 - 10 HFN	HEX FLANGE NUT	

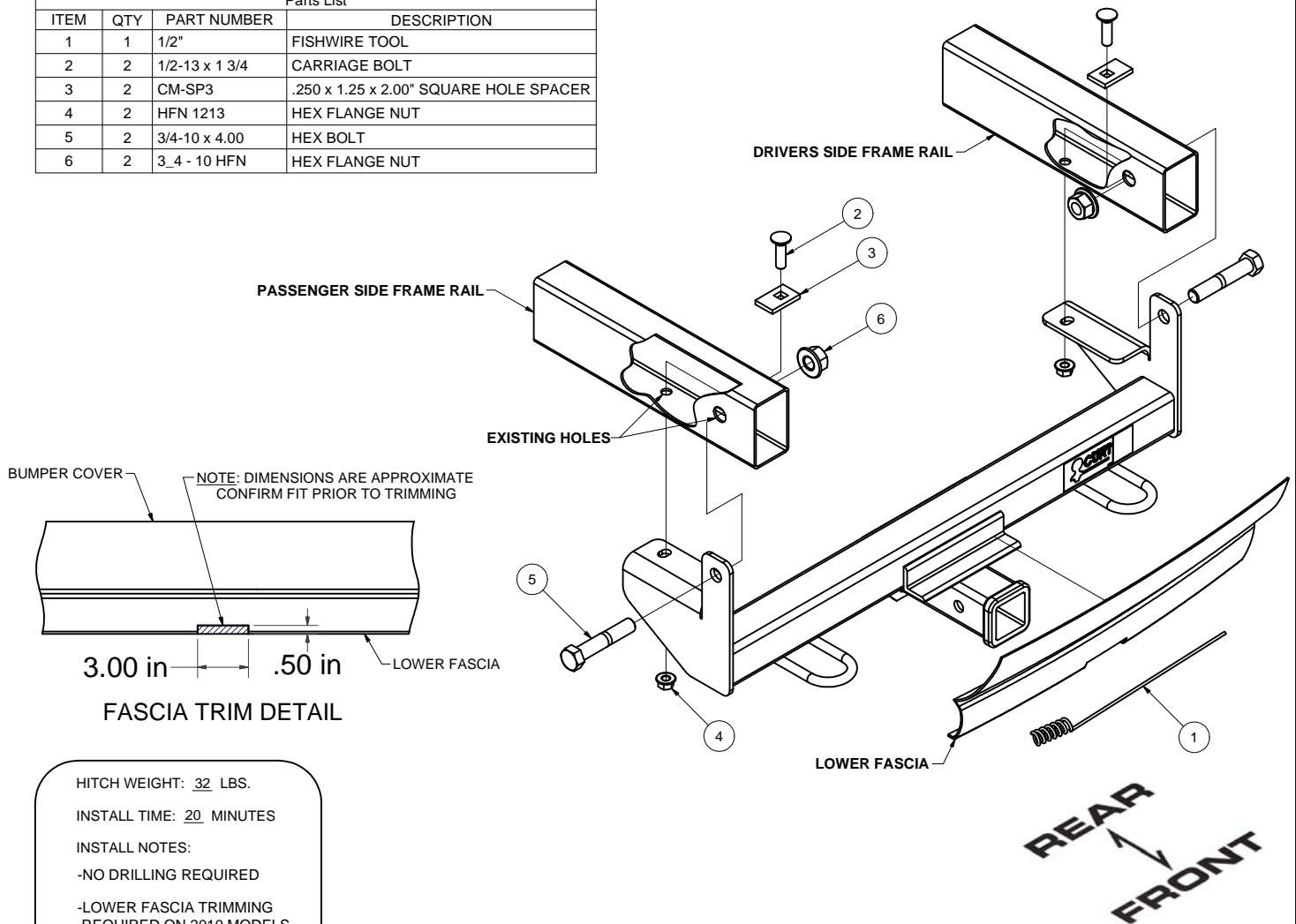
HITCH WEIGHT: 32 LBS.INSTALL TIME: 20 MINUTES

INSTALL NOTES:

-NO DRILLING REQUIRED

-LOWER FASCIA TRIMMING
REQUIRED ON 2010 MODELS**INSTALLATION STEPS**

- 1) Mark and trim lower fascia, or remove lower fascia and return to owner.
(See Fascia Trim Detail) (2010 models only)
- 2) Fishwire 1/2" carriage bolts and spacers through existing hole in side of frame rail and out existing hole in bottom of frame rail.
- 3) Lift hitch into position over 1/2" bolts and secure with flange nuts.
- 4) Install 3/4" bolts through hitch and frame and secure with flange nuts.
- 5) Torque all 1/2" fasteners to 75 lb-ft and all 3/4" fasteners to 260 lb-ft.

PERIODICALLY CHECK THIS RECEIVER HITCH TO ENSURE THAT ALL FASTENERS
ARE TIGHT AND THAT ALL STRUCTURAL COMPONENTS ARE SOUND.

Curt Manufacturing Inc., warrants this product to be free of defects in material and/or workmanship at the time of retail purchase by the original purchaser. If the product is found to be defective, Curt Manufacturing Inc., may repair or replace the product, at their option, when the product is returned, prepaid, with proof of purchase. Alteration to, misuse of, or improper installation of this product voids the warranty. Curt Manufacturing Inc.'s liability is limited to repair or replacement of products found to be defective, and specifically excludes liability for incidental or consequential loss or damage.