

INSTALLATION INSTRUCTIONS

EQUIPMENT REQUIRED CENTER PUNCH
 WIRING ACCESS LOCATION: PC3, PC4
 DRILL BITS: 1/8, 3/8, 1/2
 HITCH REQUIRES 1/2" PIN AND CLIP.
 WRENCHES: (TIGHTEN ALL FASTENERS WITH TORQUE WRENCH) 13mm, 15mm, 9/16, 11/16, 7/8

VEHICLE
 DODGE INTREPID
 EAGLE VISION
 CHRYSLER CONCORDE
 CHRYSLER NEW YORKER
 CHRYSLER LHS

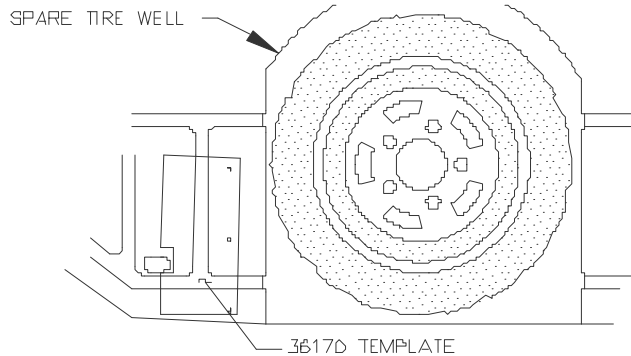

FIGURE 1. INSIDE TRUNK DRIVER'S SIDE

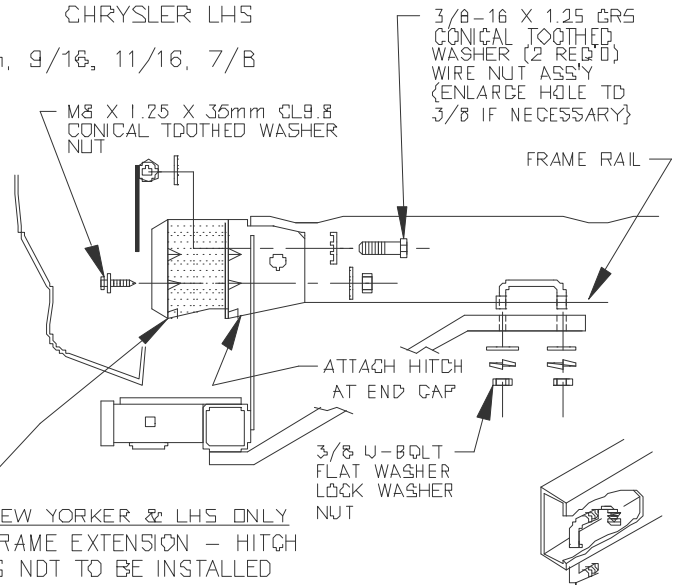

FIGURE 2. PASSENGER'S SIDE

NEW YORKER & LHS ONLY
 FRAME EXTENSION - HITCH IS NOT TO BE INSTALLED IN THIS AREA.

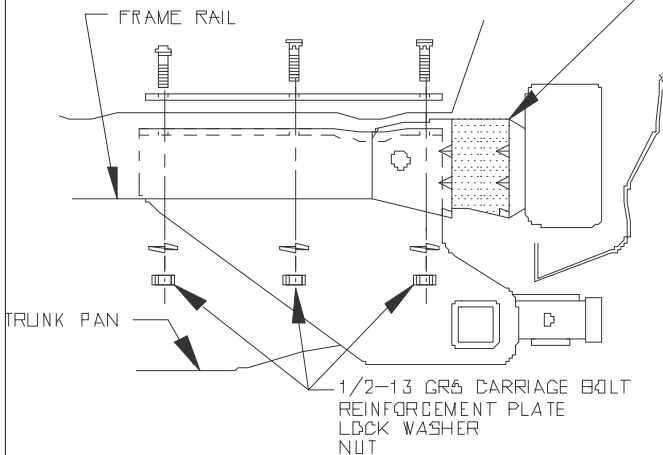

FIGURE 3. DRIVER'S SIDE

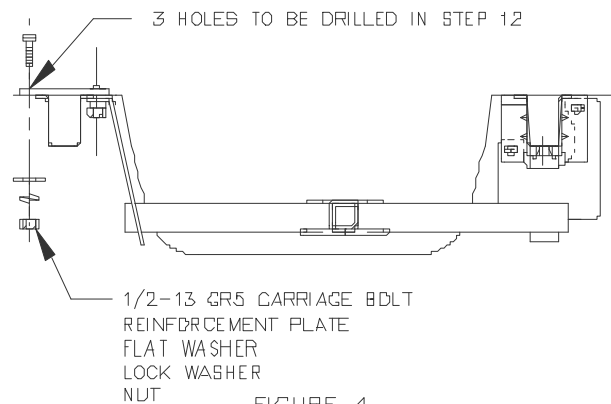

FIGURE 4.

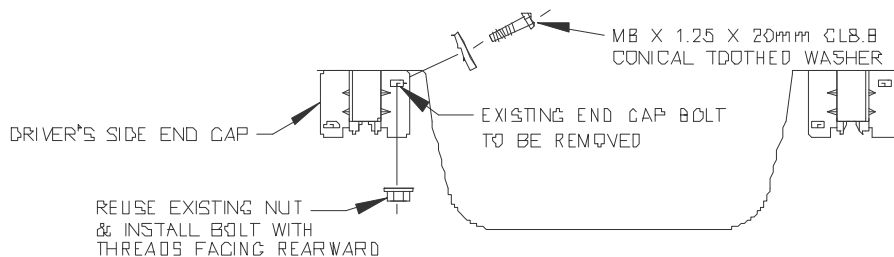

FIGURE 5.

*TIGHTEN U-BOLTS EVENLY WITH HAND TORQUE WRENCH. DO NOT USE IMPACT WRENCH.

THIS PRODUCT COMPLIES WITH SAFETY SPECIFICATIONS AND REQUIREMENTS FOR CONNECTING DEVICES AND TOWING SYSTEMS OF THE STATE OF NEW YORK, V.E.S.C. REGULATION V-3 AND SAE J684.

APPROX WEIGHT (LB.)	FASTENER KIT
38.5	01130-840

NOTE: Check hitch frequently, making sure all fasteners and ball are properly tightened. If hitch is removed, plug all holes in trunk pan or other body panels to prevent entry of water and exhaust fumes. A hitch or ball which has been damaged should be removed and replaced. Observe safety precautions when working beneath a vehicle and wear eye protection. Follow car maker's specs for maximum trailer weight and tongue weight. Do not cut excess or attachment holes with a torch.

TOWING PRODUCTS
 Plymouth, Michigan

VEHICLE

INSTALLATION INSTRUCTIONS

3500 LB MAX GROSS TRAILER WT
 300 LB MAX TONGUE WEIGHT
 DO NOT EXCEED TOWING VEHICLE RATINGS

1. REMOVE THE TWO (2) FASTENERS THAT ATTACH THE PASSENGER'S SIDE BUMPER BRACKET TO THE FRAME RAIL END CAP. RETURN FASTENERS TO VEHICLE OWNER.
2. REMOVE THE EXISTING DRIVER'S SIDE INBOARD FRAMERAIL END CAP BOLT AND REPLACE IT WITH FASTENERS AS SHOWN IN FIG 5 (TO PROVIDE ACCESS FOR CARRIAGE BOLTS INSTALLED IN STEP 12).
3. REMOVE SPARE TIRE COVER & PULL THE TRUNK CARPETING BACK TO EXPOSE THE DRIVER'S SIDE OF THE TRUNK PAN.
4. HOW TO USE THE "3617D TEMPLATE" (SHEET 3 OF INSTRUCTIONS):
 - * CUT TEMPLATE ALONG THE DOTTED LINES.
 - * PLACE TEMPLATE INSIDE TRUNK ON DRIVER'S SIDE OF SPARE TIRE WELL. SEE FIG 1.
 - * TEMPLATE SHOULD BE POSITIONED SO THAT THE ARROWS LINE UP WITH THE CENTERS OF THE RIBS IN THE TRUNK PAN.
 - * TAPE TEMPLATE IN PLACE ONCE THE ARROWS ARE LINED UP.
5. CENTER PUNCH THREE (3) PLACES AS SPECIFIED ON "3617D TEMPLATE." REMOVE TEMPLATE. DRILL THREE (3) 1/8" HOLES DOWN THROUGH TRUNK PAN AT CENTER PUNCHED LOCATIONS.

NOTE: YOU MAY WISH TO TRANSFER THE "3617D TEMPLATE" TO A STIFFER MATERIAL FOR USE ON FUTURE INSTALLATIONS.
6. LIFT THE HITCH INTO POSITION & LOOSELY FASTEN MB & 3/8" FASTENERS PROVIDED THROUGH PASSENGER SIDE END CAP.

NOTE: IF NECESSARY ENLARGE EXISTING HOLE IN VEHICLE END CAP FOR 3/8 FASTENER. (USE 3/8 DRILL BIT)
7. CHECK THE ALIGNMENT OF THE 1/8" DRILLED HOLES IN THE TRUNK PAN. MAKE ADJUSTMENTS AS NECESSARY AND ENLARGE HOLES TO 1/2"
8. USING THE HITCH AS A TEMPLATE MARK THE PASSENGER SIDE FRAME RAIL FOR DRILLING.
9. REMOVE THE HITCH AND DRILL TWO 1/2" DIAMETER HOLES THRU THE PASSENGER SIDE FRAME RAIL. INSTALL THE 3/8 U-BOLT IN THE PREVIOUSLY DRILLED HOLES. SEE FIG 2.
10. REINSTALL HITCH BEING CAREFUL NOT TO KNOCK THE U-BOLT INTO THE FRAME RAIL. LOOSELY INSTALL THE 3/8 WASHERS, LOCK WASHERS, NUTS, & MB FASTENERS PROVIDED.
11. POSITION REINFORCEMENT PLATE INSIDE TRUNK, ALIGNING THE NOTCH WITH THE SEALED DRAIN HOLE AND MAKING SURE THE THE HOLES IN THE PLATE LINE UP WITH THE HOLES ENLARGED IN STEP 7.
12. INSTALL 1/2" CARRIAGE BOLTS DOWN THRU REINFORCEMENT PLATE AND TRUNK PAN INTO HITCH. FASTEN WITH LOCK WASHERS AND NUTS AS SHOWN IN FIG 3.
13. USING REINFORCEMENT PLATE AS A TEMPLATE, DRILL THREE (3) 1/2" HOLES (OUTBOARD OF HOLES DRILLED EARLIER), THROUGH TRUNK PAN. INSTALL REMAINING 1/2 CARRIAGE BOLTS AND FASTEN WITH FLAT WASHERS, LOCK WASHERS AND NUTS.

NOTE: SEAL ALL HOLES DRILLED IN VEHICLE TO PREVENT ENTRY OF EXHAUST FUMES INTO TRUNK.

NOTE: IT MAYBE NECESSARY TO TEMPORARLY LOWER EXHAUST SYSTEM TO TIGHTEN 1/2 FASTENERS.

 - TIGHTEN 1/2-13 GR5 FASTENERS TO 75 LB.-FT.
 - TIGHTEN NUTS ON 3/8 U-BOLT TO 25 LB.-FT.
 - TIGHTEN 3/8-16 GR5 FASTENERS TO 31 LB.-FT.
 - TIGHTEN MB X 1.25 DL9.8 FASTENERS TO 25 LB.-FT.
 - TIGHTEN MB X 1.25 DL8.8 FASTENERS TO 20 LB.-FT.
14. REINSTALL CARPETING AND SPARE TIRE COVER IN TRUNK.

NOTE: REINFORCEMENT PLATE MUST BE INSTALLED AS DESCRIBED ABOVE TO INSURE SAFETY.



USE ONLY THE DRAWBAR SHOWN FOR CORRECT BUMPER CLEARANCE AND HEIGHT.
 DRAWBAR MUST BE USED IN THE RISE POSITION ONLY.

THIS PRODUCT COMPLIES WITH SAFETY SPECIFICATIONS AND REQUIREMENTS FOR CONNECTING DEVICES AND TOWING SYSTEMS OF THE STATE OF NEW YORK, V.E.S.C. REGULATION V-5 AND SAE J684.

APPROX WEIGHT (LB.)

NOTE: Check hitch frequently, making sure all fasteners and ball are properly tightened. If hitch is removed, plug all holes in trunk pan or other body panels to prevent entry of water and exhaust fumes. A hitch or ball which has been damaged should be removed and replaced. Observe safety precautions when working beneath a vehicle and wear eye protection. Follow car maker's specs for maximum trailer weight and tongue weight. Do not cut excess or attachment holes with a torch.

TOWING PRODUCTS
 Plymouth, Michigan

36170 TEMPLATE

