

INSTALLATION INSTRUCTIONS

VEHICLE
SUBARU LEGACY SEDAN
& WAGON (ALL MODELS)

3500 LB MAX GROSS TRAILER WT
300 LB MAX TONGUE WEIGHT
DO NOT EXCEED TOWING VEHICLE RATINGS

EQUIPMENT REQUIRED: TIN SNIPS
WIRING ACCESS LOCATION: PC3 & PC4
DRILL BITS: 1/2"
HITCH REQUIRES 1/2" PIN AND CLIP
WRENCHES: (TIGHTEN ALL FASTENERS WITH TORQUE WRENCH) 3/4, 7/8, M12

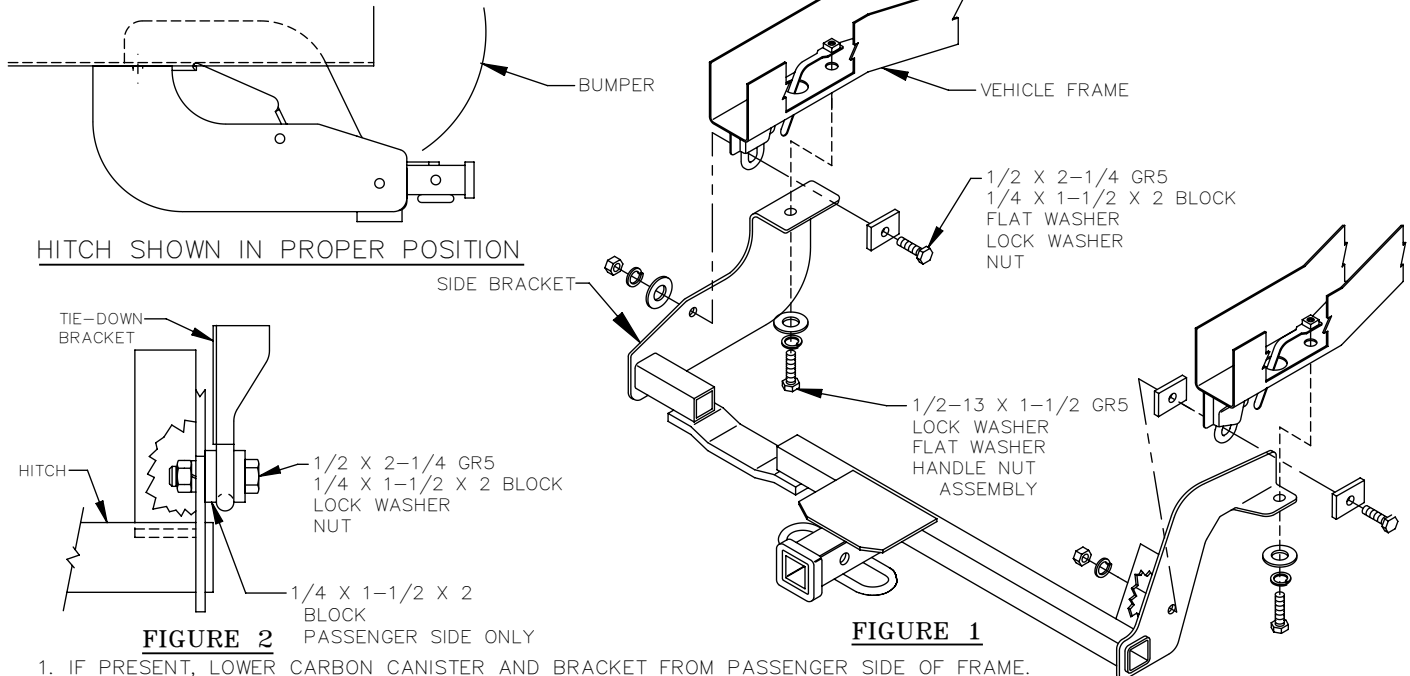

- FIGURE 2**
- IF PRESENT, LOWER CARBON CANISTER AND BRACKET FROM PASSENGER SIDE OF FRAME.
NOTE: FOR SUS SEDAN MODELS, IF PRESENT, REMOVE PLASTIC RIVET FROM BOTTOM CENTER OF FASCIA. BEND METAL REINFORCEMENT UP APPROXIMATELY 1/2".
 - POSITION HITCH ON VEHICLE AS SHOWN ABOVE IN FIGURE 1. ON SOME VEHICLES THE EXHAUST SHIELD (DRIVER'S SIDE) INTERFERES WITH THE HITCH. MARK AREA TO BE TRIMMED WHERE HITCH ATTACHES. REMOVE HITCH FROM VEHICLE AND TRIM HEAT SHIELD. REPOSITION HITCH ON VEHICLE.
NOTE: ON DRIVER'S SIDE, SIDE BRACKET ATTACHES TO THE OUTBOARD SIDE OF THE TIE-DOWN BRACKET. ON PASSENGER'S SIDE, SIDE BRACKET ATTACHES TO THE INBOARD SIDE OF THE TIE-DOWN BRACKET.
 - INSTALL 1/2 X 2-1/4 GR5 BOLT, 1/4 X 1-1/2 X 2 BLOCK THROUGH TIE-DOWN BRACKET, EACH SIDE. FASTEN WITH FLAT WASHER (DRIVER SIDE ONLY), LOCK WASHER AND NUT; SEE FIGURE 2 ABOVE.
NOTE: ON PASSENGER'S SIDE, PLACE ADDITIONAL BLOCK BETWEEN HITCH AND TIE-DOWN BRACKET.
 - USING HITCH AS A TEMPLATE, DRILL A 1/2" HOLE UP INTO BOTTOM OF FRAME THROUGH EACH SIDE.
 - USING ACCESS HOLE JUST REARWARD OF HITCH, INSERT HANDLE NUT ASSEMBLY INTO FRAME AS SHOWN IN FIGURE 1, EACH SIDE. INSTALL 1/2 X 1-1/2 GR5 BOLTS AND LOCK WASHERS UP THROUGH THE HITCH INTO THE HANDLE NUT ASSEMBLIES.
 - REATTACH CARBON CANISTER & BRACKET.
TIGHTEN 1/2 GR5 FASTENERS TO 75 LB.-FT.
TIGHTEN M8 FASTENERS TO 20 LB.-FT.

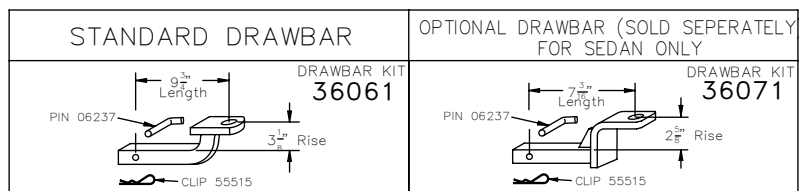

USE ONLY THE DRAWBAR SHOWN FOR CORRECT BUMPER CLEARANCE AND HEIGHT.
DRAWBAR MUST BE USED IN THE RISE POSITION ONLY.

THIS PRODUCT COMPLIES WITH SAFETY SPECIFICATIONS AND REQUIREMENTS FOR CONNECTING DEVICES AND TOWING SYSTEMS OF THE STATE OF NEW YORK, V.E.S.C. REGULATION V-5 AND SAE J684.

APPROX WEIGHT (LB.)	FASTENER KIT
35	1130-982

NOTE: Check hitch frequently, making sure all fasteners and ball are properly tightened. If hitch is removed, plug all holes in trunk pan or other body panels to prevent entry of water and exhaust fumes. A hitch or ball which has been damaged should be removed and replaced. Observe safety precautions when working beneath a vehicle and wear eye protection. Follow car maker's specs for maximum trailer weight and tongue weight. Do not cut access or attachment holes with a torch.

TOWING PRODUCTS
Plymouth, Michigan