

# INSTALLATION INSTRUCTIONS

VEHICLE

MERCURY VILLAGER  
NISSAN QUEST

EQUIPMENT REQUIRED: PHILLIPS HEAD SCREW DRIVER  
 WIRING ACCESS LOCATION: SUV1, SUV2  
 DRILL BITS: NONE  
 HITCH REQUIRES 1/2" PIN AND CLIP  
 WRENCHES: (TIGHTEN ALL FASTENERS WITH TORQUE WRENCH) 10mm, 19mm

3500 LB MAX GROSS TRAILER WT  
 300 LB MAX TONGUE WEIGHT  
 DO NOT EXCEED TOWING VEHICLE RATINGS

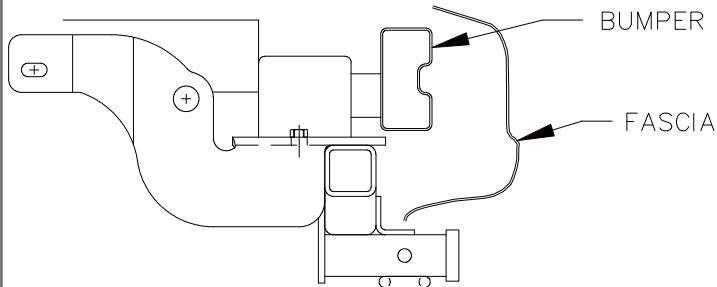

HITCH SHOWN IN PROPER POSITION

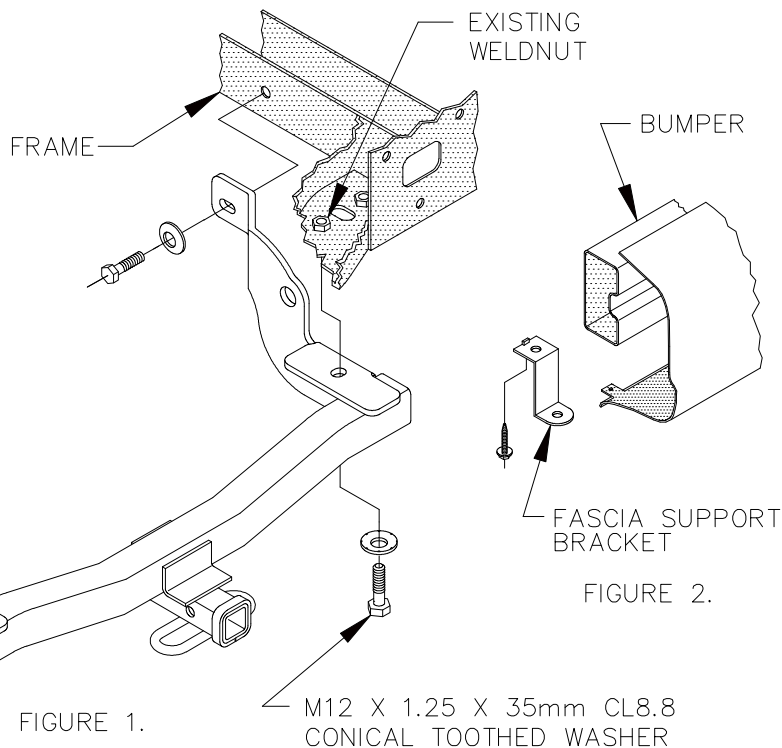
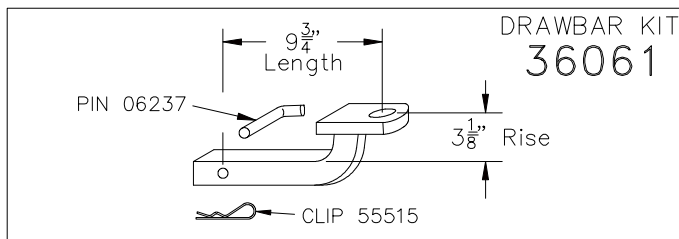

FIGURE 1.

FIGURE 2.

1. REMOVE THE (2) TWO FASCIA SUPPORT BRACKETS AND RETURN TO VEHICLE OWNER. (SEE FIGURE 2.)
2. LOWER VEHICLE EXHAUST.
3. RAISE HITCH INTO POSITION AND INSTALL FASTENERS AS SHOWN ABOVE. (SEE FIGURE 1.)
4. REATTACH VEHICLE EXHAUST LOWERED IN STEP 2.

TIGHTEN ALL M12 CL8.8 FASTENERS TO 68 LB.-FT



USE ONLY THE DRAWBAR SHOWN FOR CORRECT BUMPER CLEARANCE AND HEIGHT.  
 DRAWBAR MUST BE USED IN THE RISE POSITION ONLY.

THIS PRODUCT COMPLIES WITH SAFETY SPECIFICATIONS AND REQUIREMENTS FOR CONNECTING DEVICES AND TOWING SYSTEMS OF THE STATE OF NEW YORK, V.E.S.C. REGULATION V-5 AND SAE J684.

APPROX WEIGHT (LB.)	FASTENER KIT
27.5	F36277

NOTE: Check hitch frequently, making sure all fasteners and ball are properly tightened. If hitch is removed, plug all holes in trunk pan or other body panels to prevent entry of water and exhaust fumes. A hitch or ball which has been damaged should be removed and replaced. Observe safety precautions when working beneath a vehicle and wear eye protection. Follow car maker's specs for maximum trailer weight and tongue weight. Do not cut access or attachment holes with a torch.

**TOWING PRODUCTS**  
 Plymouth, Michigan