

**COVER PAGE**  
**56023 CUSTOM QUICK INSTALL MOUNTING KIT**  
**FOR GMC/Chevy -2500/3500**

**NOTE!**

Prior to installing product, please visit one of our websites to assure your kit contains the most recent revision to installation instruction and verify vehicle application.

***[www.ReeseProducts.com](http://www.ReeseProducts.com)***

**REMARQUE!**

Avant d'installer le produit, veuillez visiter un de nos sites Web pour vous assurer que votre ensemble contient la plus récente version des instructions d'installation et vérifier l'application qui convient à votre véhicule.

***[www.ReeseProducts.com](http://www.ReeseProducts.com)***

**NOTA!**

Antes de instalar el producto, por favor visite uno de nuestros sitios web para asegurar que su equipo contiene la revisión más reciente a instrucciones de instalación y verificar la aplicación del vehículo.

***[www.ReeseProducts.com](http://www.ReeseProducts.com)***

**FOR 30153 REESE® RAILS ONLY****GMC/Chevy 2500/3500 Pickup \*See website for applicable years & models****WARNING: FAILURE TO FOLLOW INSTALLATION INSTRUCTIONS MAY CAUSE PROPERTY LOSS, SERIOUS INJURY, OR DEATH!****CAUTION: Under no circumstances do we recommend exceeding the lower of towing vehicle manufacturers recommended vehicle towing capacity, or the lowest rated component of your system, or below:  
27,000 LB (12,247 Kg) Max Trailer Weight (GTW) and 5,400 LB (2,550 Kg) Max Tongue Weight (TW)****READ ALL INSTRUCTIONS BEFORE STARTING THE INSTALLATION OR USE****10 BOLT INSTALLATION ISR- KIT****IMPORTANT NOTE:** There are 3 vehicle frame configurations we are accommodating with this kit:

- 1) Vehicle frames without Helper Spring Brackets (see Fig. A, 1, & 4),
- 2) Vehicle frames with Helper Spring Brackets (see Fig. B, & 10), and
- 3) Vehicle frames without Helper Spring Brackets but threaded inserts inside, in area of front holes for forward brackets (see Fig. C below, details on page-9).

The truck frame without Helper Spring Brackets but threaded inserts inside (configuration -3) will require additional fasteners that are not provided with this kit.

Details of additional fasteners: Four GM Bolts- p/n 11589278 that can be purchased from a local GM dealer or equivalent flanged hex M12X1.75X (70-75 mm length) Gr. 10.9 bolts. If Gr. 10.9 hex bolts are used in place of flanged hex bolts, then it requires an M12 or ½” conical washers or flat washer + lock washer.

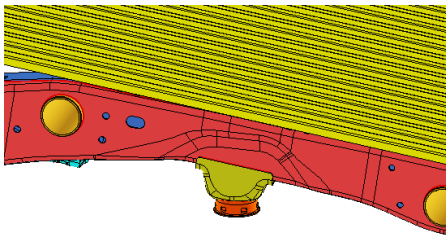

Figure A: config. 1

Truck frame without  
Helper Spring Brackets

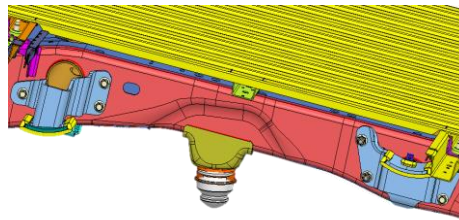

Figure B: config. 2

Truck frame with Helper  
Spring Brackets

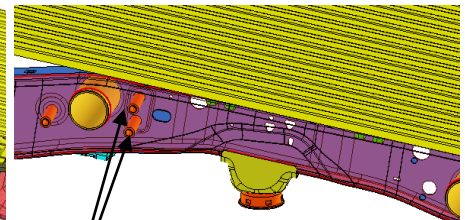

Figure C: config. 3

Truck frame without Helper  
Spring Brackets but threaded  
inserts inside

**WARNING: FAILURE TO FOLLOW INSTALLATION INSTRUCTIONS MAY CAUSE PROPERTY LOSS, SERIOUS INJURY, OR DEATH!**

**CAUTION: Under no circumstances do we recommend exceeding the lower of towing vehicle manufacturers recommended vehicle towing capacity, or the lowest rated component of your system, or below: 27,000 LB (12,247 Kg) Max Trailer Weight (GTW) and 5,400 LB (2,550 Kg) Max Tongue Weight (TW)**

**Equipment Required:**

**Fastener Kit:** 56023F

**Wrenches:** 3/4", 13mm, 18mm

**Drill Bits:** 1/8", 9/16"

**Other Tools:** Center Punch, Measuring Tape  
Torque Wrench

Any hardware shown in Figure 1, but not described in table below are supplied with 30153 kit.

**Note:** Truck frame without helper spring brackets but threaded inserts inside require additional bolts as mentioned in page-2.

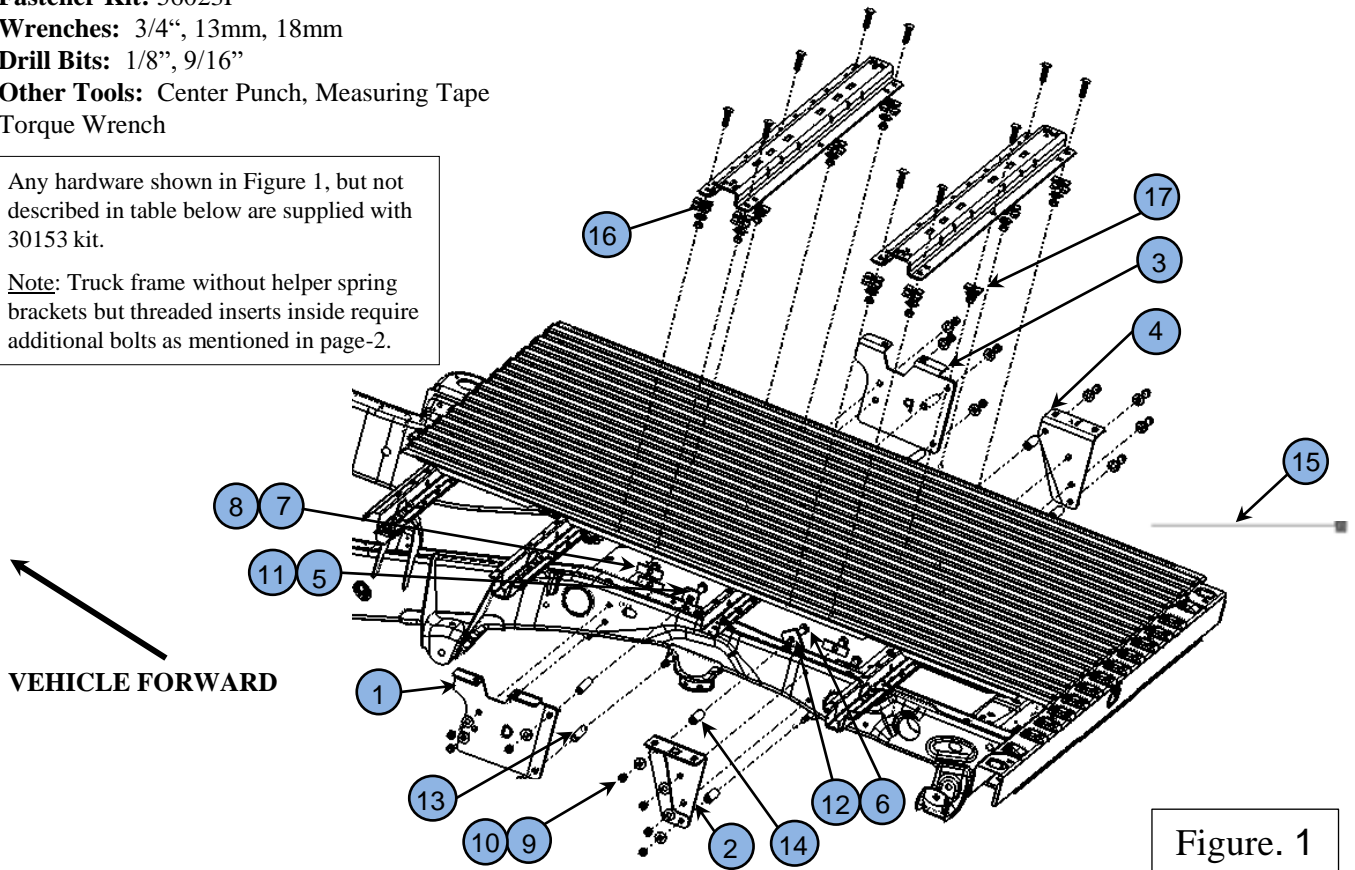

Figure. 1

#	Description	QTY	#	Description	QTY
1	Driver Side Front Frame Bracket	1	10	Nut , 1/2"-13 GR8	16
2	Driver Side Rear Frame Bracket	1	11	Carriage Bolt , 1/2"-13x5.5" GR8	4
3	Passenger Side Front Frame Bracket	1	12	Carriage Bolt, 1/2"-13x4.5" GR8	4
4	Passenger Side Rear Frame Bracket	1	13	Tube Spacer, 1/2"x3.5	4
5	Block-Inside Frame Front Mounting	2	14	Tube Spacer, 1/2"x2.5	4
6	Block-Inside Frame Rear Mounting	2	15	Pull Wire, 1/2"	8
7	Carriage Bolt, 1/2"-13x1.75" GR8	8	16	U-Shaped Block , 1/4"x1"x2"	8
8	Block - 1/4"x1"x3"	8	17	Block - 1/4"x1"x2"	8
9	Conical Washer-1/2"	18			

- **Do not install mounting rails over plastic bed liners. Plastic bed liners must be cut out of the way to provide metal to metal contact. Mounting rails may be installed on spray in liners.**
- **Use only bolts, nuts, and washers supplied to install this kit. All bolts and nuts are Grade 8 unless otherwise specified.**
- **These instructions are guidelines only, actual installation is the responsibility of the installer and the owner. Always measure truck and trailer before installing hitch to be sure that there is clearance at the cab and at the bumper to allow for turns.**
- **Do not install this product on or attempt to tow with a truck with a 5-1/2' bed unless a sidewinder pin box coupler has been installed on the trailer.**

1. Place the front mounting rail in the bed of the truck. Using a tape measure, center the rail on the floor of the truck bed and locate the proper distance from the rear of the rail to the back edge of truck bed as illustrated on figure (3). Choose the correct dimensions from figure (3) per Standard/Long truck bed.
2. Use a center punch to mark holes in the bed per the illustration. Move the rail out of the way and drill each position with a 1/8" drill bit. **CAUTION: When drilling holes through the bed be sure what is below the truck bed in those locations.**
3. Loosely install the Front frame brackets (1) and (3) using appropriate hardware and hand tighten. (See figures 1, 4, 7) **NOTE: If the truck has helper spring brackets / no helper spring brackets but threaded inserts inside of the frame, refer to additional instructions on page-9 for installing frame brackets.**

**DRIVER FRONT BRACKET (1):**

A. Using two 1/2" fishwires (15) provided, install two 1/2" x 1.75 carriage bolts (7) and 1"x3" blocks (8) using slot (Inside frame holes on Driver side are blocked by fuel tank and are not accessible) on outside of the frame. Run the fishwire going in from this slot and come out of the bolt holes as shown in figure (4). Keep both fishwires on the bolt until the bracket is installed. Place the conical washer (9) on the carriage bolt and secure with nut (10).

B. Now position the Front mounting block (5) on driver side against inside of the frame. While positioning front mounting block, the brake line bracket will be in the way. Loosen the two-brake line support bracket bolts (M8) as shown in figure (5), creating enough space for mounting block to pass through, until closely aligning mounting block slots with frame bracket holes. Now install two 1/2" x 5.5 carriage bolts (11) running from inside of frame through mounting block, 1/2"x3.5 Tube Spacer (13) and frame bracket as shown in figures (1 & 4). Place the conical washer on the carriage bolt and secure with the nut. Fasten the brake line bracket bolts.

**PASSENGER FRONT BRACKET (3):**

C. Following the similar procedure as on the driver's side, using two 1/2" fishwires provided, install two 1/2" x 1.75 carriage bolts (7) and 1"x3" blocks (8) using larger top hole on inside of frame as shown in figure (8). Run the fishwire from this hole and coming out of the carriage bolt hole. Place the conical washer and secure with the nut.

D. Now position the front mounting block on passenger side (5) against inside of the frame aligning slots with frame bracket holes. Install two 1/2" x 5.5 carriage bolts (11) running from inside of frame through mounting block, 1/2"x3.5 Tube Spacer (13) and frame bracket as shown in figures (1 & 7). Place the conical washer on the carriage bolt and secure with the nut.

4. **STOP! and** Check the 1/8" holes drilled in step 2 align with the frame bracket holes. If holes do not align, restart the installation at step 2 by adjusting 1/8" holes in bed of truck. When holes align with the brackets, remove the brackets and enlarge all the 1/8" holes for forward rail in the bed to 9/16" for 1/2" carriage bolts.

5. Replace the mounting frame brackets as described in step 3.
6. Reposition the front mount rail over the enlarged holes. Install the front rail using carriage bolts supplied in 30153 kit. Ensure 5/16" U-shaped spacer supplied in 30153 kit and 1/4" U-shaped spacer supplied in 56023 kit are installed as shown in figures (2.a and 2.b). Attach the 1/2" conical washers and hex nuts on bottom side of the frame brackets (1) and (3). Install center bolt using the supplied 1"x2" block (17) on bottom side of bed floor. Hand tighten all fasteners.
7. **NOTE:** If the truck has helper spring brackets, refer to additional instructions on page-9 for installing frame brackets.
8. Loosely install the Rear frame brackets (2) and (4) using appropriate hardware and hand tighten. (See figures 1,4,7)  
**DRIVER REAR BRACKET (2):**
  - A. Using two 1/2" fishwires provided, install two 1/2" x 1.75 carriage bolts (7) and 1"x3" blocks (8) using larger top hole on inside of frame as shown in the figure (6). Run the fishwire from this hole and come out of the bolt holes. Place the conical washer (9) on the carriage bolt and secure with nut (10).
  - B. Now position the rear mounting block (6) against inside of the frame. Rear mounting blocks will be tilted in position. While positioning rear mounting block, wire harness will be coming in the way. Remove the wire harness retainers (tree style) with appropriate tool from the frame as shown in figure (6). Now install two 1/2" x 4.5 carriage bolts (12) running from inside of frame through rear mounting block, 1/2"x2.5 Tube Spacer (14) and frame bracket as shown in figure (7). Place the conical washer on the carriage bolt and secure with the nut.**PASSENGER REAR BRACKET (4):**
  - C. Following the similar procedure as on the driver's side, using two 1/2" fishwires provided, install two 1/2" x 1.75 carriage bolts (7) and 1"x3" blocks (8) using larger top hole on inside of frame as shown in the figure (9). Run the fishwire from this hole and come out of the carriage bolt hole. Place the conical washer and secure with the nut.
  - D. Position the rear mounting block (6) against inside of the frame aligning slots with frame bracket holes. Now install two 1/2" x 4.5 carriage bolts (12) running from inside of frame through the mounting block, 1/2"x2.5 Tube Spacer (14) and frame bracket as shown in figure (7). Place the conical washer on the carriage bolt and secure with the nut.
9. Place the unassembled 5th wheel support arches/slider/goose into the already installed front mounting rail. Position the rearward mounting rail with the support arches/slider/goose by inserting the tabs into the mounting rail and pushing the mounting rail tight towards the other mounting rail. Ensure that the mounting rail is centered on the bed of the vehicle. This will position the rail in the correct location and ensure that the 5th wheel will have a snug fit to the truck. Note: If more than one hitch product will be used with the mounting rails both types should be used at the same time to align the mounting rails. This will ensure that one product does not compromise the fit of the other.
10. Mark and center punch the holes in rear mounting rail as per figure (3). Move the rear rail out of the way and drill with a 1/8" drill bit. **CAUTION: When drilling holes through the bed be sure what is below the truck bed in those locations.**
11. Follow steps 4, 5, 6 from the front mounting rail and install rear mounting rail.
12. Hardware: Tighten first REESE bed rails to mounting brackets and then mounting brackets to truck frame. Torque all 1/2" Gr. 8 hardware to 110 ft-lbs. (149 N\*M) and M12 Gr. 10.9 bolts to 90 ft-lbs. (122 N\*M)

#### FOR 30153 REESE® RAILS ONLY

GMC/Chevy 2500/3500 Pickup \*See website for applicable years & models

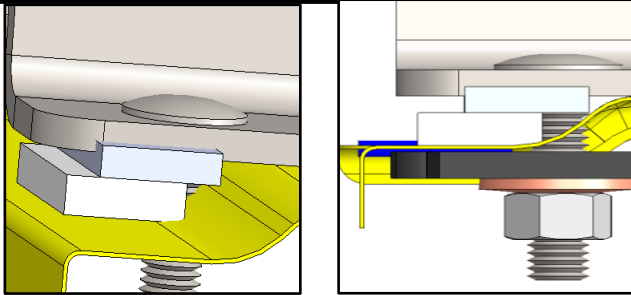
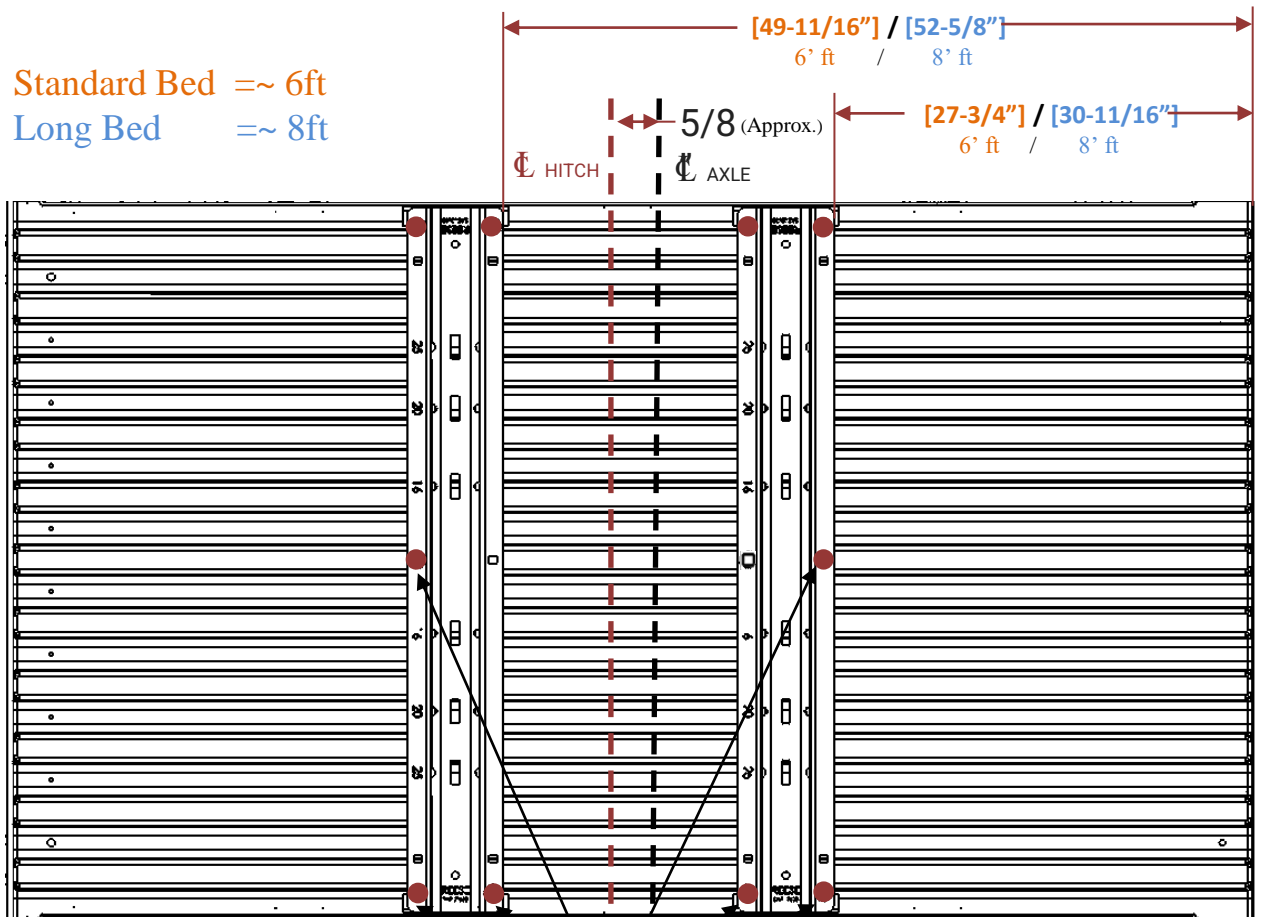

Figure 2.a

Figure 2.b

- Overlap the spacers as shown to overcome bed corrugation transitions and better contact.
- Total thickness of spacers  $5/16'' + 1/4''$  is slightly greater than the bed corrugation height. Meaning the rails may not sit flat on the bed corrugation. This is allowable.

Standard Bed  $\approx 6\text{ft}$   
Long Bed  $\approx 8\text{ft}$



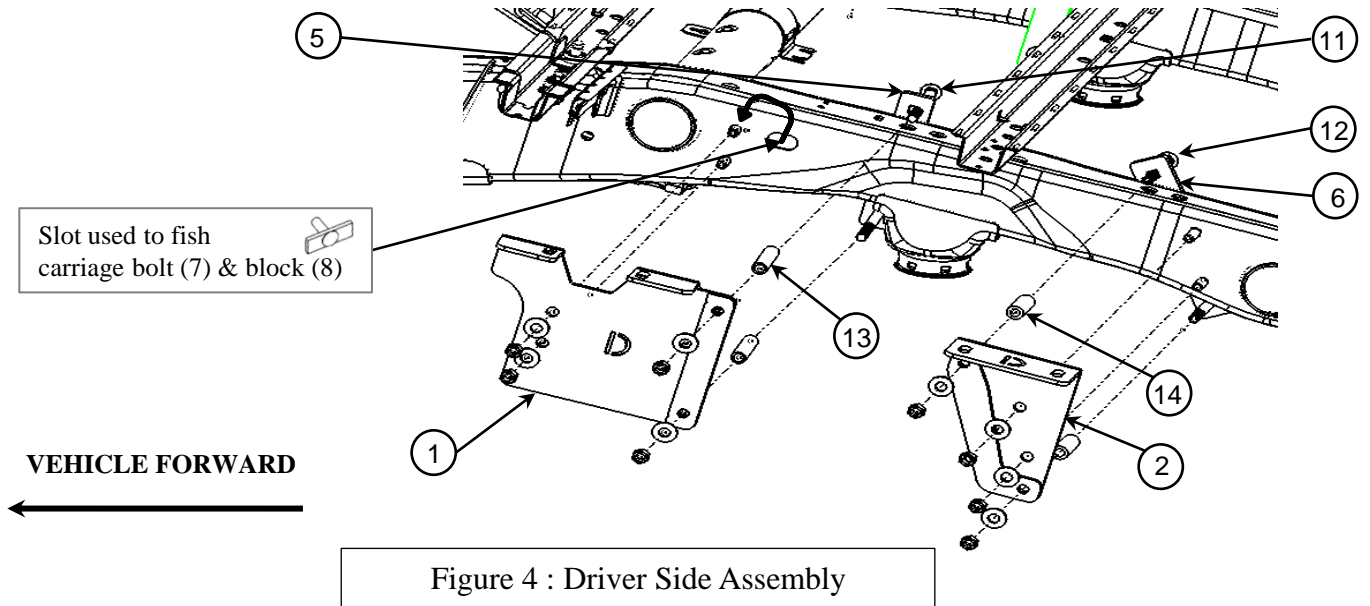

Figure 5: Driver Side Front

Loosen the 2-brake line support bracket bolts (M8), creating space for mounting block to pass through.

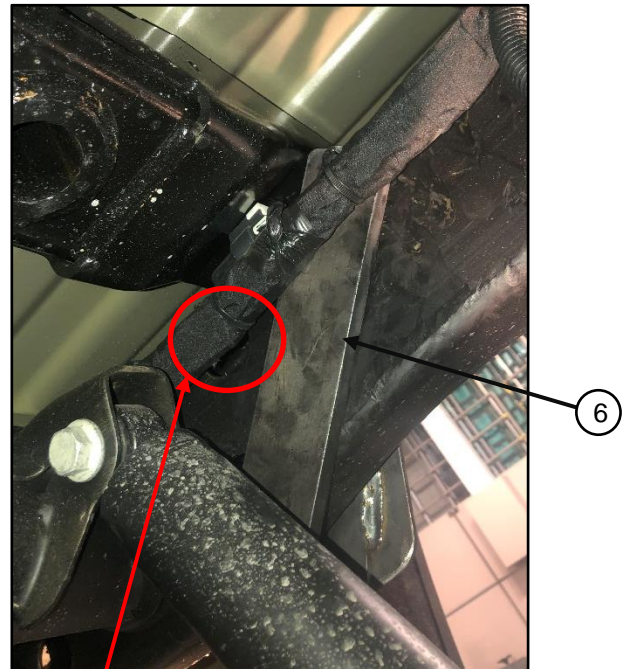
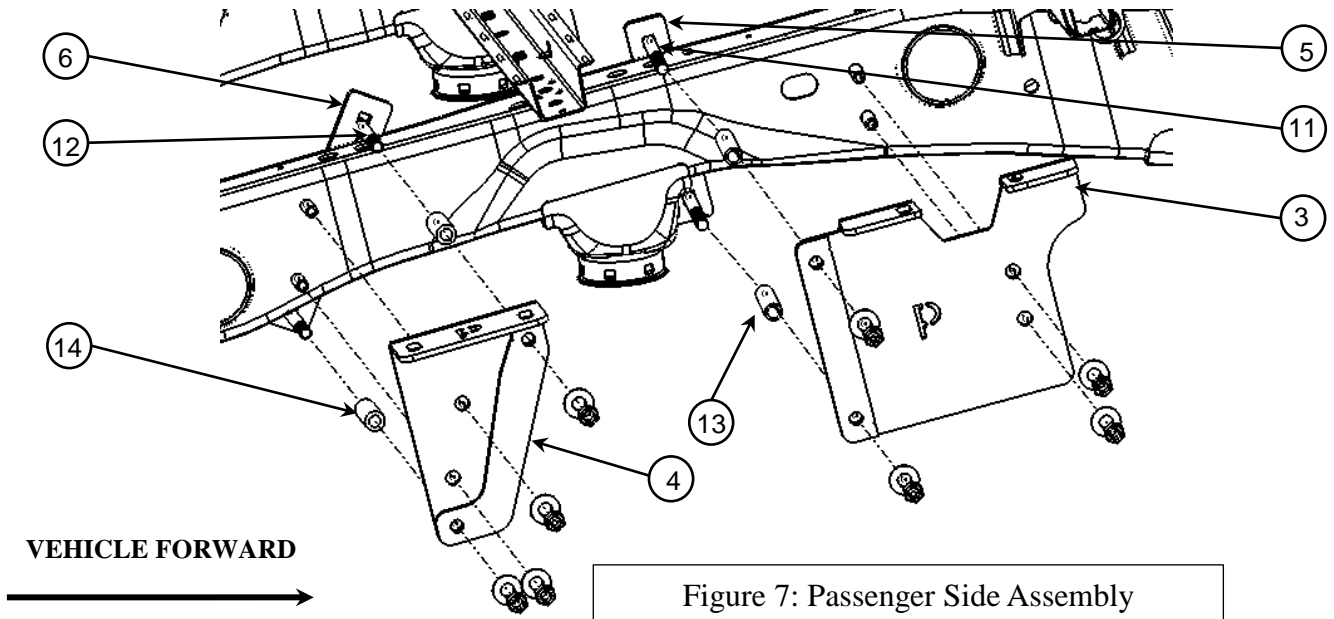

Figure 6: Driver Side Rear

Remove the harness retainers from the frame and use the hole behind harness as shown for fishing fasteners (7) & (8).



**Figure 8: Passenger Side Front**  
Use the hole shown above for fishing Carriage bolt (7) and block (8).



**Figure 9: Passenger Side Rear**  
Use the larger top hole shown above for fishing Carriage bolt (7) and block (8).

**Additional installation instructions for truck configurations 2 and 3.**

VEHICLE FORWARD

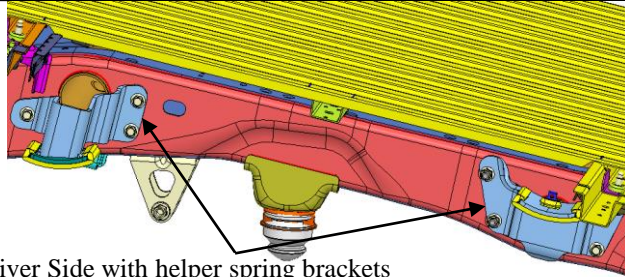

Figure 10: Driver Side with helper spring brackets

Front Side – Driver and Passenger Frame Brackets:

- A. Remove the front helper spring brackets on both driver and passenger side by removing M12 bolts. Then follow steps 3 to 6, but in step 3.A and 3.C, after positioning front frame bracket, place the front helper spring bracket removed earlier back on top of it and re-install the factory M12 bolts, (Attach a spacer block-1"x2" (17) for front bolt ) to secure from outside. Refer to figures (11 and 13). If the truck has NO helper spring brackets but threaded inserts inside of the frame, then it may need four GM Bolts- p/n 11589278 that can be purchased from a local GM dealer or equivalent flanged hex M12X1.75X (70-75 mm length) Gr. 10.9 bolts. If Gr. 10.9 hex bolts are used in place of flanged hex bolts, then it requires an M12 or ½" conical washers or flat washer + lock washer. CAUTION: If 11589278 GM bolts are NOT used to secure brackets then pay close attention while tightening as the fuel tank is close to the inside of the truck frame.

Rear Side – Driver and Passenger Frame Brackets:

- A. Remove the rear helper spring brackets on both driver and passenger side by removing M12 bolts. Then follow steps 7 to 11, but in step 7.A and 7.C, fish the carriage bolts (7) and blocks (8) first from inside at 4 places as shown in figures (12 and 13). Place two spacer blocks -1"x2" (17) on rear two bolts and then place frame brackets followed by helper spring bracket removed earlier passing through carriage bolts (7) as shown in figures (12 & 13). Place conical washer (9) and secure with nut (10) or re-install the factory M12 bolts removed earlier. (Attach a spacer block-1"x2" (17) for rear bolts) Refer to figures (12 and 13).

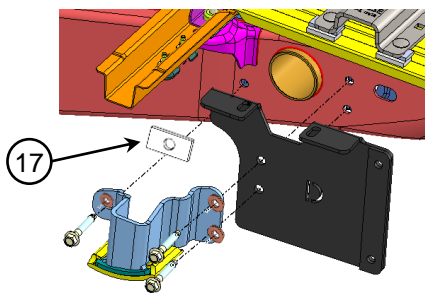

Figure 11: Front Assembly

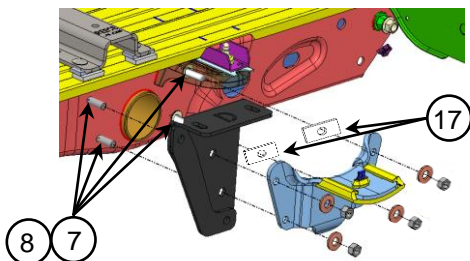
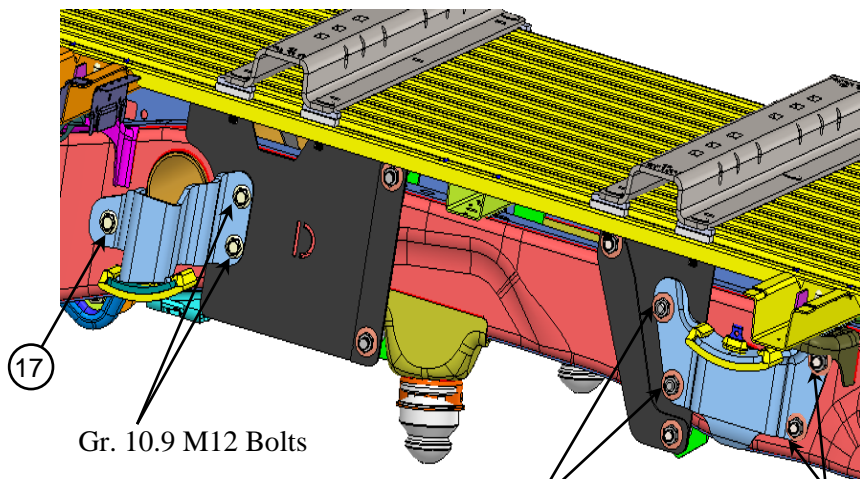

Figure 12: Rear Assembly



Gr. 10.9 M12 Bolts

Figure 13: Driver Side Assembly

(9) Fishing required on  
(10) 4-bolts from inside

(9)  
(10)  
(17)



# Installation Instructions

**Part Number:**

**REESE® CUSTOM QUICK INSTALL MOUNTING KIT**

**56023**

**FOR 30153 REESE® RAILS ONLY**

**GMC/Chevy 2500/3500 Pickup \*See website for applicable years & models**

## LIMITED LIFETIME WARRANTY

Horizon Global Corporation. (“We” or “Us”) warrants to the original consumer purchaser only (“You”) that the product will be free from material defects in both material and workmanship, ordinary wear and tear expected; provided that installation and use of the product is in accordance with product instructions. There are no other warranties, express or implied, including the warranty of merchantability or fitness for a particular purpose. This warranty is not transferable.

This warranty does not cover: (a) normal wear and tear; (b) damage through abuse, neglect, misuse, or as a result of any accident or in any other manner; (c) damage from misapplication, overloading, or improper installation; (d) improper maintenance and repair; and (e) product alteration in any manner by anyone other than Us, with the sole exception of alterations made pursuant to product instructions and in a workmanlike manner.

To make a Warranty claim, contact Us, at our principal address of 47912 Halyard Dr. Suite 100, Plymouth, MI 48170, 1-800-632-3290, identify the product by model number, and follow the claim instructions that will be provided. Any returned product that is replaced by Us becomes our property. You will be responsible for return shipping costs. Please retain your purchase receipt to verify date of purchase and that You are the original consumer purchaser. The product and the purchase receipt must be provided to Us in order to process Your Warranty claim.

Product replacement is your sole remedy under this Warranty. We shall not be liable for service or labor charges incurred in removing or replacing a product or any incidental or consequential damages of any kind.

You acknowledge and agree that any use of the product for any purpose other than the specified use(s) stated in the product instructions is at Your own risk.

This Warranty gives you specific legal rights, and You may also have other rights which vary from state to state. This Warranty is governed by the laws of the State of Michigan, without regard to rules pertaining to conflicts of law. The state courts located in Oakland County, Michigan shall have exclusive jurisdiction for any disputes relating to this warranty.

**For the most up to date product  
instructions, installation and use  
information please scan the QR  
code or call  
1-800-632-3290**



Horizon Global  
47912 Halyard Dr. Suite 100  
Plymouth, MI 48170