

# **LoadLIFTER** **5000** by AIR LIFT®

**Kit 57291**  
**1999-2007**  
**Ford F-250/F-350**  
**2 & 4WD**



## **INSTALLATION GUIDE**

For maximum effectiveness and safety, please read these instructions completely before proceeding with installation.

*Failure to read these instructions can result in an incorrect installation.*



# TABLE OF CONTENTS

<b>Introduction</b> .....	<b>2</b>
Important Safety Notice .....	2
Notation Explanation .....	2
<b>Installation Diagram</b> .....	<b>3</b>
Hardware List .....	3
Tools List .....	4
<b>Installing the LoadLifter5000 System</b> .....	<b>4</b>
Getting Started .....	4
Special Applications Instructions .....	4
Assembling the Air Spring Unit .....	5
Removing the Passenger Side Shock Bracket Rivet .....	6
Attaching the Lower Bracket .....	6
Attaching the Upper Bracket .....	6
Securing the Air Spring to the Brackets .....	6
Installing the Air Lines .....	7
Securing the Emergency Brake Cable .....	8
Checking for Leaks .....	8
Fixing Leaks .....	8
<b>Before Operating</b> .....	<b>9</b>
Installation Checklist .....	9
Post-Installation Checklist .....	9
<b>Product Use, Maintenance and Servicing</b> .....	<b>10</b>
Minimum and Maximum Pressure .....	10
Maintenance Guidelines .....	10
Troubleshooting Guide .....	10
Frequently Asked Questions .....	10
Tuning the Air Pressure .....	11
Guidelines for Adding Air .....	11
<b>Warranty and Returns Policy</b> .....	<b>12</b>
<b>Replacement Information</b> .....	<b>13</b>
<b>Contact Information</b> .....	<b>13</b>

# Introduction

The purpose of this publication is to assist with the installation, maintenance and troubleshooting of the LoadLifter5000 air spring kit. LoadLifter5000 utilizes sturdy, reinforced, commercial grade single or double, depending on the kit, convolute bellows. The bellows are manufactured like a tire with layers of rubber and cords that control growth. LoadLifter5000 kits are recommended for most  $\frac{3}{4}$  and 1 ton pickups and SUVs with leaf springs and provide up to 5,000 lbs of load leveling support with air adjustability from 5-100 p.s.i. The kits are also used in motor home rear kits and some motor home fronts where leaf springs are used.

It is important to read and understand the entire installation guide before beginning installation or performing any maintenance, service or repair. The information here includes a hardware list, tool list, step-by-step installation information and maintenance tips.

Air Lift Company reserves the right to make changes and improvements to its products and publications at any time. Contact Air Lift Company at (800) 248-0892 for the latest version of this manual.

## IMPORTANT SAFETY NOTICE

The installation of this kit does not alter the Gross Vehicle Weight Rating (GVWR) or payload of the vehicle. Check your vehicle's owner's manual and do not exceed the maximum load listed for your vehicle.

**Gross Vehicle Weight Rating:** The maximum allowable weight of the fully loaded vehicle (including passengers and cargo). This number — along with other weight limits, as well as tire, rim size and inflation pressure data — is shown on the vehicle's Safety Compliance Certification Label.

**Payload:** The combined, maximum allowable weight of cargo and passengers that the truck is designed to carry. Payload is GVWR minus the Base Curb Weight.

## NOTATION EXPLANATION

Hazard notations appear in various locations in this publication. Information which is highlighted by one of these notations must be observed to help minimize risk of personal injury or possible improper installation which may render the vehicle unsafe. Notes are used to help emphasize areas of procedural importance and provide helpful suggestions. The following definitions explain the use of these notations as they appear throughout this guide.

 **DANGER**

INDICATES IMMEDIATE HAZARDS WHICH WILL RESULT IN SEVERE PERSONAL INJURY OR DEATH.

 **WARNING**

INDICATES HAZARDS OR UNSAFE PRACTICES WHICH COULD RESULT IN SEVERE PERSONAL INJURY OR DEATH.

 **CAUTION**

INDICATES HAZARDS OR UNSAFE PRACTICES WHICH COULD RESULT IN DAMAGE TO THE MACHINE OR MINOR PERSONAL INJURY.

---

**NOTE**

*Indicates a procedure, practice or hint which is important to highlight.*

---

# Installation Diagram

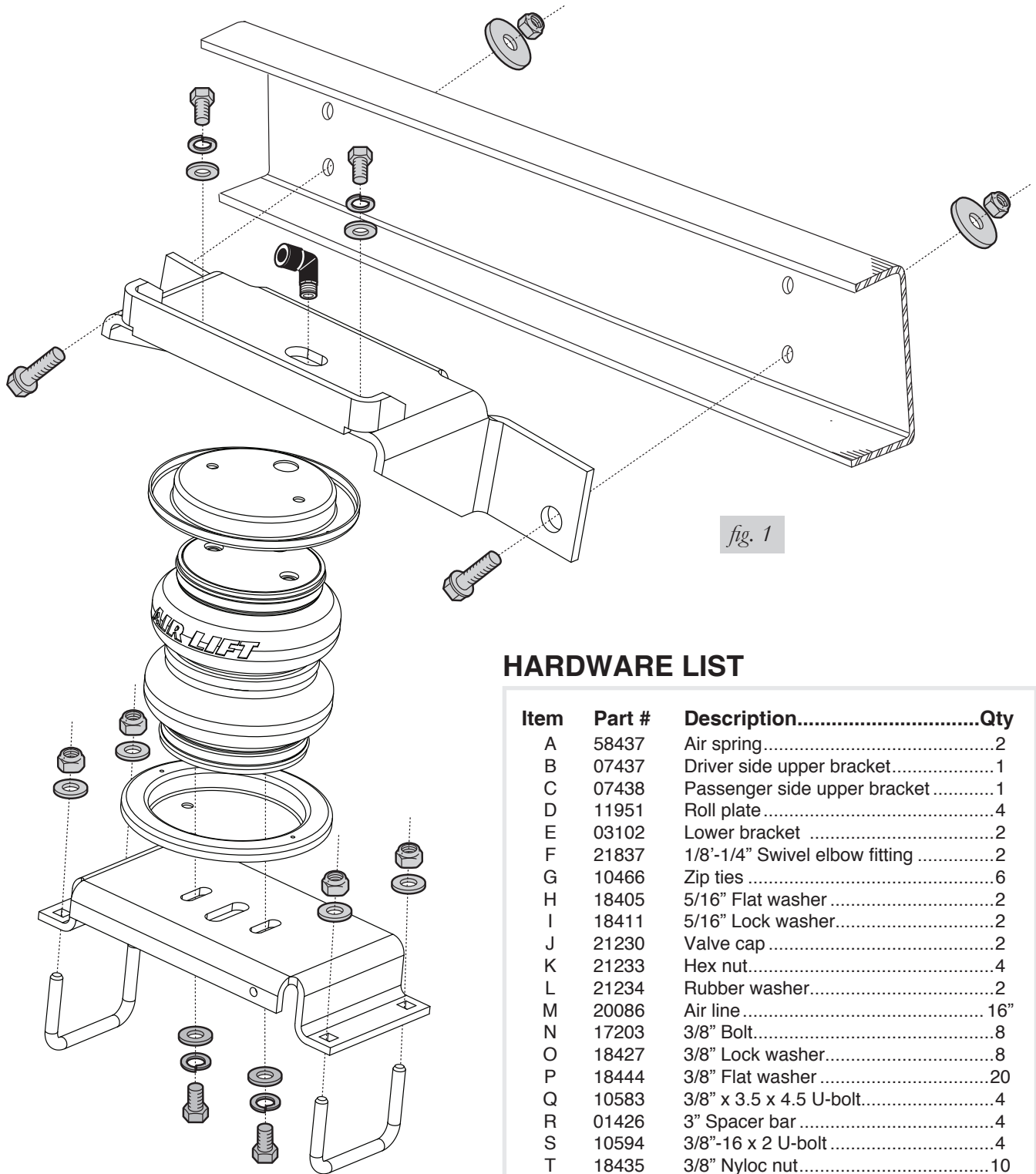

## HARDWARE LIST

Item	Part #	Description.....	Qty
A	58437	Air spring.....	2
B	07437	Driver side upper bracket.....	1
C	07438	Passenger side upper bracket.....	1
D	11951	Roll plate.....	4
E	03102	Lower bracket.....	2
F	21837	1/8'-1/4" Swivel elbow fitting.....	2
G	10466	Zip ties.....	6
H	18405	5/16" Flat washer.....	2
I	18411	5/16" Lock washer.....	2
J	21230	Valve cap.....	2
K	21233	Hex nut.....	4
L	21234	Rubber washer.....	2
M	20086	Air line.....	16"
N	17203	3/8" Bolt.....	8
O	18427	3/8" Lock washer.....	8
P	18444	3/8" Flat washer.....	20
Q	10583	3/8" x 3.5 x 4.5 U-bolt.....	4
R	01426	3" Spacer bar.....	4
S	10594	3/8"-16 x 2 U-bolt.....	4
T	18435	3/8" Nyloc nut.....	10
U	17159	3/8" Washer head bolt.....	2
V	18447	5/16" x 3/8" Large washer.....	2
W	10465	Line clamp.....	1



Missing or damaged parts? Call Air Lift customer service at (800) 248-0892 for a replacement part.

## TOOLS LIST

Description.....	Qty	Description.....	Qty
Hoist or floor jacks.....	1	Ratchet with 9/16", metric, & 1/2" deep well sockets.....	1
Safety stands.....	2	3/8" and 5/16" drill bits (very sharp).....	2
Safety glasses.....	1	Heavy duty drill.....	1
Torque wrench.....	1	Hose cutter, razor blade, or sharp knife.....	1
5/16" open-end or box wrench.....	1	Air compressor or compressed air source.....	1
7/16" open-end or box wrench.....	1	Spray bottle with dish soap/water solution.....	1
9/16" open-end or box wrench.....	1		
Crescent wrench.....	1		

# Installing the LoadLifter5000 System

## GETTING STARTED

1. Raise the vehicle, remove the wheels and obtain normal ride height (fig. 2 and fig. 3).

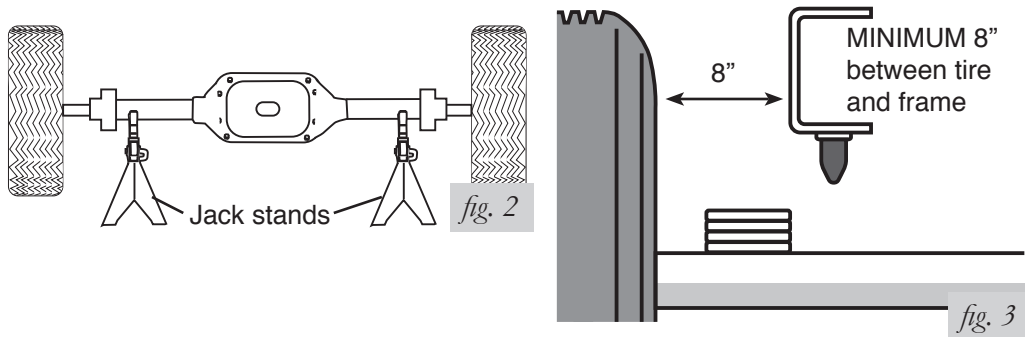

## SPECIAL APPLICATION INSTRUCTIONS

1. For B&W hitch applicatons:
  - a. On B&W part number 1199R, with the hitch in the 49" position only, trim 1/4" from the bottom of the center flange on the side plate and front cross member (fig. 4). Also, grind a slight chamfer on the back of the front mounting leg of the upper brackets to clear the bend radius of the large flange on the B&W side plate (fig. 4).

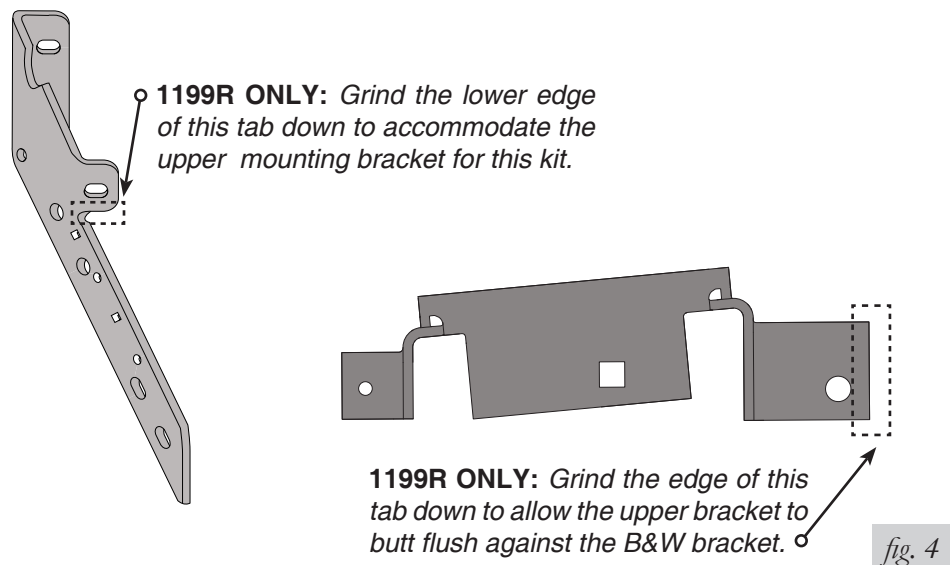

2. On 2005 models it will be necessary to remove the top rear shock bracket rivet (on the passenger side only) to mount the upper bracket (fig. 5).
3. With the B&W hitch bracket in the position described in step 1, proceed with the air spring installations.
4. Remove the emergency brake cable bracket and corresponding hardware attached to the lower spring retainer. Save the bolt for later use.

*Remove the upper left rivet to provide a hold for mounting the upper bracket.*

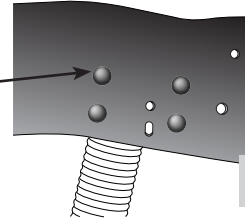

fig. 5

### ASSEMBLING THE AIR SPRING UNIT

1. Set a roll plate on both ends of the air spring. The radiused (rounded) edge of the roll plate will be towards the air spring so that the air spring is seated in both roll plates (fig. 6).
2. Install a 90° swivel air fitting finger tight plus 1 ½” turns (fig. 6). Do not overtighten.
3. The upper brackets are side specific. The small mounting hole in the upper bracket faces forward (fig. 6).
4. Place the driver side upper bracket on top of the bellow and roll plate with the legs facing down.
5. Set the air spring on the driver side lower bracket and align the two holes in the base of the air spring with the two outer slots in the top of the lower bracket (fig. 6). Repeat this procedure for the passenger side assembly.
6. Loosely attach the lower bracket to the assembly using flat washers, lock washers, and hex head bolts. See fig. 6.

#### NOTE

*The flange on the lower bracket must face the outside (tire-side) of the vehicle.*

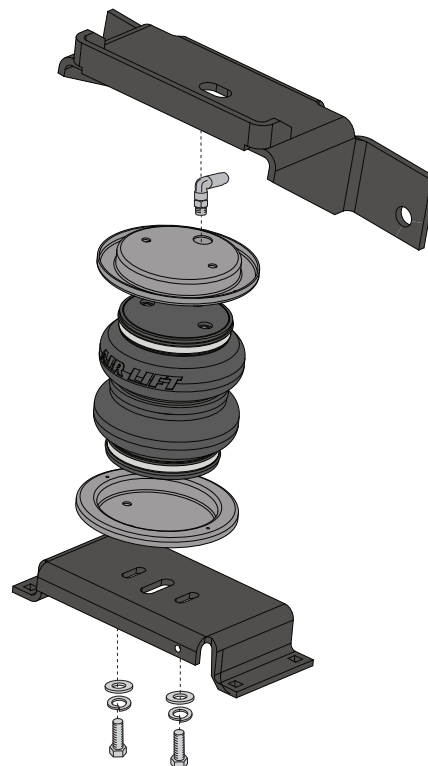

fig. 6

## REMOVING THE PASSENGER SIDE SHOCK BRACKET RIVET

1. Remove the rear, top shock mounting rivet on the passenger side of the vehicle to provide a mounting hole for the upper bracket (see fig. 5).

## ATTACHING THE LOWER BRACKET

1. Set the air spring over the axle (fig. 7 and fig. 8).
2. Take two spacer bars and slide one under the front leg and one under the rear leg of the lower bracket (fig. 8).
3. Depending on whether the vehicle has frame contact overloads or a regular leaf stack, attach the lower bracket to the leaf using the provided u-bolts (fig. 7 and fig. 8). Torque to 16 ft/lbs.

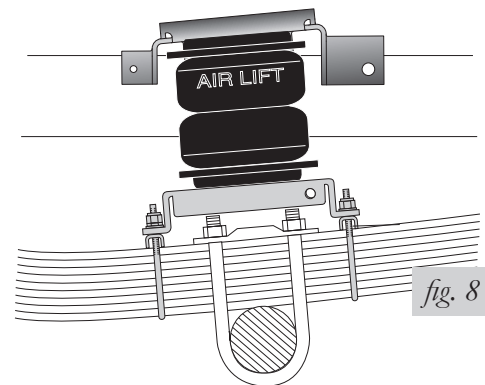
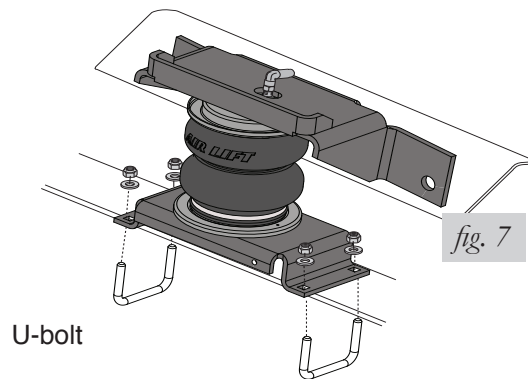

## ATTACHING THE UPPER BRACKET

1. For B&W hitch applications:
  - a. Align the two large holes with the existing B&W hitch frame brackets. Use the existing  $\frac{3}{4}$ " hardware supplied by B&W to attach the bracket.
2. Align the upper bracket so that it is parallel to the lower bracket. Torque the  $\frac{3}{8}$ " hardware to 40 ft.lbs. Torque the  $\frac{3}{4}$ " hardware to 90 ft/lbs.

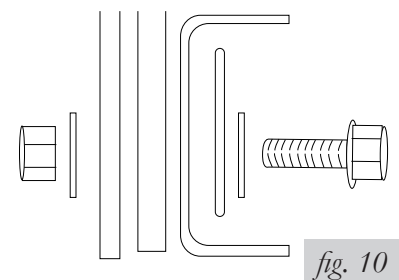
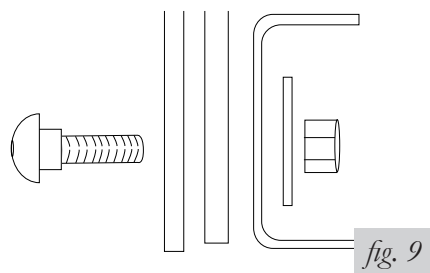

## SECURING THE AIR SPRING TO THE BRACKETS

1. The upper bracket is slotted so that the air spring can be adjusted forward and back. The bottom bracket is slotted so that the air spring can be adjusted in and out.
2. Using the slots in the top and bottom brackets, adjust the air spring so that it is perpendicular to both surfaces. Tighten top and bottom mounting hardware to no more than 10 ft/lbs.

## INSTALLING THE AIR LINES

1. Choose a convenient location for mounting the inflation valves. Popular locations for the inflation valve are:
  - a. The wheel well flanges.
  - b. License plate recess in bumper.
  - c. Under the gas cap access door.
  - d. Through license plate itself.

### NOTE

*What ever the chosen location is, make sure there is enough clearance around the inflation valves for an air chuck.*

### CAUTION

2. Drill a 5/16" hole to install the inflation valves.
3. Cut the air line assembly in two equal lengths.
 

WHEN CUTTING OR TRIMMING THE AIR LINE, USE A HOSE CUTTER, A RAZOR BLADE OR A SHARP KNIFE. A CLEAN, SQUARE CUT WILL ENSURE AGAINST LEAKS. DO NOT USE WIRE CUTTERS OR SCISSORS TO CUT THE AIR LINE. THESE TOOLS MAY FLATTEN OR CRIMP THE AIR LINE, CAUSING IT TO LEAK AROUND THE O-RING SEAL INSIDE THE ELBOW FITTING (FIG. 11)

4. Place a 5/16" nut and a star washer on the air valve. Leave enough of the inflation valve in front of the nut to extend through the hole and have room for the rubber washer, flat washer, and 5/16" nut and cap. There should be enough valve exposed after installation - approximately 1/2" - to easily apply a pressure gauge or an air chuck (fig. 12).
5. Push the inflation valve through the hole and use the rubber washer, flat washer, and another 5/16" nut. Tighten the nuts to secure the assembly in place (fig. 12).

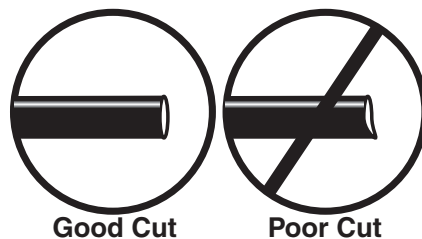

fig. 11

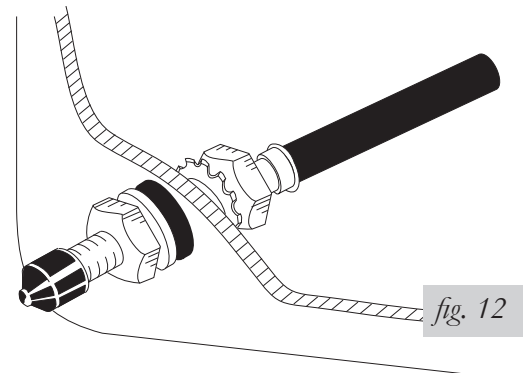

fig. 12

6. Route the air line along the frame to the air fitting on the air spring (fig. 3). Keep AT LEAST 6" of clearance between the air line and heat sources, such as the exhaust pipes, muffler, or catalytic converter. Avoid sharp bends and edges. Use the plastic tie straps to secure the air line to fixed, non-moving points along the chassis. Be sure that the tie straps are tight, but do not pinch the air line. Leave at least 2" of slack to allow for any movement that might pull on the air line.

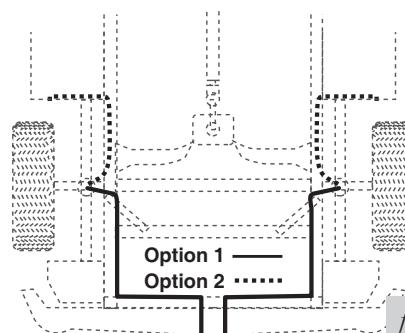
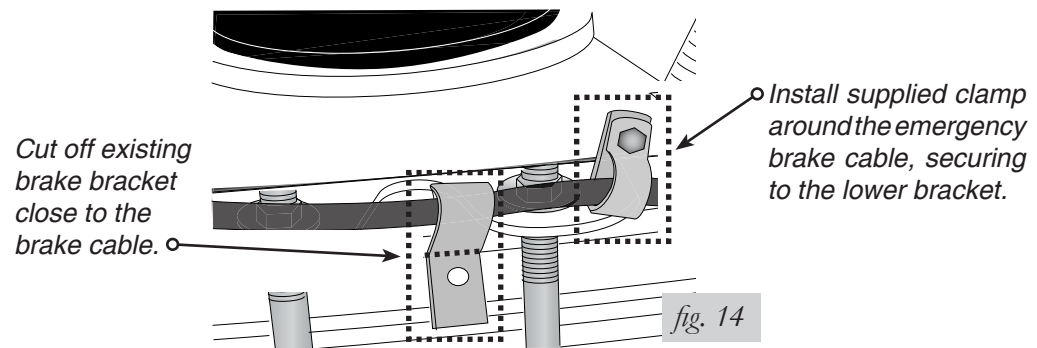

fig. 13

7. Cut off air line leaving approximately 12" of extra air line. A clean square cut will ensure against leaks (see fig. 11). Insert the air line into the air fitting. This is a push to connect fitting. Simply push the air line into the 90° swivel fitting until it bottoms out (9/16" of air line should be in the fitting).

## SECURING THE EMERGENCY BRAKE CABLE

1. Attach the supplied clamp around the emergency brake cable and secure it to the lower bracket using the previously removed stock bolt. Tighten securely (fig. 14).
2. Cut the existing emergency brake cable bracket close to the cable (fig. 14).



## CHECKING FOR LEAKS

1. Inflate the air spring to 30 p.s.i. and spray all connections and the inflation valves with a solution of 1/5 liquid dish soap and 4/5 water to check for leaks. Spot leaks easily by looking for bubbles in the soapy water.
2. After the test, deflate the springs to the minimum pressure required to restore the normal ride height, no less than 5 p.s.i.
3. Check the air pressure again after 24 hours. A 2-4 p.s.i. loss after initial installation is normal. Retest for leaks if the loss is more than 5 lbs.

## FIXING LEAKS

1. If there is a problem with the swivel fitting:
  - a. Check the air line connection by deflating the spring and removing the line by pulling the collar against the fitting and pulling firmly on the air line. Trim 1" off the end of the air line. Be sure the cut is clean and square (see fig. 11). Reinsert the air line into the push-to-connect fitting.
  - b. Check the threaded connection by tightening the swivel fitting another 1/2 turn. If it still leaks, deflate the air spring, remove the fitting, and re-coat the threads with thread sealant. Reinstall by hand tightening as much as possible, then use a wrench for an additional two turns.
2. If there is a problem with the inflation valve, then:
  - a. Check the valve core by tightening it with a valve core tool.
  - b. Check the air line connection by removing the air line from the barbed type fitting.

### CAUTION

DO NOT CUT THE AIR LINE COMPLETELY OFF AS THIS WILL NICK THE BARB AND RENDER THE FITTING USELESS.

3. If the preceding steps have not resolved the problem, call Air Lift customer service at (800) 248-0892 for assistance.

# Before Operating

## INSTALLATION CHECKLIST (To be completed by installer)

- Clearance test — Inflate the air springs to 60 PSI and ensure there is at least ½” clearance around each bellow, away from anything that might rub against them. Be sure to check the tire, brake drum, frame, shock absorbers and brake cables.
- Leak test before road test — Inflate the air springs to 60 PSI, check all connections for leaks with a soapy water solution. See page ?? for tips on how to spot leaks. All leaks must be eliminated before the vehicle is road tested.
- Heat test — Be sure there is sufficient clearance from any heat sources — at least 6” for air springs and air lines. If a heat shield was included in the kit, install it. If there is no heat shield, but one is required, call (800) 248-0892.
- Fastener test — Recheck all bolts for proper torque. Axle straps carriage bolt lock nuts should be torqued to 16 ft/lbs. Re-torque after 100 miles.
- Road test — The vehicle should be road tested after the preceding tests. Inflate the air springs to 25 PSI (50 PSI if the vehicle is loaded). Drive the vehicle 10 miles and recheck for clearance, loose fasteners and air leaks.
- Operating instructions — If professionally installed, the installer should review the Product Use, Maintenance and Servicing section on page ?? with the owner. Be sure to provide the owner with all of the paperwork which came with the kit.

**Technician's Signature** \_\_\_\_\_

**Date** \_\_\_\_\_

## POST-INSTALLATION CHECKLIST

- Overnight leak down test — Recheck air pressure after the vehicle has been used for 24 hours. If the pressure has dropped more than 5 PSI, then there is a leak that must be fixed. Either fix the leak yourself or return to the installer for service.
- Air pressure requirements — I understand the air pressure requirements of my air spring system. Regardless of load, the air pressure should always be adjusted to maintain ride height at all times.
- Thirty day or 500 mile test — I understand that I must recheck the air spring system after 30 days or 500 miles, whichever comes first. If any part shows signs of rubbing or abrasion, the source should be identified and moved, if possible. If it is not possible to relocate the cause of the abrasion, the air spring may need to be remounted. If professionally installed, the installer should be consulted. Check all fasteners for tightness.

# Product Use, Maintenance and Servicing

Minimum Air Pressure	Maximum Air Pressure
10 p.s.i.	100 p.s.i.
FAILURE TO MAINTAIN CORRECT MINIMUM PRESSURE (OR PRESSURE PROPORTIONAL TO LOAD), BOTTOMING OUT, OVER-EXTENSION OR RUBBING AGAINST ANOTHER COMPONENT WILL VOID THE WARRANTY.	

## MAINTENANCE GUIDELINES

### NOTE

*By following these steps, vehicle owners will obtain the longest life and best results from their air spring.*

1. Check the air pressure weekly.
2. Always maintain normal ride height. Never inflate beyond 100 p.s.i.
3. If you develop an air leak in the system, use a soapy water solution to check all air line connections and the inflation valve core, before deflating and removing the spring.
4. When increasing load, always adjust the air pressure to maintain normal ride height. Increase or decrease pressure from the system as necessary to attain normal ride height for optimal ride and handling. Remember that loads carried behind the axle (including tongue loads) require more leveling force (pressure) than those carried directly over the axle.

### CAUTION

FOR YOUR SAFETY AND TO PREVENT DAMAGE TO YOUR VEHICLE, DO NOT EXCEED MAXIMUM GROSS VEHICLE WEIGHT RATING (GVWR), AS INDICATED BY THE VEHICLE MANUFACTURER. ALTHOUGH YOUR AIR SPRINGS ARE RATED AT A MAXIMUM INFLATION PRESSURE OF 100 P.S.I., THE AIR PRESSURE ACTUALLY NEEDED IS DEPENDENT ON YOUR LOAD AND GVWR.

5. Always add air to the springs in small quantities, checking the pressure frequently. Sleeves require less air volume than a tire and inflate quickly.
6. Should it become necessary to raise the vehicle by the frame, make sure the system is at a minimum pressure (5 p.s.i.) to reduce tension on the suspension/brake components. Use of on-board leveling systems do not require deflation or disconnection.

## TROUBLESHOOTING GUIDE

1. Leak test the air line connections, the threaded connection into the air spring, and all fittings in the control system.
2. Inspect the air lines to be sure none are pinched. Tie straps may be too tight. Loosen or replace the strap and replace leaking components.
3. Inspect the air line for holes and cracks. Replace as needed.
4. Look for a kink or fold in the air line. Reroute as needed.

If the preceding steps do not solve the problem, it is possibly caused by a failed air spring — either a factory defect or an operating problem. Please call Air Lift at (800) 248-0892 for assistance.

## FREQUENTLY ASKED QUESTIONS

### **Q. Will installing air springs increase the weight ratings of a vehicle?**

No. Adding air springs will not change the weight ratings (GAWR, GCWR and/or GVWR) of a vehicle. Exceeding the GVWR is dangerous and voids the Air Lift warranty.

**Q. Is it necessary to keep air in the air springs at all times and how much pressure will they need?**

The minimum air pressure should be maintained at all times. The minimum air pressure keeps the air spring in shape, ensuring that it will move throughout its travel without rubbing or wearing on itself.

**Q. Is it necessary to add a compressor system to the air springs?**

No. Air pressure can be adjusted with any type of compressor as long as it can produce sufficient pressure to service the springs. Even a bicycle tire pump can be used, but it's a lot of work.

**Q. How long should air springs last?**

If the air springs are properly installed and maintained they can last indefinitely.

**Q. Will raising the vehicle on a hoist for service work damage the air springs?**

No. The vehicle can be lifted on a hoist for short-term service work such as tire rotation or oil changes. However, if the vehicle will be on the hoist for a prolonged period of time, support the axle with jack stands in order to take the tension off of the air springs.

## TUNING THE AIR PRESSURE

Pressure determination comes down to three things — level vehicle, ride comfort, and stability.

### 1. Level vehicle

If the vehicle's headlights are shining into the trees or the vehicle is leaning to one side, then it is not level (fig. 15). Raise the air pressure to correct either of these problems and level the vehicle.

### 2. Ride comfort

If the vehicle has a rough and harsh ride it may be due to either too much pressure or not enough (fig. 16). Try different pressures to determine the best ride comfort.

### 3. Stability

Stability translates into safety and should be the priority, meaning the driver may need to sacrifice a perfectly level and comfortable ride. Stability issues include roll control, bounce, dive during braking and sponginess (fig. 17). Tuning out these problems usually requires an increase in pressure.



Sway and body roll

## GUIDELINES FOR ADDING AIR

1. Start with the vehicle level or slightly above.
2. When in doubt, always add air.
3. For motorhomes, start with 50-100 PSI in the rear because it can be safely assumed that it is heavily loaded.
4. If the front of the vehicle dives while braking, increase the pressure in the front air bags, if equipped.

5. If it is ever suspected that the air bags have bottomed out, increase the pressure (fig. 18).
6. Adjust the pressure up and down to find the best ride.
7. If the vehicle rocks and rolls, adjust the air pressure to reduce movement.
8. It may be necessary to maintain different pressures on each side of the vehicle. Loads such as water, fuel, and appliances will cause the vehicle to be heavier on one side (fig. 19). As much as a 50 PSI difference is not uncommon.

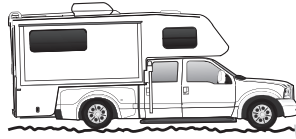
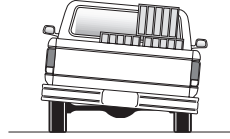
 Bottoming out *fig. 18*

Unlevel

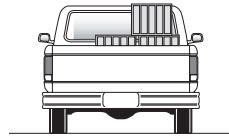

Level

*fig. 19*

## Warranty and Returns Policy

Air Lift Company warrants its products, for the time periods listed below, to the original retail purchaser against manufacturing defects when used on catalog-listed applications on cars, vans, light trucks and motorhomes under normal operating conditions for as long as Air Lift manufactures the product. The warranty does not apply to products that have been improperly applied, improperly installed, used in racing or off-road applications, used for commercial purposes, or which have not been maintained in accordance with installation instructions furnished with all products. The consumer will be responsible for removing (labor charges) the defective product from the vehicle and returning it, transportation costs prepaid, to the dealer from which it was purchased or to Air Lift Company for verification.

Air Lift will repair or replace, at its option, defective products or components. A minimum \$10.00 shipping and handling charge will apply to all warranty claims. Before returning any defective product, you must call Air Lift at (800) 248-0892 in the U.S. and Canada (elsewhere, (517) 322-2144) for a Returned Materials Authorization (RMA) number. Returns to Air Lift can be sent to: Air Lift Company • 2727 Snow Road • Lansing, MI • 48917.

Product failures resulting from abnormal use or misuse are excluded from this warranty. The loss of use of the product, loss of time, inconvenience, commercial loss or consequential damages is not covered. The consumer is responsible for installation/reinstallation (labor charges) of the product. Air Lift Company reserves the right to change the design of any product without assuming any obligation to modify any product previously manufactured.

This warranty gives you specific legal rights and you may also have other rights that vary from state-to-state. Some states do not allow limitations on how long an implied warranty lasts or allow the exclusion or limitation of incidental or consequential damages. The above limitation or exclusion may not apply to you. There are no warranties, expressed or implied including any implied warranties of merchantability and fitness, which extend beyond this warranty period. There are no warranties that extend beyond the description on the face hereof. Seller disclaims the implied warranty of merchantability. (Dated proof of purchase required.)

<b>Air Lift 1000</b> .....	<b>Lifetime Limited</b>	<b>LoadController/Dual</b> .....	<b>2 Year Limited</b>
<b>RideControl</b> .....	<b>Lifetime Limited</b>	<b>Load Controller (I)</b> .....	<b>2 Year Limited</b>
<b>LoadLifter 5000*</b> .....	<b>Lifetime Limited</b>	<b>Load Controller (II)</b> .....	<b>2 Year Limited</b>
<b>SlamAir</b> .....	<b>Lifetime Limited</b>	<b>SmartAir</b> .....	<b>2 Year Limited</b>
<b>AirCell</b> .....	<b>Lifetime Limited</b>	<b>Wireless AIR</b> .....	<b>2 Year Limited</b>
<b>Lifestyle &amp; Performance**</b> ....	<b>1 Year Limited</b>	<b>WirelessONE</b> .....	<b>2 Year Limited</b>
<b>LoadController/Single</b> .....	<b>2 Year Limited</b>	<b>Other Accessories</b> .....	<b>2 Year Limited</b>

*\*formerly SuperDuty*

*\*\*formerly EasyStreet*

---

## Replacement Information

If you need replacement parts, contact the local dealer or call Air Lift customer service at (800) 248-0892. Most parts are immediately available and can be shipped the same day.

**Contact Air Lift Company customer service at (800) 248-0892 first if:**

- Parts are missing from the kit.
- Need technical assistance on installation or operation.
- Broken or defective parts in the kit.
- Wrong parts in the kit.
- Have a warranty claim or question.

**Contact the retailer where the kit was purchased:**

- If it is necessary to return or exchange the kit for any reason.
- If there is a problem with shipping if shipped from the retailer.
- If there is a problem with the price.

## Contact Information

If you have any questions, comments or need technical assistance contact our customer service department by calling (800) 248-0892, Monday through Friday. For calls from outside the USA or Canada, our local number is (517) 322-2144.

For inquiries by mail, our address is PO Box 80167, Lansing, MI 48908-0167. Our shipping address for returns is 2727 Snow Road, Lansing, MI 48917.

You may also contact us anytime by e-mail at [sales@airliftcompany.com](mailto:sales@airliftcompany.com) or on the web at [www.airliftcompany.com](http://www.airliftcompany.com).

## Need Help?

Contact our customer service department by calling (800) 248-0892, Monday through Friday. For calls from outside the USA or Canada, our local number is (517) 322-2144.

**Register your warranty online at  
[www.airliftcompany.com/warranty](http://www.airliftcompany.com/warranty)**



*Thank you for purchasing Air Lift products — the professional installer's choice!*

Air Lift Company • 2727 Snow Road • Lansing, MI 48917 or PO Box 80167 • Lansing, MI 48908-0167  
Toll Free (800) 248-0892 • Local (517) 322-2144 • Fax (517) 322-0240 • [www.airliftcompany.com](http://www.airliftcompany.com)

Printed in  
the USA