

LoadLIFTER™ 5000

by AIR LIFT®

Kit 57398

Ford F-250/F-350
(Single and Dual Rear Wheel)
4-Wheel Drive

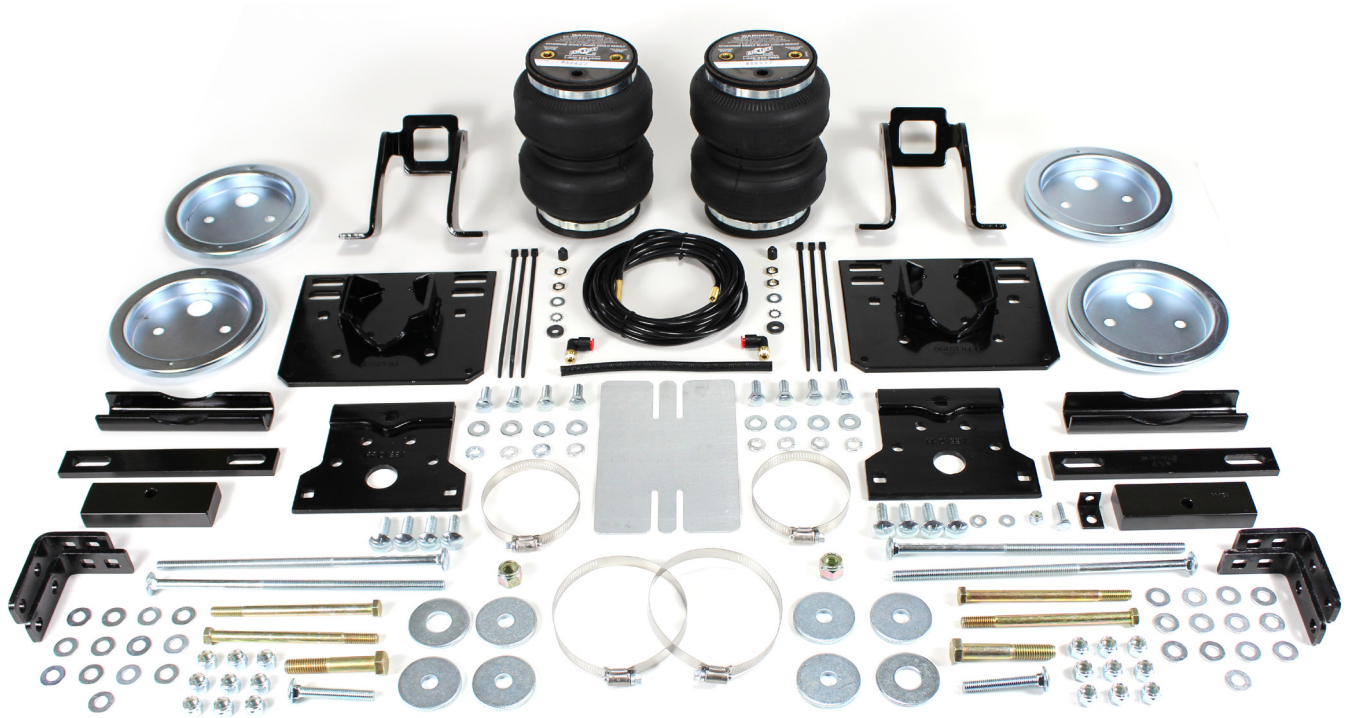

INSTALLATION GUIDE

For maximum effectiveness and safety, please read these instructions completely before proceeding with installation.

Failure to read these instructions can result in an incorrect installation.

TABLE OF CONTENTS

Introduction	2
Important Safety Notice	2
Notation Explanation	2
Installation Diagram	3
Hardware and Tools Lists	4
Installing the LoadLifter 5000 System	5
Getting Started	5
Side Brace Installation.	6
Bellows and Bracket Assembly	7
Attaching the Assemblies to the Frame.	8
Lower Bracket Attachment	9
Final Steps.	10
Installing the Air Lines	11
Installing the Heat Shield.	12
Checking for Leaks	12
Fixing Leaks	12
Before Operating	13
Installation Checklist	13
Post-Installation Checklist	13
Product Use, Maintenance and Servicing	14
Minimum and Maximum Pressure	14
Maintenance Guidelines	14
Troubleshooting Guide	14
Frequently Asked Questions	15
Tuning the Air Pressure.	15
Guidelines for Adding Air.	16
Warranty and Returns Policy	16
Replacement Information	17
Contact Information	17

Introduction

The purpose of this publication is to assist with the installation, maintenance and troubleshooting of the LoadLifter 5000 air spring kit. LoadLifter 5000 utilizes sturdy, reinforced, commercial grade single or double, depending on the kit, convolute bellows. The bellows are manufactured like a tire with layers of rubber and cords that control growth. LoadLifter 5000 kits are recommended for most 3/4 and 1 ton pickups and SUVs with leaf springs and provide up to 5,000 lbs. of load leveling support with air adjustability from 5-100 PSI. The kits are also used in motor home rear kits and some motor home fronts where leaf spring are used.

It is important to read and understand the entire installation guide before beginning installation or performing any maintenance, service or repair. The information here includes a hardware list, tool list, step-by-step installation information, maintenance guidelines and operating tips.

Air Lift Company reserves the right to make changes and improvements to its products and publications at any time. For the latest version of this manual, contact Air Lift Company at (800) 248-0892 or visit our website at www.airliftcompany.com.

IMPORTANT SAFETY NOTICE

The installation of this kit does not alter the Gross Vehicle Weight Rating (GVWR) or payload of the vehicle. Check your vehicle's owner's manual and do not exceed the maximum load listed for your vehicle.

Gross Vehicle Weight Rating: The maximum allowable weight of the fully loaded vehicle (including passengers and cargo). This number — along with other weight limits, as well as tire, rim size and inflation pressure data — is shown on the vehicle's Safety Compliance Certification Label.

Payload: The combined, maximum allowable weight of cargo and passengers that the truck is designed to carry. Payload is GVWR minus the Base Curb Weight.

NOTATION EXPLANATION

Hazard notations appear in various locations in this publication. Information which is highlighted by one of these notations must be observed to help minimize risk of personal injury or possible improper installation which may render the vehicle unsafe. Notes are used to help emphasize areas of procedural importance and provide helpful suggestions. The following definitions explain the use of these notations as they appear throughout this guide.

DANGER

INDICATES IMMEDIATE HAZARDS WHICH WILL RESULT IN SEVERE PERSONAL INJURY OR DEATH.

WARNING

INDICATES HAZARDS OR UNSAFE PRACTICES WHICH COULD RESULT IN SEVERE PERSONAL INJURY OR DEATH.

CAUTION

INDICATES HAZARDS OR UNSAFE PRACTICES WHICH COULD RESULT IN DAMAGE TO THE MACHINE OR MINOR PERSONAL INJURY.

NOTE

Indicates a procedure, practice or hint which is important to highlight.

Installation Diagram

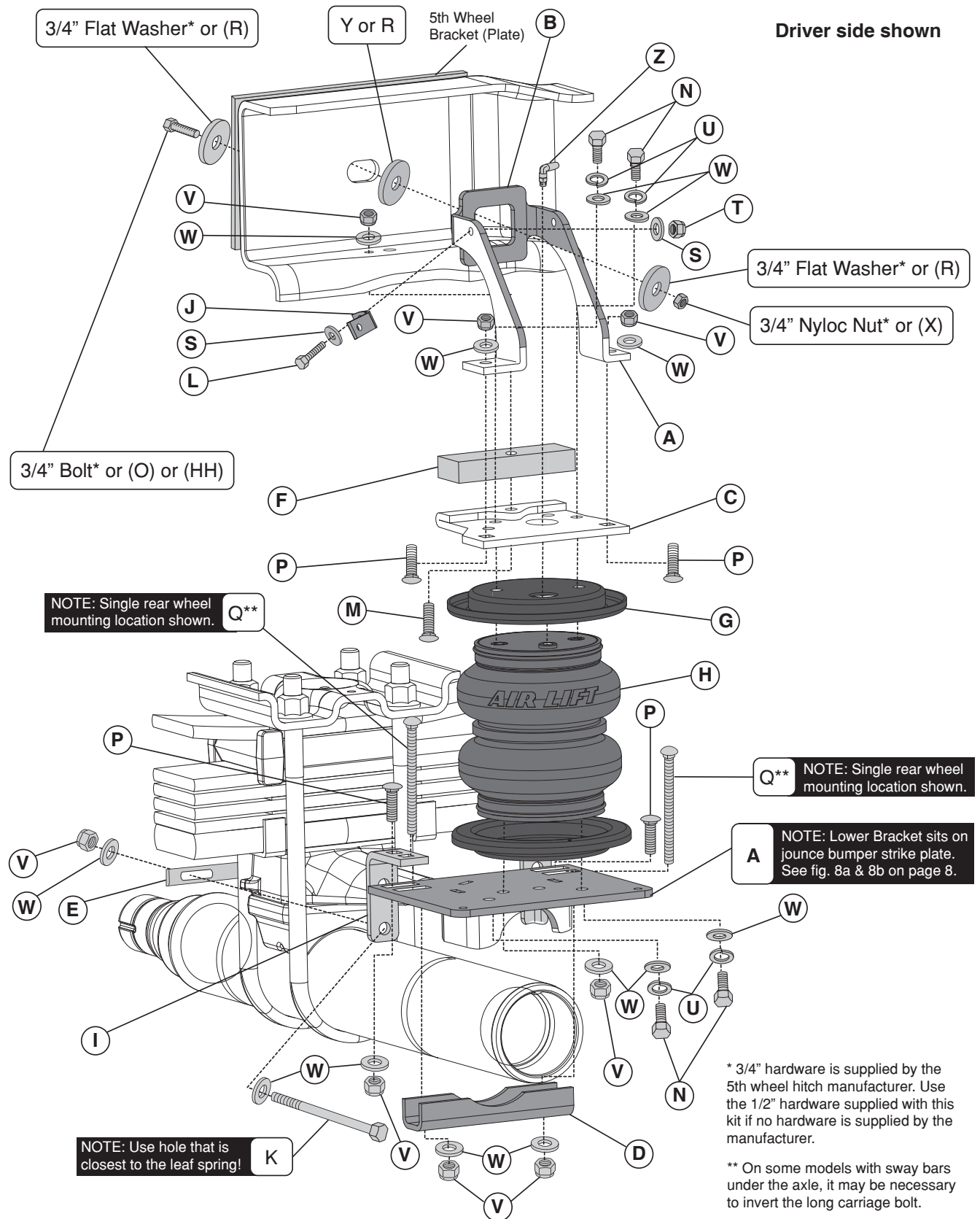

fig. 1

Hardware and Tools Lists

HARDWARE LIST

Item	Part #	Description	Qty	Item	Part #	Description	Qty
A	03990	Lower Bracket.....	2	R	18207	1/2" Thick Flat Washer.....	6
B	07996	Upper Brace.....	2	S	18419	Flat Washer #12.....	2
C	07997	Upper Bracket.....	2	T	18425	1/4"-20 Nyloc Nut.....	1
D	01531	Clamp Bar.....	2	U	18427	3/8" Lock Washer.....	8
E	10861	Spring Clamp Bar.....	2	V	18435	3/8"-16 Nyloc Nut.....	18
F	13966	Spacer.....	2	W	18444	3/8" Flat Washer.....	34
G	11951	Roll Plate.....	4	X	18460	1/2-13" Nyloc Nut.....	2
H	58437	Bellows.....	2	Y	18556	3/4" Flat Washer.....	2
I	10880	Four Hole Locating Bracket.....	4	Z	21837	90 ° Swivel Air Fitting.....	2
J	10886	"L" Bracket.....	1	AA	10466	Zip Ties.....	6
K	17110	3/8-16 x 5.5 Hex Head Cap Screw.....	4	BB	18411	5/16" Lock Washer.....	2
L	17135	1/4"-20 x 1" Hex Cap Screw.....	1	CC	21230	Valve Caps.....	2
M	17141	3/8-16 x 2.5" Carriage Bolt.....	2	DD	21233	5/16" Hex Nut.....	2
N	17203	3/8-24 x 7/8" Hex Head Cap Screw.....	8	EE	21234	Rubber Washer.....	2
O	17271	1/2"-13 x 3" Hex Cap Screw.....	2	FF	20086	Air Line Assembly.....	1
P	17361	3/8-16 x 1.25" Carriage Bolt.....	8	GG	34924	Heat Shield Kit.....	1
Q	17387	3/8-16 x 10" Carriage Bolt.....	4	HH	17208	1/2-13 x 2" Hex Head Cap Screw.....	2

TOOLS LIST

Description.....	Qty
7/16" and 9/16" Open-end or box wrenches.....	2
Crescent wrench.....	1
Ratchet with 3/8", 9/16", & 1/2" deep well sockets.....	1
5/16" drill bits (very sharp).....	1
DIR grinder.....	1
Hacksaw.....	1
Heavy duty drill.....	1
Torque wrench.....	1
Standard, metric and SAE sockets and wrenches.....	1
Hose cutter, razor blade, or sharp knife.....	1
Hoist or floor jacks.....	1
Safety stands.....	1
Safety glasses.....	1
Air compressor or compressed air source.....	1
Spray bottle with dish soap/water solution.....	1



Missing or damaged parts? Call Air Lift customer service at (800) 248-0892 for a replacement part.

Installing the LoadLifter 5000 System

GETTING STARTED

1. Raise the vehicle and support the axle with jack stands, setting the jack stands as wide as possible on the axle (fig. 2).

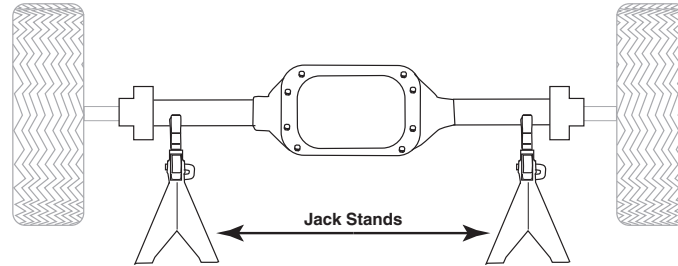

fig. 2

2. Remove the jounce bumpers from under the frame, over the axle.
3. If necessary, disconnect the wiring harness from the driver side frame rail to gain clearance for the upper brace.
4. For all dual rear wheel vehicles (DRW) it will be necessary to remove the sway bar strap and bolts holding the sway bar to the axle. Retain for later reinstallation.
5. If you have a fifth wheel hitch already installed, it will be necessary to remove the $\frac{3}{4}$ " hardware that bolts the side bracket to the outside of the frame above the axle (fig. 1).

NOTE

Some hitch models have a spacer between the bracket and the frame rail. Be sure to reinstall the spacer when attaching the upper bracket.

NOTE

If your model truck has emission lines running along the inside of the frame rail (fig. 3), it will be necessary to relocate those lines as follows. Follow the directions in the section, "Attaching the Assemblies to the Frame" for reattaching these lines.

- *Carefully push the line holder out of the frame above the axle. Try to minimize damage because it will be reused later. It may also be helpful to remove any holders forward or rearward of the axle to aid in positioning the lines once the upper bracket has been installed (fig. 3).*
- *Attach the L-bracket (J) to the back frame brace using the 1/4" bolt (L), flat washers (S) and nyloc nut (T) supplied (fig. 1). This L-bracket will eventually be used to attach the previously removed emissions line. Do not attach the line holder to it at this time.*

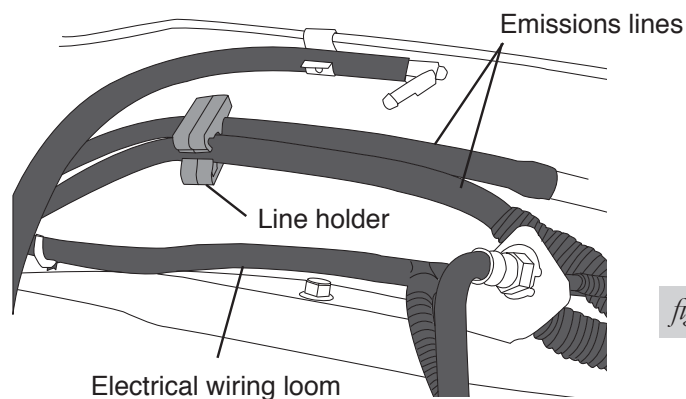
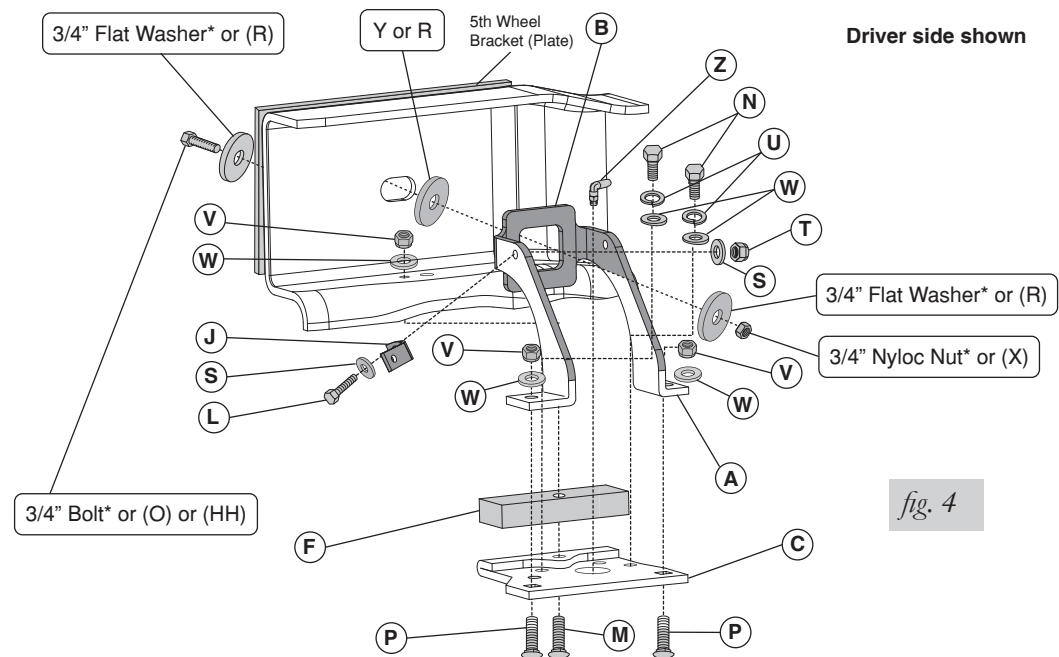

fig. 3

SIDE BRACE INSTALLATION

fig. 4

1. Set the upper brace (B) into the driver and passenger side frame (fig. 4).

If you have no fifth wheel hitch or a hitch that does not have a plate running alongside the full length of the frame (these will have an “L” bracket forward and behind the axle leaving the middle frame open) use the 1/2-13 x 2.00” Hex Cap Screw (HH) with a flat washer (R) through the slot in the side of the frame, then through another flat washer (R) and finally through the upper brace. Cap with a flat washer (R) and a 1/2-13 nyloc nut (X) (fig. 5). Leave loose at this time.

OR

If you have an aftermarket fifth wheel hitch that has a bracket (plate) running alongside of the frame and it used the slot to secure the bracket to the frame with existing hardware, install the existing hardware previously removed in the “getting started section” from the fifth wheel installation for securing the brace (fig. 4). Make sure to install the large 3/4” flat washer (Y) between the brace and the frame (fig. 1 and 4). Do not tighten at this time.

OR

If you have an aftermarket fifth wheel hitch that has a bracket (plate) running alongside of the frame and it does not have any attaching hardware on the side where the slot in the frame is, it will be necessary to drill a 1/2” hole through the plate using the slot in the frame as a template.

NOTE

It may be necessary to mark and remove the bracket (plate) from the side of the frame in order to drill the hole correctly. Re-attach once the hole is drilled.

Insert a 1/2”-13 x 3.00” hex cap screw (O) with a flat washer (R) through the fifth wheel plate previously drilled, the frame, then through another flat washer (R) and finally the upper brace. Cap with a flat washer (R) and a 1/2”-13 nyloc nut (X) (fig. 5). Leave loose at this time.

BELLOWS AND BRACKET ASSEMBLY

1. Set a roll plate (G) over the top and bottom of the bellows (H) (fig. 1).

NOTE

The radiused (rounded) edge of the roll plate (G) will be towards the bellows so that the bellows is seated inside both roll plates.

2. Install the swivel elbow fitting (Z) into the top of the bellows finger tight. Tighten the swivel fitting one and a half turns.
3. The lower bracket (A) has two sets of bellows mounting holes. Using the corresponding holes in the lower bracket designated (fig. 5), attach the bellows to the brackets using the 3/8" flat washers (W), lock washers (U), and 3/8"-24 x 7/8" hex head cap screws (N). Torque both mounting screws to 20 ft/lbs.

NOTE

The fitting on top of the bellows points inward (fig. 7).

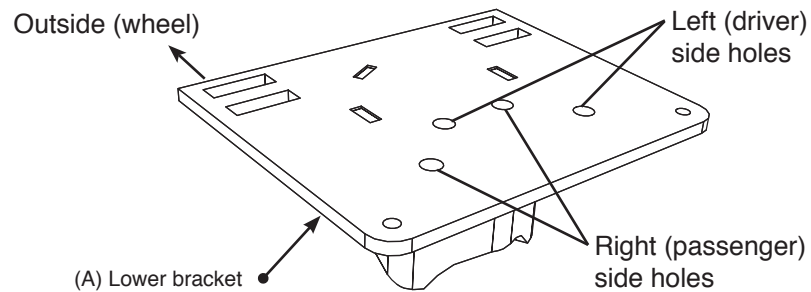

fig. 5

4. Insert two 3/8"-16 x 1.25" carriage bolts (P) up through the bottom of the upper brackets (fig. 6), through the two square holes that are on the corresponding side. Also, insert one 3/8"-16 x 2.5" carriage bolt (M) through the remaining hole. The head of this carriage bolt will be hidden once mounted to the bellows.
5. Set the driver side (left) upper bracket onto the driver side bellows assembly previously assembled, using the holes in the upper bracket designated (fig. 6), and attach to the bellows with two 3/8" flat washers (W), lock washers (U), and 3/8"-24 x 7/8" hex head cap screws (N). Torque both mounting screws to 20 ft/lbs.
6. Repeat the above process for the opposite side assembly (fig. 7).
7. Set the spacer (F) over both long carriage bolts (fig. 7).

NOTE

The hole in the flat spacer (F) is offset. Install the spacer so that the wide portion faces the outside of the vehicle (fig. 7).

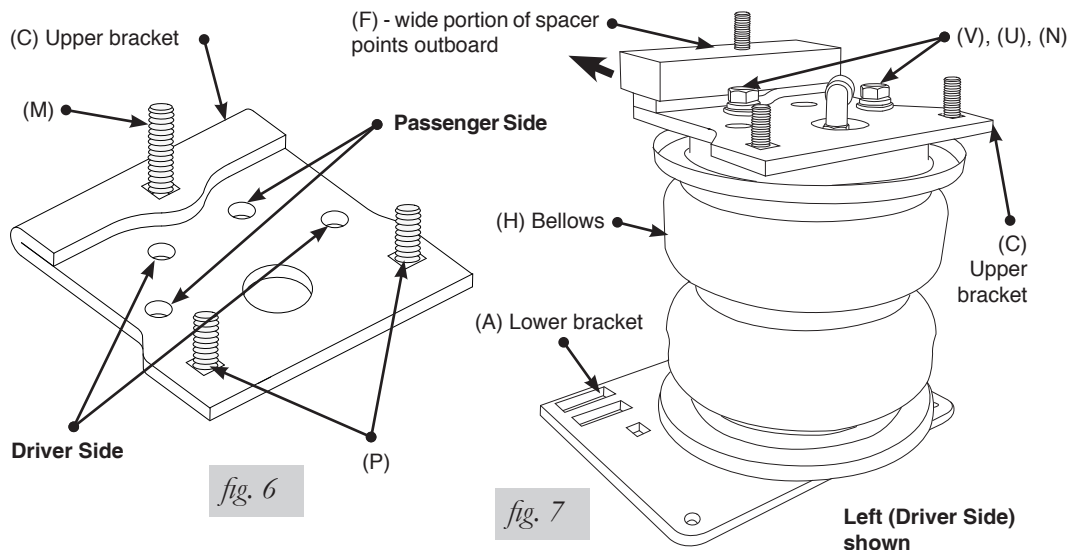
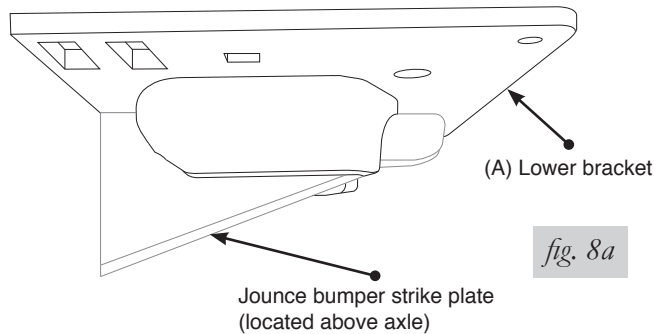

fig. 6

fig. 7

ATTACHING THE ASSEMBLIES TO THE FRAME

1. If not done so yet, drop the axle or raise the frame up to make room for the assemblies to be put into position.
2. Set the left (driver side) assembly onto the jounce bumper strike plate (figs. 8a & 8b). Raise the axle just enough to insert the long carriage bolt (M - that is installed in the upper bracket) through the existing jounce bumper hole in the bottom of the frame. At the same time, line up the upper brace previously installed onto the remaining two carriage bolts (P) in the upper bracket. Do this just enough for the carriage bolt to hold the assembly into position on the jounce bumper strike plate (figs. 1 & 8b).



3. Set the right (passenger side) assembly into position on the axle the same way the left side was positioned (fig. 1).
4. Raise the axle or lower the frame down so that the thick spacer (F) on the upper bracket is parallel to, and contacts the frame (on both sides).
5. Install the 3/8" Flat Washer (W) and a 3/8"-16 Nyloc nut (V) on the carriage bolt (M) that went through the existing jounce bumper hole and tighten securely on both sides (fig. 1).

CAUTION

BE SURE NOT TO PINCH THE PREVIOUSLY MOVED WIRING OR LINES INSIDE THE LEFT FRAME RAIL.

6. Cap the brace/upper bracket carriage bolts (P) with a 3/8" flat washer (W) and 3/8" nyloc nut (V) and tighten both securely on both sides.
7. With the spacers (F) on the upper brackets tight to the bottom of the frame and the braces tight to the upper bracket, tighten the 1/2 or 3/4" hardware previously installed, that hold the braces to the frame. Tighten both sides securely.
8. If so equipped with the emissions line previously loosened from the frame, insert the line holder post into the L-bracket (J) attached to the front or back leg of the upper left brace (B) (fig. 9). It may be necessary to move the line holder post forward or back on the lines to line up correctly with the L-bracket hole. Reattach any line holders removed forward or behind the axle, if possible, that were removed to aid in positioning the upper brace.

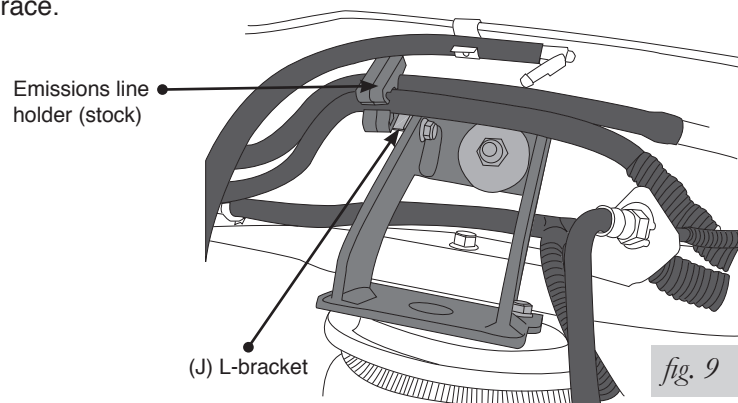

LOWER BRACKET ATTACHMENT

CAUTION

ATTACHING THE LOWER BRACKET WILL DEPEND ON THE MODEL TRUCK YOU HAVE. SEE FIGURE 10 TO DETERMINE WHICH HOLES TO USE FOR INSERTING THE CARRIAGE BOLTS.

1. Insert a 3/8-16 x 5.5 hex head bolt (K) and flat washer (W) into one of the two bottom holes of the locating bracket (I) (fig. 10).

NOTE

Use the hole that is closest to the leaf spring.

- 2a. If you are installing this kit on a single rear wheel (SRW) vehicle, use position 2 to insert the long 3/8-16 x 10" carriage bolt (Q) through the top of the locating bracket and lower bracket (fig. 10).
- 2b. If you are installing this kit on a dual rear wheel (DRW) vehicle, use position 1 to insert the long 3/8-16 x 10" carriage bolt (Q) through the top of the locating bracket and lower bracket (fig. 10).
3. Attach the locating bracket (I) to the lower bracket with a 3/8-16 x 1.25" carriage bolt (P), flat washer (W) and nyloc nut (V) using the remaining slot in the top of the locating bracket. Leave loose at this time.
4. Push the front and back locating brackets against the u-bolts and tighten the short carriage bolts at this time.
5. Using the 3/8-16 x 5.5 hex head bolts (K) and flat washers (W) previously installed on the locating brackets, insert them into the spring clamp bar (E) on the opposite side of the leaf spring assembly (fig. 11). Cap with 3/8" flat washers (W) and nyloc nuts (V). Leave loose at this time.

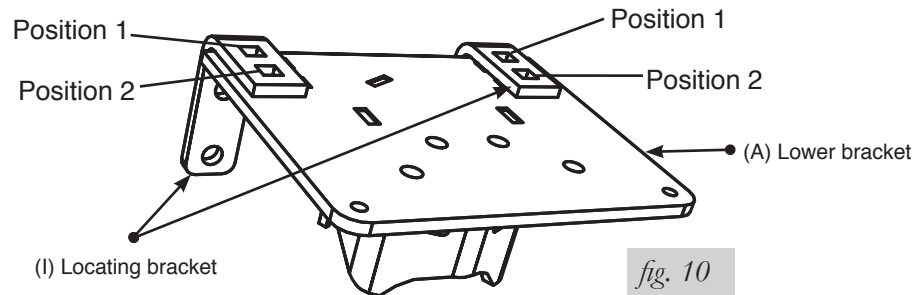

6. Set the axle clamp bar (D) onto the long 3/8-16 x 10" carriage bolts (Q) (fig. 1) and cap with 3/8" flat washers (W) and nyloc nuts (V).

NOTE

If you have a sway bar under the axle and the carriage bolt (Q) interferes, invert the carriage bolt.

7. Carefully draw the side hardware and axle hardware evenly. Torque the spring clamp bar bolts to 10 ft/lbs and the axle clamp bar bolts to 16 ft/lbs. Repeat for opposite side. Trim carriage bolts below nyloc nuts if necessary.

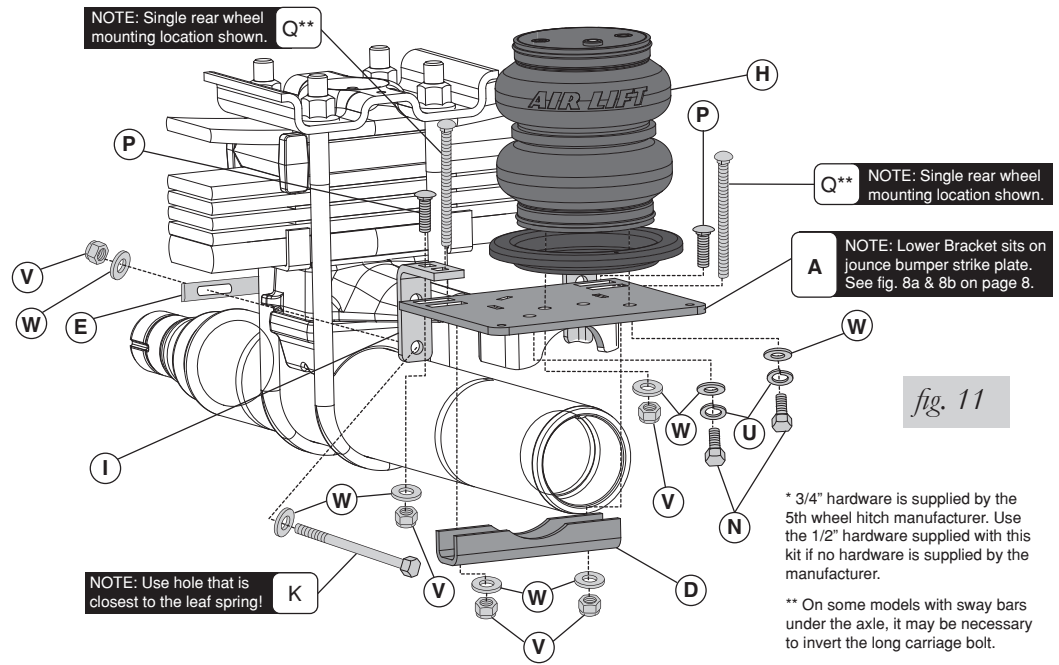

fig. 11

NOTE

For DRW vehicles, in order to install the sway bar and sway bar retaining straps back onto the axle, it will be necessary to slot the retaining straps (fig. 12). Reattach the sway bar once this is done.

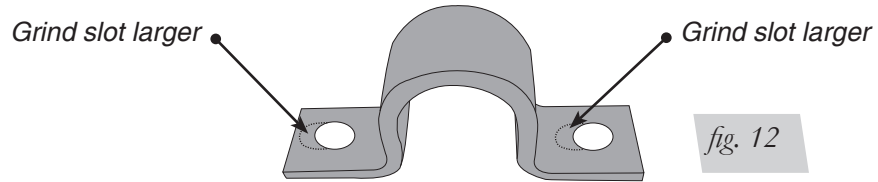

fig. 12

FINAL STEPS

1. The emergency brake cable will have to be re-located away from the bellows.

CAUTION

FAILURE TO DO SO MAY CAUSE FAILURE TO THE BELLOWS AND VOID THE WARRANTY.

2. Secure the emergency brake cable to the bottom bracket with supplied wire tie using the hole in the corner of the lower bracket (fig. 13).

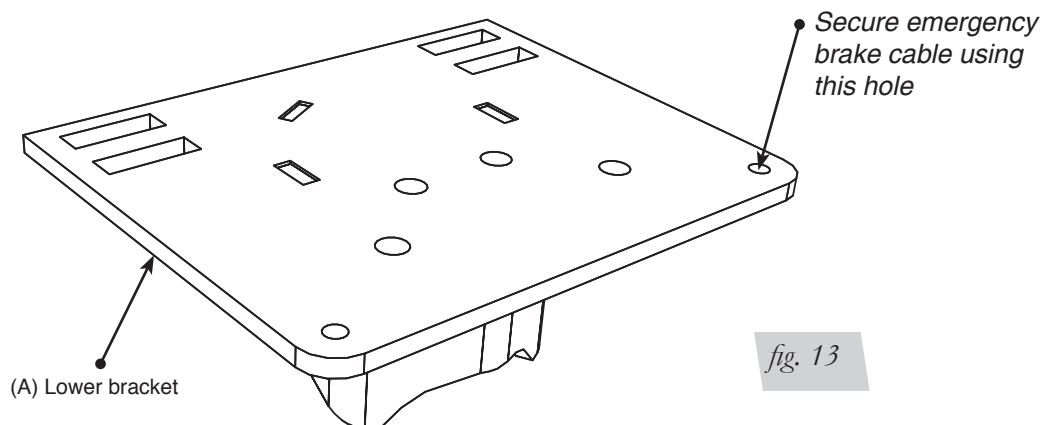

fig. 13

INSTALLING THE AIR LINES

1. Choose a convenient location for mounting the inflation valves. Popular locations for the inflation valve are:
 - a. The wheel well flanges
 - b. The license plate recess in bumper
 - c. Under the gas cap access door
 - d. Through the license plate

NOTE

Whatever the chosen location, make sure there is enough clearance around the inflation valves for an air chuck.

2. Drill two 5/16" holes to install the inflation valves.
3. Cut the air line assembly in two equal lengths.

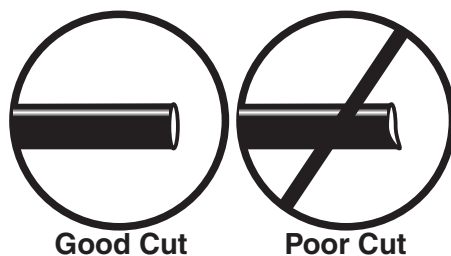

fig. 14



CAUTION

WHEN CUTTING OR TRIMMING THE AIR LINE, USE A HOSE CUTTER, A RAZOR BLADE, OR A SHARP KNIFE. A CLEAN, SQUARE CUT WILL ENSURE AGAINST LEAKS. DO NOT USE WIRE CUTTERS OR SCISSORS TO CUT THE AIR LINE. THESE TOOLS MAY FLATTEN OR CRIMP THE AIR LINE CAUSING IT TO LEAK AROUND THE O-RING SEAL INSIDE THE ELBOW FITTING (FIG. 14).

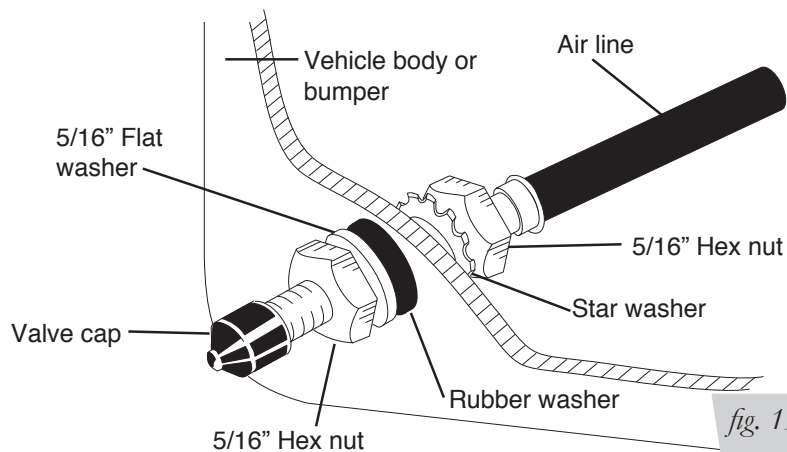
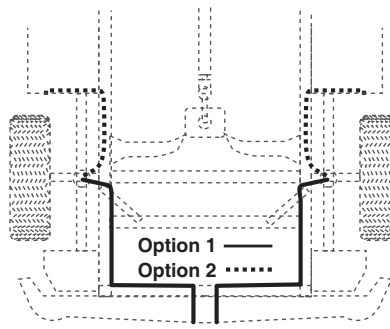

fig. 15

4. Place a 5/16" nut and star washer on the air valve. Leave enough of the inflation valve in front of the nut to extend through the hole and have room for the rubber washer, flat washer, and 5/16" nut and cap. There should be enough valve exposed after installation—approximately 1/2"— to easily apply a pressure gauge or an air chuck (fig. 15).
5. Push the inflation valve through the hole and use the rubber washer, flat washer, and another 5/16" nut to secure it in place. Tighten the nuts to secure the assembly.
6. Route the air line along the frame to the air fitting on the air spring (fig. 16). Keep AT LEAST 6" of clearance between the air line and heat sources, such as the exhaust pipes, muffler, or catalytic converter. Avoid sharp bends and edges. Use the plastic tie straps to secure the air line to fixed, non-moving points along the chassis. Be sure that the tie straps are tight, but do not pinch the air line. Leave at least 2" of slack to allow for any movement that might pull on the air line.

fig. 16

7. Cut off the air line, leaving approximately 12" of extra air line. A clean square cut will ensure against leaks. Insert the air line into the air fitting. This is a push-to-connect fitting. Simply push the air line into the 90° swivel fitting until it bottoms out (9/16" of air line should be in the fitting).

INSTALLING THE HEAT SHIELD

1. Bend tabs to provide a 1/2" dead air space between exhaust pipe and heat shield (fig. 17).
2. Attach the heat shield to the exhaust pipe using the clamps. Bend the heat shield for maximum clearance to the air spring (fig. 18).

NOTE

Some vehicles have large resonators in this area, it will be necessary to double up on the clamps to fit these models (fig. 18).

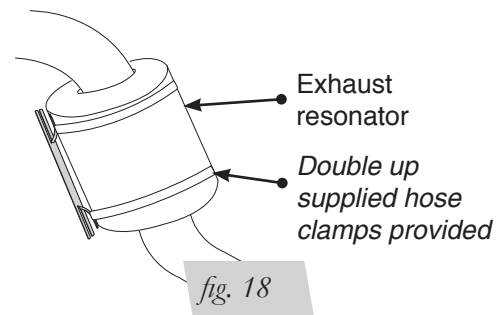
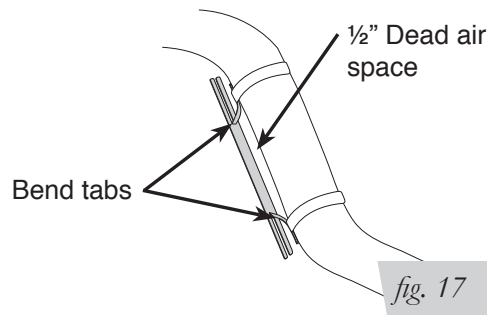

CHECKING FOR LEAKS

1. Inflate the air spring to 30 PSI.
2. Spray all connections and the inflation valves with a solution of 1/5 liquid dish soap and 4/5 water. Spot leaks easily by looking for bubbles in the soapy water.
3. After the test, deflate the springs to the minimum pressure required to restore the system to normal ride height. Do not deflate to lower than 5 PSI.
4. Check the air pressure again after 24 hours. A 2 - 4 PSI loss after initial installation is normal. Retest for leaks if the loss is more than 5 lbs.

FIXING LEAKS

1. If there is a problem with the swivel fitting:
 - a. Check the air line connection by deflating the spring and removing the line by pulling the collar against the fitting and pulling firmly on the air line. Trim 1" off the end of the air line. Be sure the cut is clean and square (see fig. 14). Reinsert the air line into the push-to-connect fitting.
 - b. Check the threaded connection by tightening the swivel fitting another 1/2 turn. If it still leaks, deflate the air spring, remove the fitting, and re-coat the threads with thread sealant. Reinstall by hand tightening as much as possible and then use a wrench for an additional two turns.

2. If there is a problem with the inflation valve:
 - a. Check the valve core by tightening it with a valve core tool.
 - b. Check the air line by removing the air line from the barbed type fitting. Cut the air line off a few inches in front of the fitting and use a pair of pliers or vice grips to pull/twist the air line off of the fitting.

 **CAUTION**

DO NOT CUT OFF THE AIR LINE COMPLETELY AS THIS WILL USUALLY NICK THE BARB AND RENDER THE FITTING USELESS.

3. If the preceding steps have not resolved the problem, call Air Lift customer service at (800) 248-0892.

Before Operating

INSTALLATION CHECKLIST (To be completed by installer)

- Clearance test — Inflate the air springs to 60 PSI and ensure there is at least ½" clearance around each bellow, away from anything that might rub against them. Be sure to check the tire, brake drum, frame, shock absorbers and brake cables.
- Leak test before road test — Inflate the air springs to 60 PSI, check all connections for leaks with a soapy water solution. See page 12 for tips on how to spot leaks. All leaks must be eliminated before the vehicle is road tested.
- Heat test — Be sure there is sufficient clearance from any heat sources — at least 6" for air springs and air lines. If a heat shield was included in the kit, install it. If there is no heat shield, but one is required, call (800) 248-0892.
- Fastener test — Recheck all bolts for proper torque. Axle clamp bar carriage bolt lock nuts should be torqued to 16 ft/lbs. Re-torque after 100 miles.
- Road test — The vehicle should be road tested after the preceding tests. Inflate the air springs to 25 PSI (50 PSI if the vehicle is loaded). Drive the vehicle 10 miles and recheck for clearance, loose fasteners and air leaks.
- Operating instructions — If professionally installed, the installer should review the Product Use, Maintenance and Servicing section on page 14 with the owner. Be sure to provide the owner with all of the paperwork which came with the kit.

Technician's Signature _____

Date _____

POST-INSTALLATION CHECKLIST

- Overnight leak down test — Recheck air pressure after the vehicle has been used for 24 hours. If the pressure has dropped more than 5 PSI, then there is a leak that must be fixed. Either fix the leak yourself or return to the installer for service.
- Air pressure requirements — I understand the air pressure requirements of my air spring system. Regardless of load, the air pressure should always be adjusted to maintain ride height at all times.
- Thirty day or 500 mile test — I understand that I must recheck the air spring system after 30 days or 500 miles, whichever comes first. If any part shows signs of rubbing or abrasion, the source should be identified and moved, if possible. If it is not possible to relocate the cause of the abrasion, the air spring may need to be remounted. If professionally installed, the installer should be consulted. Check all fasteners for tightness.

Product Use, Maintenance and Servicing

Minimum Pressure	Maximum Air Pressure
5 PSI	100 PSI
FAILURE TO MAINTAIN CORRECT MINIMUM PRESSURE (OR PRESSURE PROPORTIONAL TO LOAD), BOTTOMING OUT, OVER-EXTENSION OR RUBBING AGAINST ANOTHER COMPONENT WILL VOID THE WARRANTY.	

MAINTENANCE GUIDELINES

NOTE

By following the steps below, vehicle owners will obtain the longest life and best results from their air springs.

1. Check the air pressure weekly.
2. Always maintain normal ride height. Never inflate beyond 100 PSI.
3. If you develop an air leak in the system, use a soapy water solution (1/5 liquid dish soap and 4/5 water) to check all air line connections and the inflation valve core before deflating and removing the air spring.

CAUTION

FOR YOUR SAFETY AND TO PREVENT POSSIBLE DAMAGE TO YOUR VEHICLE, DO NOT EXCEED MAXIMUM GROSS VEHICLE WEIGHT RATING (GVWR), AS INDICATED BY THE VEHICLE MANUFACTURER. ALTHOUGH YOUR AIR SPRINGS ARE RATED AT A MAXIMUM INFLATION PRESSURE OF 100 P.S.I., THE AIR PRESSURE ACTUALLY NEEDED IS DEPENDANT ON YOUR LOAD AND GVWR.

4. Loaded vehicles require at least 25 PSI or more. A “loaded vehicle” refers to a vehicle with a heavy bed load, a trailer, or both. As discussed above, never exceed GVWR, regardless of air spring, air pressure, or other load assist. The springs in this kit will support approximately 40 lbs. of load (combined on both springs) for each 1 PSI of pressure. The required air pressure will vary depending on the state of the original suspension. Operating the vehicle below the minimum air spring pressure will void the Air Lift warranty.
5. When increasing load, always adjust the air pressure to maintain the normal ride height. Increase or decrease pressure from the system as necessary to attain normal ride height for optimal ride and handling. Remember that loads carried behind the axle (including tongue loads) require more leveling force (pressure) than those carried directly over the axle.
6. Always add air to springs in small quantities, checking the pressure frequently.
7. Should it become necessary to raise the vehicle by the frame, make sure the system is at minimum pressure (5 PSI) to reduce the tension on the suspension/brake components. Use of on board leveling systems do not require deflation or disconnection.
8. Periodically check the air spring system fasteners for tightness. Also, check the air springs for any signs of rubbing. Realign if necessary.
9. On occasion, give the air springs a hard spray with a garden hose in order to remove mud, sand, gravel or other abrasive debris.

Troubleshooting Guide

1. Leak test the air line connections, the threaded connection into the air spring, and all fittings in the control system.
2. Inspect the air lines to be sure none are pinched. Tie straps may be too tight. Loosen or replace the strap and replace leaking components.

3. Inspect the air line for holes and cracks. Replace as needed.
4. Look for a kink or fold in the air line. Reroute as needed.

If the preceding steps do not solve the problem, it is possibly caused by a failed air spring — either a factory defect or an operating problem. Please call Air Lift at (800) 248-0892 for assistance.

Frequently Asked Questions

Q. Will installing air springs increase the weight ratings of a vehicle?

No. Adding air springs will not change the weight ratings (GAWR, GCWR and/or GVWR) of a vehicle. Exceeding the GVWR is dangerous and voids the Air Lift warranty.

Q. Is it necessary to keep air in the air springs at all times and how much pressure will they need?

The minimum air pressure should be maintained at all times. The minimum air pressure keeps the air spring in shape, ensuring that it will move throughout its travel without rubbing or wearing on itself.

Q. Is it necessary to add a compressor system to the air springs?

No. Air pressure can be adjusted with any type of compressor as long as it can produce sufficient pressure to service the springs. Even a bicycle tire pump can be used, but it's a lot of work.

Q. How long should air springs last?

If the air springs are properly installed and maintained they can last indefinitely.

Q. Will raising the vehicle on a hoist for service work damage the air springs?

No. The vehicle can be lifted on a hoist for short-term service work such as tire rotation or oil changes. However, if the vehicle will be on the hoist for a prolonged period of time, support the axle with jack stands in order to take the tension off of the air springs.

Tuning the Air Pressure

Pressure determination comes down to three things — level vehicle, ride comfort, and stability.

1. Level vehicle

If the vehicle's headlights are shining into the trees or the vehicle is leaning to one side, then it is not level (fig. 19). Raise the air pressure to correct either of these problems and level the vehicle.

2. Ride comfort

If the vehicle has a rough or harsh ride it may be due to either too much pressure or not enough (fig. 20). Try different pressures to determine the best ride comfort.

3. Stability

Stability translates into safety and should be the priority, meaning the driver may need to sacrifice a perfectly level and comfortable ride. Stability issues include roll control, bounce, dive during braking and sponginess (fig. 21). Tuning out these problems usually requires an increase in pressure.



Bad headlight aim

fig. 19



Rough ride

fig. 20

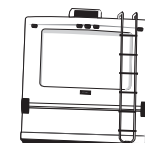

Sway and
body roll

fig. 21

Guidelines for Adding Air

1. Start with the vehicle level or slightly above.
2. When in doubt, always add air.
3. For motorhomes, start with 50-100 PSI in the rear because it can be safely assumed that it is heavily loaded.
4. If the front of the vehicle dives while braking, increase the pressure in the front air bags, if equipped.
5. If it is ever suspected that the air bags have bottomed out, increase the pressure (fig. 22).
6. Adjust the pressure up and down to find the best ride.
7. If the vehicle rocks and rolls, adjust the air pressure to reduce movement.
8. It may be necessary to maintain different pressures on each side of the vehicle. Loads such as water, fuel, and appliances will cause the vehicle to be heavier on one side (fig. 23). As much as a 50 PSI difference is not uncommon.



Bottoming out

fig. 22

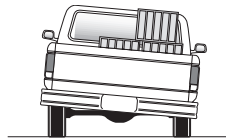

Unlevel

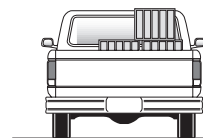

Level

fig. 23

Warranty and Returns Policy

Air Lift Company warrants its products, for the time periods listed below, to the original retail purchaser against manufacturing defects when used on catalog-listed applications on cars, vans, light trucks and motorhomes under normal operating conditions for as long as Air Lift manufactures the product. The warranty does not apply to products that have been improperly applied, improperly installed, used in racing or off-road applications, used for commercial purposes, or which have not been maintained in accordance with installation instructions furnished with all products. The consumer will be responsible for removing (labor charges) the defective product from the vehicle and returning it, transportation costs prepaid, to the dealer from which it was purchased or to Air Lift Company for verification.

Air Lift will repair or replace, at its option, defective products or components. A minimum \$10.00 shipping and handling charge will apply to all warranty claims. Before returning any defective product, you must call Air Lift at (800) 248-0892 in the U.S. and Canada (elsewhere, (517) 322-2144) for a Returned Materials Authorization (RMA) number. Returns to Air Lift can be sent to: Air Lift Company • 2727 Snow Road • Lansing, MI • 48917.

Product failures resulting from abnormal use or misuse are excluded from this warranty. The loss of use of the product, loss of time, inconvenience, commercial loss or consequential damages is not covered. The consumer is responsible for installation/reinstallation (labor charges) of the product. Air Lift Company reserves the right to change the design of any product without assuming any obligation to modify any product previously manufactured.

This warranty gives you specific legal rights and you may also have other rights that vary from state-to-state. Some states do not allow limitations on how long an implied warranty lasts or allow the exclusion or limitation of incidental or consequential damages. The above limitation or exclusion may not apply to you. There are no warranties, expressed or implied including any implied warranties of merchantability and fitness, which extend beyond this warranty period. There are no warranties that extend beyond the description on the face hereof. Seller disclaims the implied warranty of merchantability. (Dated proof of purchase required.)

(Warranty & Returns Policy continued)

Air Lift 1000	Lifetime Limited	LoadController/Dual	2 Year Limited
RideControl	Lifetime Limited	Load Controller (I)	2 Year Limited
LoadLifter 5000*	Lifetime Limited	Load Controller (II)	2 Year Limited
SlamAir	Lifetime Limited	SmartAir	2 Year Limited
AirCell	Lifetime Limited	Wireless AIR	2 Year Limited
Air Lift Performance**	1 Year Limited	WirelessONE	2 Year Limited
LoadController/Single	2 Year Limited	Other Accessories	2 Year Limited

**formerly SuperDuty
**formerly LifeSTYLE & Performance*

Replacement Information

If you need replacement parts, contact the local dealer or call Air Lift customer service at (800) 248-0892. Most parts are immediately available and can be shipped the same day.

Contact Air Lift Company customer service at (800) 248-0892, first if:

- Parts are missing from the kit.
- Need technical assistance on installation or operation.
- Broken or defective parts in the kit.
- Wrong parts in the kit.
- Have a warranty claim or question.

Contact the retailer where the kit was purchased:

- If it is necessary to return or exchange the kit for any reason.
- If there is a problem with shipping if shipped from the retailer.
- If there is a problem with the price.

Contact Information

If you have any questions, comments or need technical assistance, contact our customer service department by calling (800) 248-0892, Monday through Friday, 8 a.m. to 7 p.m. Eastern Time. For calls from outside the USA or Canada, our local number is (517) 322-2144.

For inquiries by mail, our address is PO Box 80167, Lansing, MI 48908-0167. Our shipping address for returns is 2727 Snow Road, Lansing, MI 48917.

You may also contact us anytime by e-mail at sales@airliftcompany.com or on the web at www.airliftcompany.com.

Need Help?

Contact our customer service department by calling (800) 248-0892, Monday through Friday, 8 a.m. to 7 p.m. Eastern Time. For calls from outside the USA or Canada, our local number is (517) 322-2144.

**Register your warranty online at
www.airliftcompany.com/warranty**



Thank you for purchasing Air Lift products — the professional installer's choice!

Air Lift Company • 2727 Snow Road • Lansing, MI 48917 or PO Box 80167 • Lansing, MI 48908-0167
Toll Free (800) 248-0892 • Local (517) 322-2144 • Fax (517) 322-0240 • www.airliftcompany.com

Printed in
the USA