

2014 & UP - RAM 1500 DIESEL (USE WITH 30035 KIT)



Read pages 2-3 of 30035 instructions before starting installation. Failure to do so could result in significant vehicle damage!

IMPORTANT NOTES FOR THIS INSTALLATION:

1. Tube spacer and 4 1/2" carriage bolt used to attach through forward Bed Sill (Row 2).
2. **Rib neck bolts will need to be pulled through access holes in frame with supplied pull wire (see below).
3. Install edge protector on curved edge of forward driver's side bracket prior to install.

3. Do not drill thru both walls of frame. Drill only thru wall of frame to which bracket is mounted.

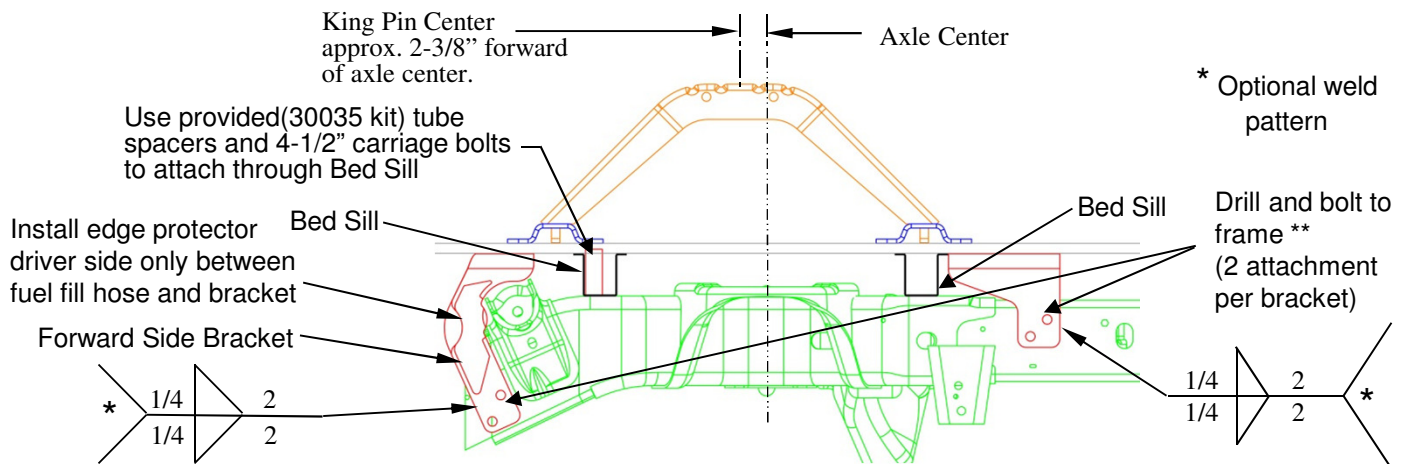
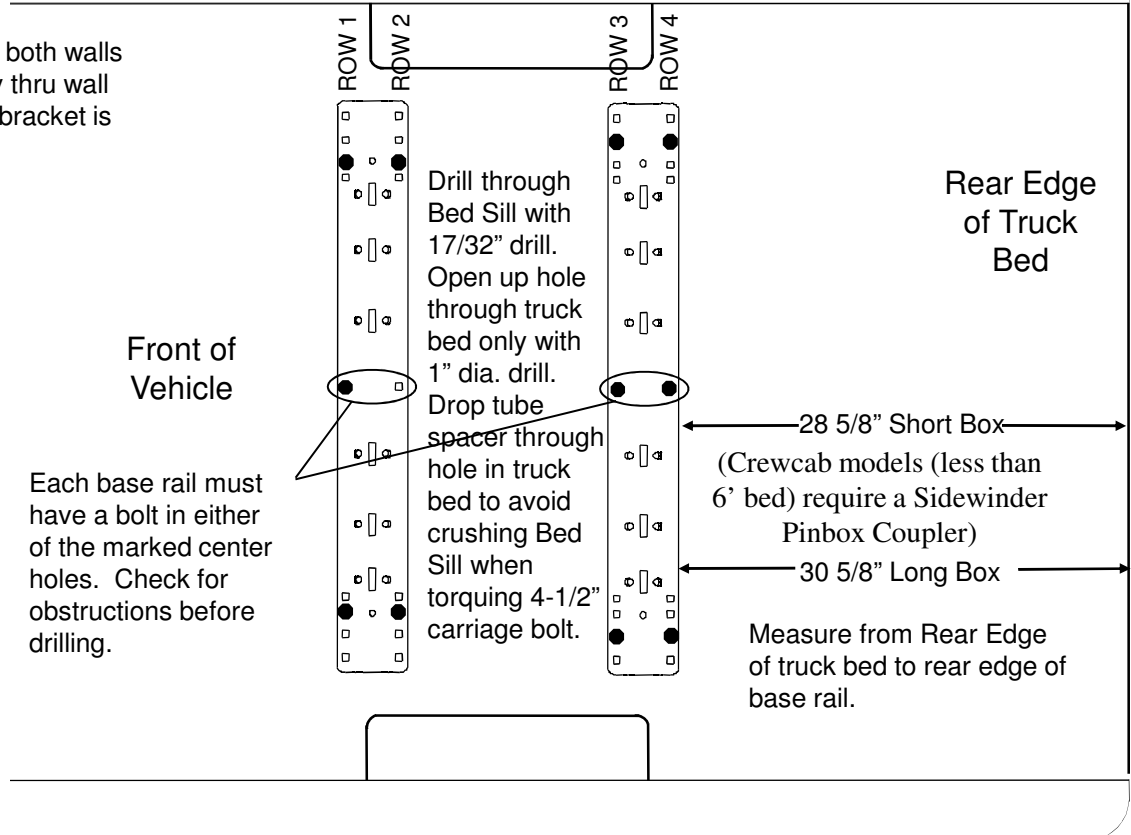

Check for obstructions before drilling. Failure to do so could result in damaged fuel or brake lines, structural members, etc. TOWING PRODUCTS does its best to communicate tow vehicle manufacturer changes; however, it is ultimately the responsibility of the installer to prevent damage due to installation.