

**C-615**

**GOOSENECK HITCH**

Parts List			
ITEM	QTY	PART NUMBER	DESCRIPTION
1	2	CM-C60-CLA	SAFETY CHAIN LOOP ASSEMBLY
1.1	1	CM-C60-CL	2" x 3" SAFETY CHAIN LOOP
1.2	2	CM-C60-S	U-BOLT SPRING
1.3	2	1_2 - 13	NYLOCK HEX NUT
1.4	4	FW12SAE	FW,1/2 SAE,ZP
2	2	3/8"	WASHER
3	1	#10-24 x 1.25 HHFS	HEX HEAD FLANGE SCREW
4	1	#10-24 NYLOCK HEX NUT	NYLOCK HEX NUT
5	3	#10-32 x 3/4	FLAT HEAD C'SUNK CAP SCREW
6	1	CM-C60-R	.375" HANDLE ROD
7	1	CM-C60-CS	7.5 LB COMPRESSION SPRING
8	1	CM-C60-H	VINYL HANDLE GRIP
9	1	CM-C60-RC	RUBBER COVER
10	1	CM-C60-B	TURNOVER BALL COMPLETE
11	1	CM-C600-CLP	CAST LOCK PIN
12	1	CM-C600-CR	3.75 DIA. x .375" CHROME RING
13	1	CM-UE1	.300" U-SHAPED EDGING

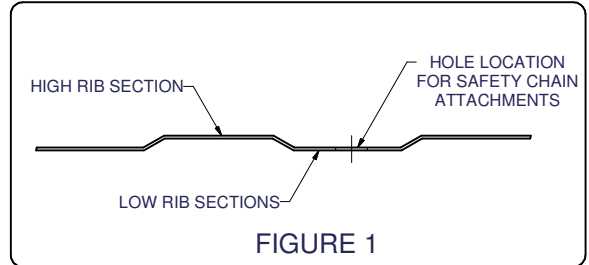
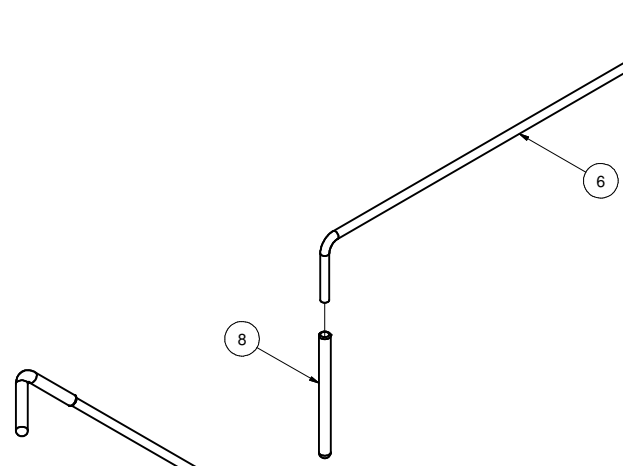
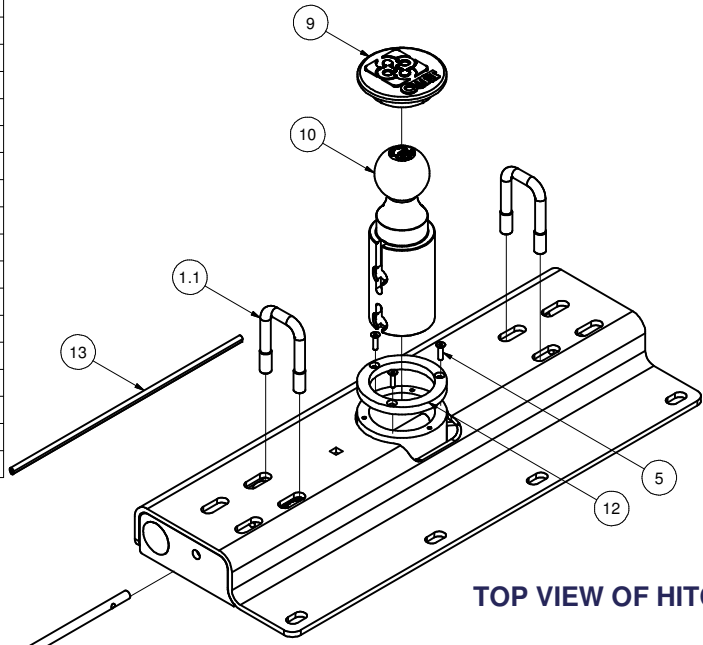

**BOTTOM VIEW OF HITCH**

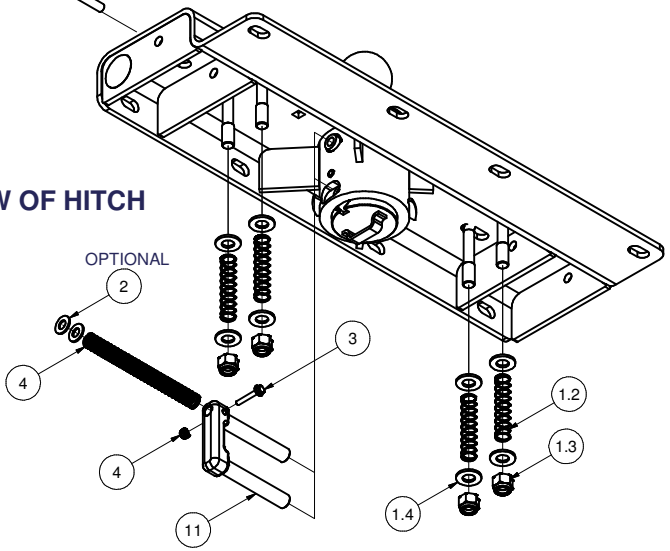

Curt Manufacturing Inc., warrants this product to be free of defects in material and/or workmanship at the time of retail purchase by the original purchaser. If the product is found to be defective, Curt Manufacturing Inc., may repair or replace the product, at their option, when the product is returned, prepaid, with proof of purchase. Alteration to, misuse of, or improper installation of this product voids the warranty. Curt Manufacturing Inc.'s liability is limited to repair or replacement of products found to be defective, and specifically excludes liability for incidental or consequential loss or damage.

**Warning!!** Carefully examine the location of fuel lines, brake lines, and electrical wires BEFORE INSTALLATION. Brake, fuel, and electrical lines may need to be loosened or repositioned to provide clearance for new hardware. The installation of this hitch may require modification or removal of heat shields. The use of overload springs, air bags, etc. may be required when towing heavy loads.

### Installing C-615 Turnover Gooseneck After Cross Arm Sub-kit Installation

- 1) Install rubber edging (CM-UE1) on cut edge for C-615 cylinder, trim excess.
- 2) Position the C-615 over the rear axle and up to the rear cross arm with the cylinder facing the correct direction for decided application. Install four 1/2" x 1 3/4" carriage bolts into the C-615 first, then through the rear cross arm and secure with 1/2" flange nuts, finger tighten.
- 3) Move the front cross arm to the C-615 and install the 1/2" x 1 3/4" carriage bolts into the cross arm then through the C-615 and secure with 1/2" flange nuts.
- 4) Torque all 1/2" hardware to 110 ft-lbs.

### Installing Safety Chain Attachments

- 1) From under the truck use the C-615 gooseneck as a template to drill four 1/2" holes for the safety chain attachments.
- 2) Using a 1/2" drill bit, drill the center of each slotted hole in the gooseneck. **(Note: Be sure the holes are drilled in the lower rib section of the truck bed as shown in FIGURE 1).**
- 3) From inside the truck box place the two U-bolts through the predrilled holes in the bed of the truck.
- 4) From beneath the truck place a spring and nylock nut on each of the four U-bolt legs. Tighten the nylock nuts until flush with the bottom of the U-bolt.

### Installing handle / lock

- 1) Insert Locking Pin (7) into the ball cylinder with handle rod hole located on top.
- 2) Slide foam grip (10) onto handle rod.
- 3) Insert handle rod from outside vehicle, through the hole in the C-615 endplate, and through the rod guide as shown. (Handle rod may be installed on driver side or passenger side, depending on preference).
- 4) Slide the compression spring (8) over handle rod before inserting the handle rod into the locking pin. Insert handle rod into locking pin and secure with #10 screw (5) and nylock nut (4) as shown. **(Note: Use 1-2 additional 3/8" washers (6) as needed to ensure proper pull length of locking pin).**

### Caution!!!

1. Check that all 1/2" hardware has been torqued to 75 ft-lbs (12 - 1/2" Flange Nuts total)
2. Check that all side plate hardware has been torqued. Some hardware listed will not apply to your application.
  - 3/8" to 45 ft-lbs.
  - 1/2" to 110 ft-lbs.
  - 5/8" to 210 ft-lbs.
  - 3/4" to 300 ft-lbs.
  - 1" to 300 ft-lbs.
3. Re-attach Brake, Fuel, and Electrical lines so they do not contact any of the added fasteners.

### C-615 Operation

1. Pull the handle out as far as possible and rotate clockwise until the locking pin is disengaged and locked out.
2. Insert ball in the tow position into the cylinder by aligning the ball groove with the cylinder pin. If the groove and pin are not aligned simply rotate ball until the ball drops into place.
3. Rotate handle counter clockwise until locking pin snaps back into position. (Note: Be certain the locking pin passes completely through the ball and securely into the cylinder.)

### C-615 Installation check

1. Set ball in towing position and handle in locked position.
2. Connect the trailer to the hitch ball.
3. Check truck box clearance, there should be a minimum clearance of 6" between the bottom of the trailer overhang and the top of the box sides. Verify clearance between the truck and trailer at cab and box corners.

### Maintenance (Required every 30 days or prior to use)

1. Keep hitch ball lubricated regularly. Use silicone spray or equivalent to prevent wear and rust.
2. Keep hitch assembly free of dirt and other foreign debris.
3. Check for proper torque on all nuts and bolts before each use. Also check for excessive wear.
4. Check for ball wear before each use. **(Note: Do not tow trailer with worn or damaged parts).**

\*\*\*DO NOT EXCEED VEHICLE MANUFACTURER'S RECOMMENDED TOWING

CAPACITY.\*\*\*

## CAB TO TRAILER CLEARANCE

\*\*REMOVAL OF REAR WINDOW ACCESSORIES MAY BE REQUIRED.\*\*

### TRAILER

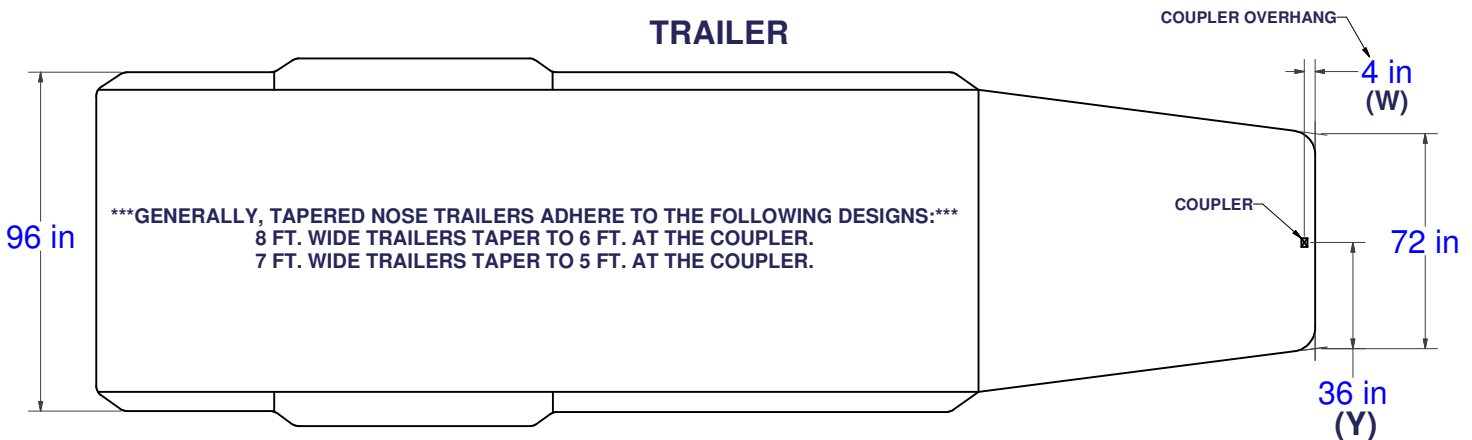

### LONG & SHORT TRUCK BEDS

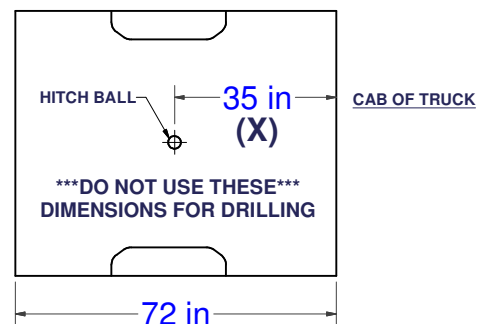
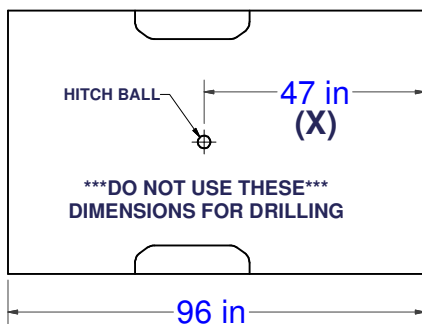

### CLEARANCE CALCULATION

$$\begin{matrix} \text{(CAB TO BALL CENTER)} & - & 1/2 \text{ (TRAILER WIDTH)} & = & \text{(MINIMUM CLEARANCE)} \\ \text{(X)} & - & \text{(Y)} & = & \text{(Z)} \end{matrix}$$

IF THERE IS AN OVERHANG FROM THE COUPLER THEN THE EQUATION IS:

$$\text{[(X) - (W)]} - \text{(Y)} = \text{(Z)}$$

\*\*\*IF (Z) IS POSITIVE, TRAILER **WILL NOT** INTERFERE WITH CAB OF TRUCK.\*\*\*  
 IF (Z) IS NEGATIVE, TRAILER **WILL** INTERFERE WITH CAB OF TRUCK!!!

#### EXAMPLE:

##### STANDARD TRAILER

$$X - Y = Z$$

$$35 - 36 = -1$$

(TRAILER **WILL INTERFERE** WITH CAB)

##### TRAILER WITH OVERHANG

$$\text{[(X) - (W)]} - Y = Z$$

$$[35 - 4] - 36 = -5$$

(TRAILER **WILL INTERFERE** WITH CAB)

#### YOUR CALCULATION:

(CAB TO BALL CENTER) \_\_\_\_\_

(COUPLER OVERHANG) - \_\_\_\_\_

1/2 (TRAILER WIDTH) - \_\_\_\_\_

(MINIMUM CLEARANCE) = \_\_\_\_\_

**60632****CHEVY / GMC 1500 SILVERADO / SIERRA NEW BODY ONLY - ALL BEDS****"THIS IS TO BE USED WITH C-615 CENTERS ONLY, 2007 TO CURRENT 1500 TRUCKS"**

**WARNING!!** BRAKE, FUEL, AND ELECTRICAL LINES MAY NEED TO BE LOOSENED OR REPOSITIONED TO PROVIDE CLEARANCE FOR NEW HARDWARE. ALL MODELS REQUIRE MODIFICATION OR REMOVAL OF HEAT SHIELDS. ON SHORT BED MODELS, CHECK FOR ADEQUATE TURNING CLEARANCE BETWEEN THE FRONT OF ALL TRAILERS AND THE TRUCK CAB.

**WARNING!!** ON TWO WHEEL DRIVE TRUCKS A CLEARANCE CHECK MUST BE PERFORMED WHEN TRUCK IS LOADED AND UNLOADED TO VERIFY THE INVERTED BALL WILL NOT INTERFERE WITH THE TOP OF THE DIFFERENTIAL

**INSTALLATION STEPS****\*\*REMOVE ALL REAR WINDOW ACCESSORIES BEFORE TOWING\*\*****BEFORE INSTALLING**

An overhead lifting device, such as chain falls, engine hoist, or cable come-a-long, can be used to lift the center section of the hitch in place. Lower a loop of rope or chain through the hole in the truck bed floor and attach it to the round hitch receiver tube in the center section. Use the lifting device to raise the center section until the round hitch receiver tube that protrudes from the center section fits in the hole in the truck bed floor. Maintaining upward pressure may facilitate fastening the cross-member to the center section, especially if the truck bed floor has been distorted downward from heavy use. If you use an overhead-lifting device, it should be disconnected before squaring the center section across the frame, installing the sideplates and torquing fasteners.

- 1) Remove spare tire and heat shield. The heat shield under the bed floor needs to be removed or a section cut out for the hitch assembly to be installed. First, remove the heat shield from in front of the back crossmember. Next, remove the heat shield from the back of the crossmember located near the front of the wheel well.
- 2) Mark the location for the hole in the truck bed. Measure from the tail gate end of the truck bed, by hooking a tape measure over the **back of the truck box** and marking the correct location. **(NOTE: DO NOT MEASURE FROM EDGE OF TAILGATE)** Next, mark the center between the wheel wells. This marks the center point for the drill hole. This hole location is critical for the correct installation of this hitch. Measure, mark, and saw carefully. This location will put the ball 4"-6" in front of the axle.

<b>69.30" Bed Installation</b>	<b>42 7/16"</b>
<b>78.70" Bed Installation</b>	<b>42 7/16"</b>
<b>97.60" Bed Installation</b>	<b>49 1/2"</b>

**NOTE:** If truck has a plastic bed liner, you may drill through both, but it is more difficult to accurately locate the midpoint between the wheel wells and to keep the bed liner from moving while cutting the hole. Make a 4" hole at this location using a 4" hole saw, or by making a 4" circle and cutting it out with a saber saw equipped with a metal cutting blade.

		Parts List	
ITEM	QTY	PART NUMBER	DESCRIPTION
1	4	CM-SP13	2.50 DIA. x .250" ROUND HOLE SPACER
2	2	CM-1206-UBS	1/2-13 x 4 1/8 x 4 3/4 x 1 1/2 SQ U-BOLT
3	2	CM-1208-UBS	1/2-13 x 4 1/8 x 6 x 1 1/2 SQ U-BOLT
4	4	HFN 1213	HEX FLANGE NUT
5	12	1/2 - 13 x 1 1/2	HEX BOLT
6	12	FW12	FW, 12, ZP
7	12	1/2"	LOCK WASHER
8	2	M8-1.25	HEX FLANGE NUT
9	2	M8 - 1.25 x 20	HEX BOLT
10	2	3_4 - 10 x 5 1_2 HEX	HEX BOLT
11	2	3_4 FW	FLAT WASHER
12	2	3_4 - 10 HFN	HEX FLANGE NUT
13	2	CM-SP58	.250 x 3.00 x 4.00" SPACER
14	1	CM-BLB	11GA. BRAKE LINE BRACKET

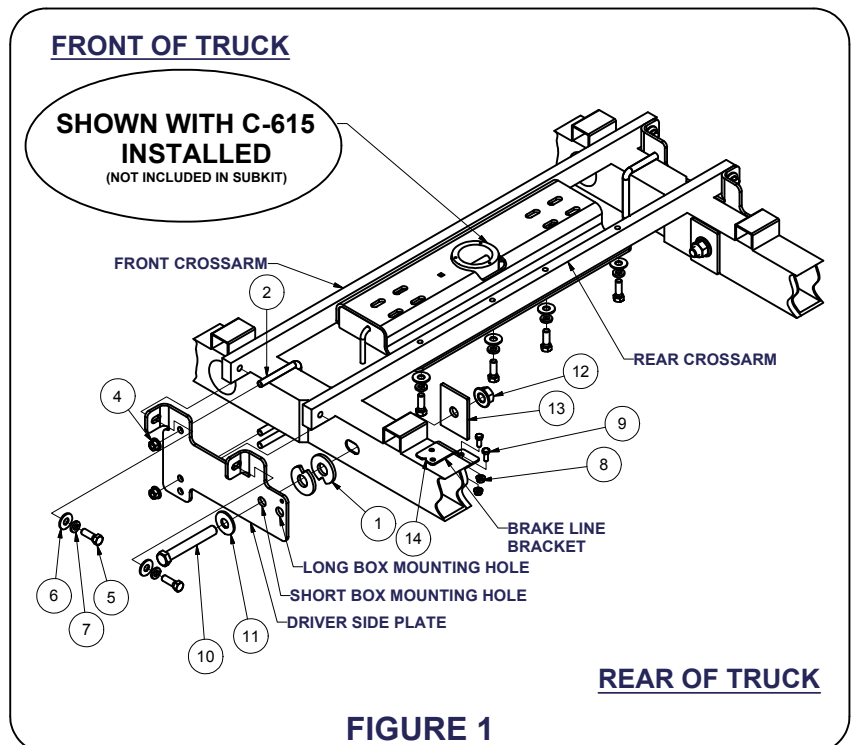

Curt Manufacturing Inc., warrants this product to be free of defects in material and/or workmanship at the time of retail purchase by the original purchaser. If the product is found to be defective, Curt Manufacturing Inc., may repair or replace the product, at their option, when the product is returned, prepaid, with proof of purchase. Alteration to, misuse of, or improper installation of this product voids the warranty. Curt Manufacturing Inc.'s liability is limited to repair or replacement of products found to be defective, and specifically excludes liability for incidental or consequential loss or damage.

**\*\*DO NOT EXCEED RECOMMENDED VEHICLE TOWING WEIGHT!\*\***

**60632**

**CHEVY / GMC 1500 SILVERADO / SIERRA NEW BODY ONLY - ALL BEDS**

**\*\*REMOVE ALL REAR WINDOW ACCESSORIES BEFORE TOWING\*\***

### **INSTALLATION STEPS CONTINUED**

- 3) Remove all lines from top of frame rail on driver side. Lower the brake lines by unbolting factory brake line bracket and replace with Curt supplied bracket by using existing bolts, then attach factory bracket to Curt bracket using supplied 8MM bolts and nuts.
- 4) Install the rear cross arm by sliding it between the frame and truck bed floor above the passenger side rear tire. After spanning the frames, rotate the cross arm vertically with the (4) center threaded holes towards the ground. **On short bed applications**, the location of the cross arm should be behind the bed rail support towards the rear of the truck. **Note:** If vehicle is equipped with wheel well liners they may need to be temporarily removed for cross arm installation.
- 5) Install the front cross arm by sliding it between the truck frame and truck bed above the passenger side rear tire. With the cross arm spanning the truck frame, rotate it vertically with the holes towards the bottom. **On Short bed applications**, the cross arm will be located in front of the bed rail support towards the rear of the truck. Once vertical, slide the cross arm up against the bed rail support.
- 6) Install the center section by carefully raising it above the fuel tank from beneath the truck. Insert four 1/2" x 1 1/2" hex bolts with a washer and lock washer through each of the slots on the inside of the center section, and thread them finger tight into the front cross arm. Repeat that process for the rear cross arm. While installing the center section, be sure that the round hitch cylinder that protrudes from the top of the center section fits into the hole in the bed of the truck.
- 7) Install the sideplates with the large hole towards the back of the truck aligning them with the existing slot in the frame. Refer to **Figure 1** on page 1 for directions on which mounting plate hole to use. Attach using a 3/4-10 x 5 1/4" hex bolt and 3/4" washer, pushing it through the frame while putting (2) CM-SP13 spacers on the bolt between the frame and the sideplate, then attach the sideplate with a CM-SP58 spacer and a 3/4" flange nut. **Finger tight** both sides. With the sideplates mounted at the slot, attach the flanges to the cross arms using two 1/2" x 1 1/2" hex bolts with 1/2" washers and 1/2" lock washers. Thread them through the inside of the sideplate flanges into the cross arms. **(Finger tight only!)**
- 8) Finish attaching sideplates to the frame using the provided U-bolts. **For long box applications**, use the larger U-bolt. The smaller U-bolt is used on the short box applications. Position the U-bolt from the inside of the truck frame, make sure not to damage or pinch the wiring harness or brake lines. Attach to the sideplate using two 1/2" flange nuts. **(Finger tight only)**
- 9) With the sideplates installed on both sides, torque all 1/2" fasteners to 110 ft-lbs, and 3/4" fasteners to 380 ft-lbs in the following order:  
**First:** Torque the center section to the front and rear cross arms.  
**Second:** Torque the sideplates to the truck frame on both sides. **(When torquing the U-bolts, make sure to tighten them slowly alternating between the top and bottom of the U-bolt until equally tightened to maximum of 40 ft-lbs.)**  
**Third:** Torque the sideplate flanges to the front and rear cross arms.

**(REFER TO GOOSENECK HITCH INSTRUCTIONS FOR INSTALLATION AND OPERATION PROCEDURES)**

### **Maintenance (Required every 30 days or prior to use)**

1. Keep hitch ball lubricated regularly. Use silicone spray or equivalent to prevent wear and rust.
2. Keep hitch assembly free of dirt and other foreign debris.
3. Check for proper torque on all nuts and bolts before each use. Also check for excessive wear.
4. Check ball wear before each use. **(Note: Do not tow trailer with worn or damaged parts.)**

Curt Manufacturing Inc., warrants this product to be free of defects in material and/or workmanship at the time of retail purchase by the original purchaser. If the product is found to be defective, Curt Manufacturing Inc., may repair or replace the product, at their option, when the product is returned, prepaid, with proof of purchase. Alteration to, misuse of, or improper installation of this product voids the warranty. Curt Manufacturing Inc.'s liability is limited to repair or replacement of products found to be defective, and specifically excludes liability for incidental or consequential loss or damage.

\*\*\*DO NOT EXCEED VEHICLE MANUFACTURER'S RECOMMENDED TOWING CAPACITY.\*\*\*

# CAB TO TRAILER CLEARANCE

\*\*REMOVAL OF REAR WINDOW ACCESSORIES MAY BE REQUIRED.\*\*

## TRAILER

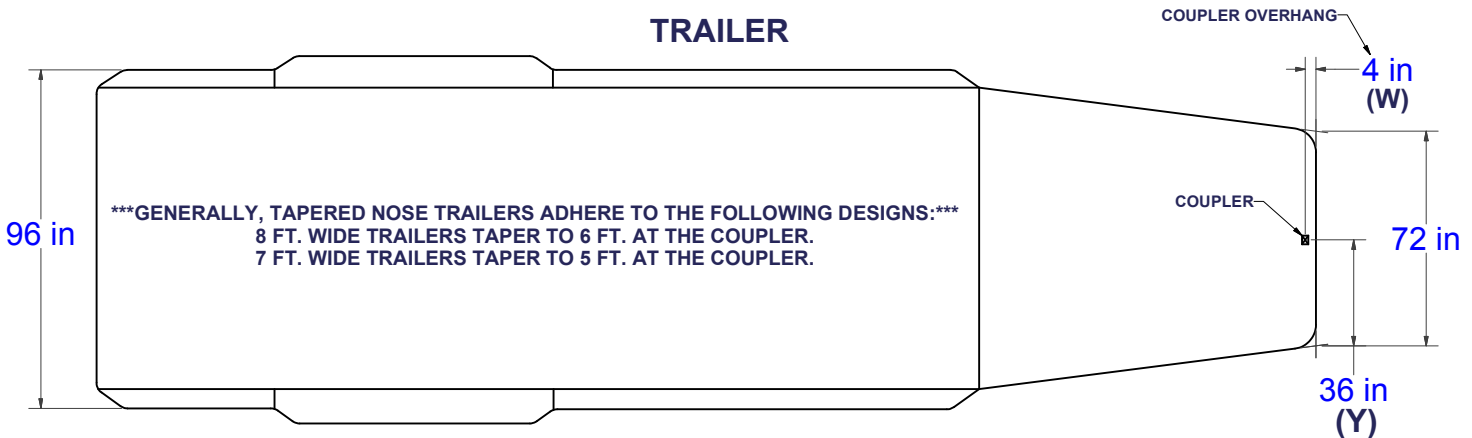

## LONG & SHORT TRUCK BEDS

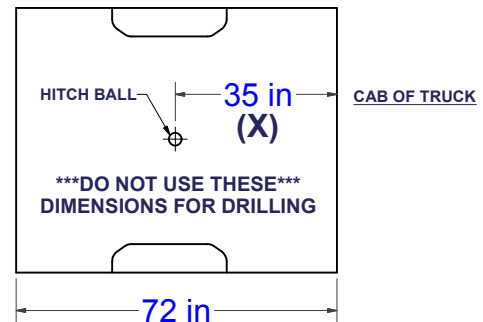
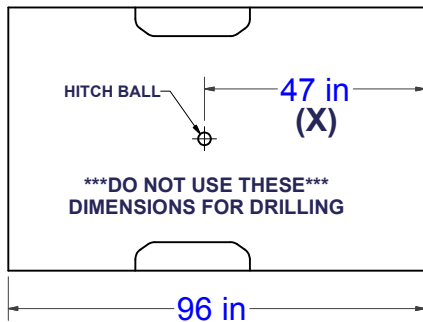

**\*\*WARNING REFERENCE CLEARANCE CALCULATOR BEFORE TOWING\*\***

### CLEARANCE CALCULATION

$$\begin{matrix} \text{(CAB TO BALL CENTER)} & - & 1/2 \text{ (TRAILER WIDTH)} & = & \text{(MINIMUM CLEARANCE)} \\ \text{(X)} & - & \text{(Y)} & = & \text{(Z)} \end{matrix}$$

IF THERE IS AN OVERHANG FROM THE COUPLER THEN THE EQUATION IS:

$$\begin{matrix} \text{[(X) - (W)]} & - & \text{(Y)} & = & \text{(Z)} \end{matrix}$$

\*\*\*IF (Z) IS POSITIVE, TRAILER **WILL NOT** INTERFERE WITH CAB OF TRUCK.\*\*\*  
 IF (Z) IS NEGATIVE, TRAILER **WILL** INTERFERE WITH CAB OF TRUCK!!!

#### EXAMPLE:

##### STANDARD TRAILER

$$X - Y = Z$$

$$35 - 36 = -1$$

(TRAILER **WILL INTERFERE** WITH CAB)

##### TRAILER WITH OVERHANG

$$\text{[(X) - (W)]} - Y = Z$$

$$[35 - 4] - 36 = -5$$

(TRAILER **WILL INTERFERE** WITH CAB)

#### YOUR CALCULATION:

(CAB TO BALL CENTER) \_\_\_\_\_

(COUPLER OVERHANG) - \_\_\_\_\_

1/2 (TRAILER WIDTH) - \_\_\_\_\_

(MINIMUM CLEARANCE) = \_\_\_\_\_

Curt Manufacturing Inc., warrants this product to be free of defects in material and/or workmanship at the time of retail purchase by the original purchaser. If the product is found to be defective, Curt Manufacturing Inc., may repair or replace the product, at their option, when the product is returned, prepaid, with proof of purchase. Alteration to, misuse of, or improper installation of this product voids the warranty. Curt Manufacturing Inc.'s liability is limited to repair or replacement of products found to be defective, and specifically excludes liability for incidental or consequential loss or damage.