



CURT[™]

The **FIRST** Name
in Towing Products[™]

DOUBLE LOCK GOOSENECK

INSTRUCTION MANUAL



Installer: Read and understand this manual. Fully instruct and demonstrate the operation of this gooseneck hitch to the end user. Include the importance of observing all warnings. Provide this manual in its entirety to the end-user.

60607

GOOSENECK HITCH

2/26/2013

Parts List			
ITEM	QTY	PART NUMBER	DESCRIPTION
1	2	CM-C60-CLA	SAFETY CHAIN LOOP ASSEMBLY
1.1	1	CM-C60-CL	2" x 3" SAFETY CHAIN LOOP
1.2	2	CM-C60-S	U-BOLT SPRING
1.3	2	1_2 - 13	NYLOCK HEX NUT
1.4	4	FW12SAE	FW, 1/2 SAE, ZP
2	2	3/8"	WASHER
3	3	#10-32 x 3/4	FLAT HEAD C'SUNK CAP SCREW
4	1	#10-24 NYLOCK HEX NUT	NYLOCK HEX NUT
5	1	#10-24 x 1.25 HHFS	HEX HEAD FLANGE SCREW
6	1	CM-C60-B	TURNOVER BALL COMPLETE
7	1	CM-C600-CLP	CAST LOCK PIN
8	1	CM-C60-R	.375" HANDLE ROD
9	1	CM-C60-CS	7.5 LB COMPRESSION SPRING
10	1	CM-C60-H	VINYL HANDLE GRIP
11	1	CM-C60-RC	RUBBER COVER
12	1	CM-UE1	.300" U-SHAPED EDGING
13	1	CM-C600-CR	3.75 DIA. x .375" CHROME RING

WARNING DO NOT invert ball when carrying heavy loads on 2 wheel drive trucks. The ball may hit the top of the differential, brake lines, or sensors.
(NOTE: Do not invert ball on any Toyota Tundra Models)

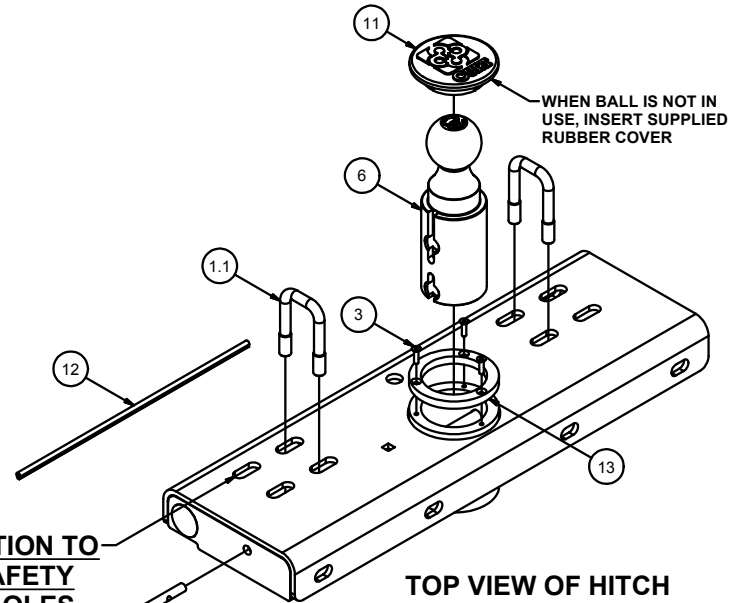

USE 60607 CENTER SECTION TO LOCATE AND DRILL SAFETY CHAIN ATTACHMENT HOLES

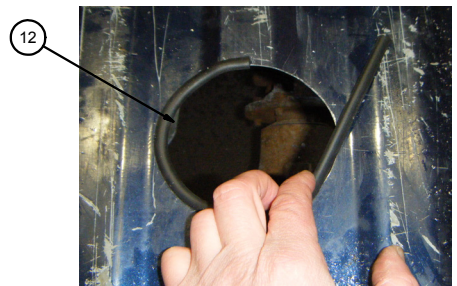
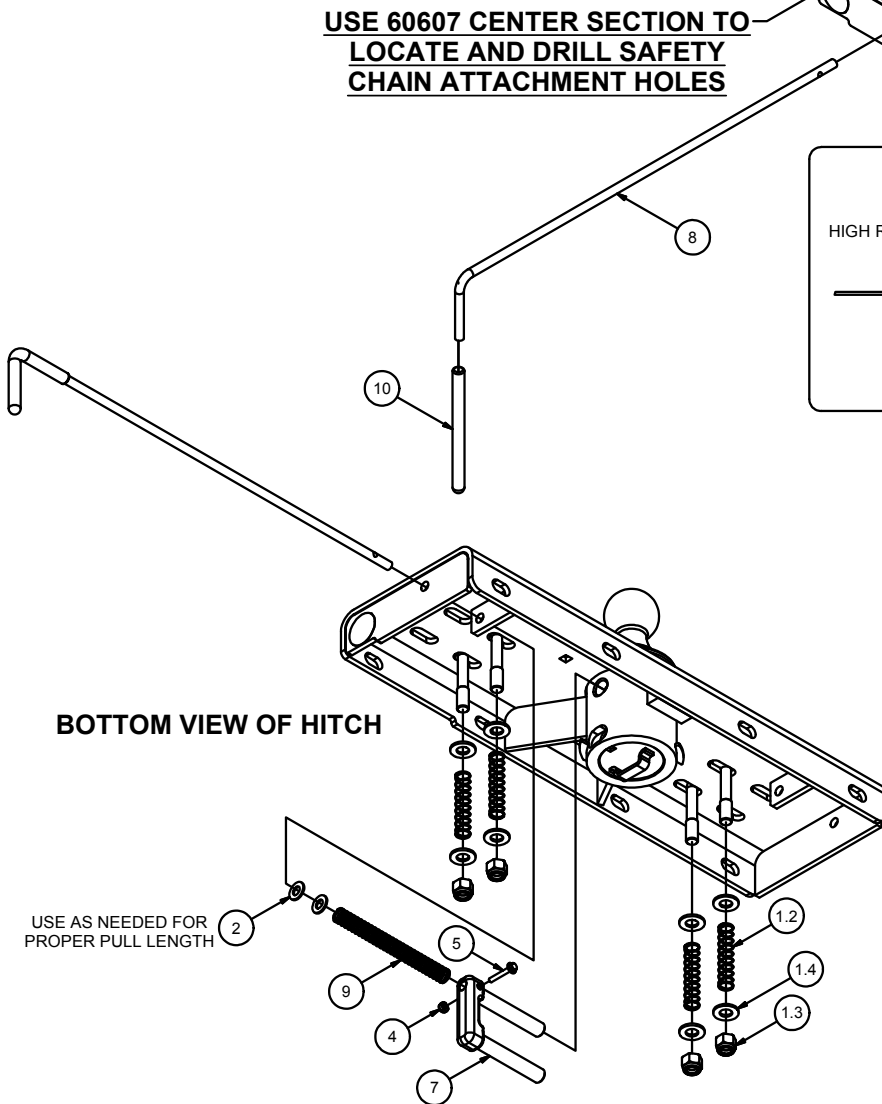
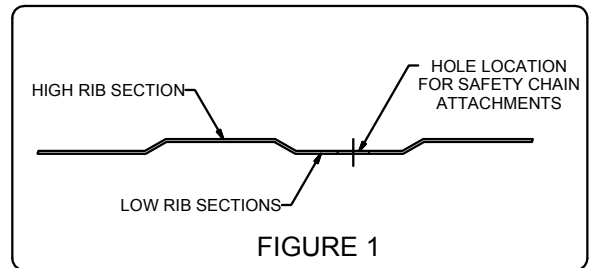

U-EDGING INSTALLED AROUND EDGE OF 4" HOLE IN TRUCK BED

Curt Manufacturing LLC., warrants this product to be free of defects in material and/or workmanship at the time of retail purchase by the original purchaser. If the product is found to be defective, Curt Manufacturing LLC., may repair or replace the product, at their option, when the product is returned, prepaid, with proof of purchase. Alteration to, misuse of, or improper installation of this product voids the warranty. Curt Manufacturing LLC.'s liability is limited to repair or replacement of products found to be defective, and specifically excludes liability for incidental or consequential loss or damage.

Warning!! Carefully examine the location of fuel lines, brake lines, and electrical wires BEFORE INSTALLATION. Brake, fuel, and electrical lines may need to be loosened or repositioned to provide clearance for new hardware. The installation of this hitch may require modification or removal of heat shields. The use of overload springs, air bags, etc. may be required when towing heavy loads.

Installing 60607 Turnover Gooseneck After Cross Arm Sub-kit Installation

- 1) Install rubber edging (CM-UE1) on cut edge for 60607 cylinder, trim excess.
- 2) Position the 60607 over the rear axle and up to the rear cross arm with the cylinder facing the correct direction for the application. Install four 1/2" x 1 3/4" carriage bolts into the 60607 first, then through the rear cross arm and secure with 1/2" flange nuts, finger tighten.
- 3) Move the front cross arm to the 60607 and install the 1/2" x 1 3/4" carriage bolts into the cross arm then through the 60607 and secure with 1/2" flange nuts.
- 4) Torque all 1/2" hardware to 110 ft-lbs.

Installing Safety Chain Attachments

- 1) From under the truck use the 60607 gooseneck as a template to drill four 1/2" holes for the safety chain attachments.
- 2) Using a 1/2" drill bit, drill the center of each slotted hole in the gooseneck. (**Note: Be sure the holes are drilled in the lower rib section of the truck bed as shown in FIGURE 1.**)
- 3) From inside the truck box place the two U-bolts (1.1) through the predrilled holes in the bed of the truck.
- 4) From beneath the truck place a washer (1.4), a spring (1.2), a washer (1.4) and a nylock nut (1.3) on each of the four U-bolt legs. Tighten the nylock nuts until flush with the bottom of the U-bolt.

Installing handle / lock

- 1) Insert Locking Pin (7) into the ball cylinder with handle rod hole located on top.
- 2) Slide rubber grip (10) onto handle rod.
- 3) Insert handle rod from outside vehicle, through the hole in the 60607 endplate, and through the rod guide as shown. (Handle rod may be installed on driver side or passenger side, depending on preference).
- 4) Slide the compression spring (9) over handle rod before inserting the handle rod into the locking pin. Insert handle rod into locking pin and secure with #10 screw (5) and nylock nut (4) as shown.
(**Note: Use 1-2 additional 3/8" washers (2) as needed to ensure proper pull length of locking pin.**)

Caution!!!

1. Check that all 1/2" hardware has been torqued to 110 ft-lbs.
2. Check that all side plate hardware has been torqued. Some hardware listed will not apply to your application.
 - 3/8" to 45 ft-lbs.
 - 1/2" to 110 ft-lbs.
 - 9/16" to 150 ft-lbs.
 - 5/8" to 210 ft-lbs.
 - 3/4" to 380 ft-lbs.
3. Re-attach Brake, Fuel, and Electrical lines so they do not contact any of the added fasteners.

60607 Operation

1. Pull the handle out as far as possible and rotate clockwise until the locking pin is disengaged and locked out.
2. Insert ball in the tow position into the cylinder by aligning the ball groove with the cylinder pin. If the groove and pin are not aligned simply rotate ball until the ball drops into place.
3. Rotate handle counter clockwise until locking pin snaps back into position. (Note: Be certain the locking pin passes completely through the ball and securely into the cylinder.)

60607 Installation check

1. Set ball in towing position and handle in locked position.
2. Connect the trailer to the hitch ball.
3. Check truck box clearance, there should be a minimum clearance of 6" between the bottom of the trailer overhang and the top of the box sides. Verify clearance between the truck and trailer at cab and box corners.

Maintenance (Required every 30 days or prior to use)

1. Keep hitch ball lubricated regularly. Use silicone spray or equivalent to prevent wear and rust.
2. Keep hitch assembly free of dirt and other foreign debris.
3. Check for proper torque on all nuts and bolts before each use. Also check for excessive wear.
4. Check for ball wear before each use. (**Note: Do not tow trailer with worn or damaged parts.**)

DO NOT EXCEED VEHICLE MANUFACTURER'S RECOMMENDED TOWING CAPACITY.

CAB TO TRAILER CLEARANCE

REMOVAL OF REAR WINDOW ACCESSORIES MAY BE REQUIRED.

TRAILER

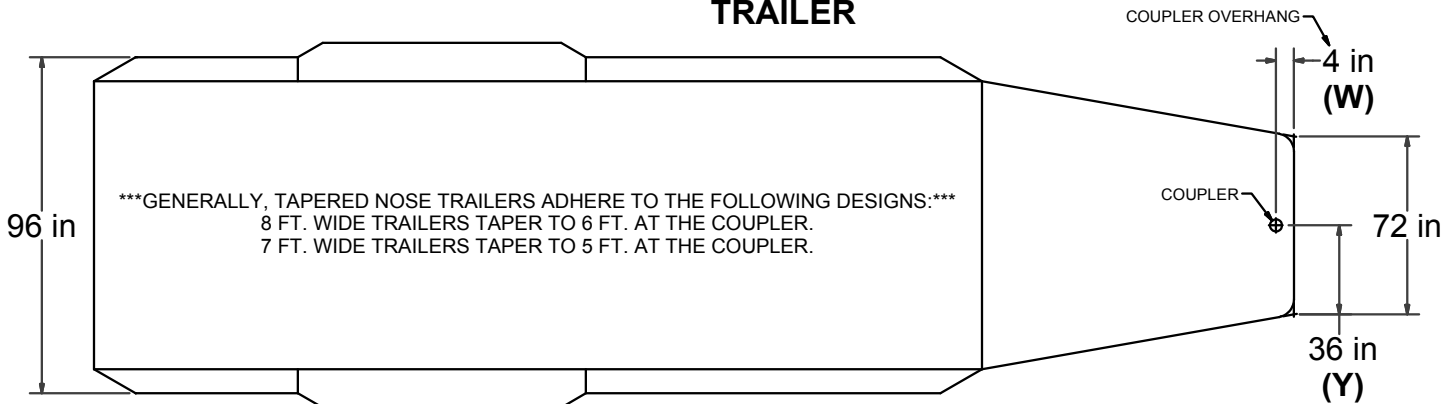

LONG & SHORT TRUCK BEDS

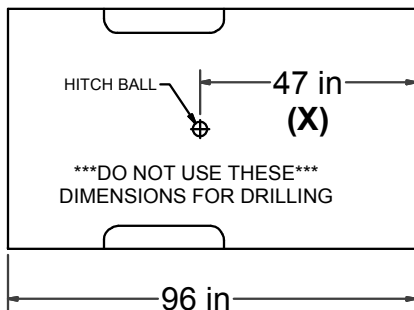

CAB OF TRUCK

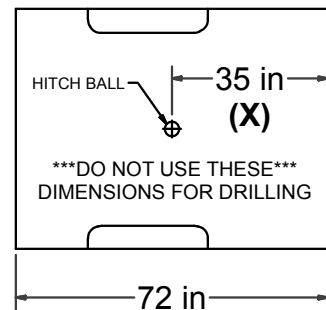

CAB OF TRUCK

WARNING REFERENCE CLEARANCE CALCULATOR BEFORE TOWING

CLEARANCE CALCULATION

$$\begin{matrix} \text{(CAB TO BALL CENTER)} & - & 1/2 \text{ (TRAILER WIDTH)} & = & \text{(MINIMUM CLEARANCE)} \\ \text{(X)} & - & \text{(Y)} & = & \text{(Z)} \end{matrix}$$

IF THERE IS AN OVERHANG FROM THE COUPLER THEN THE EQUATION IS:

$$[(X) - (W)] - (Y) = (Z)$$

IF (Z) IS POSITIVE, TRAILER **WILL NOT** INTERFERE WITH CAB OF TRUCK.
IF (Z) IS NEGATIVE, TRAILER **WILL** INTERFERE WITH CAB OF TRUCK!!!

EXAMPLE:

STANDARD TRAILER

$$\begin{aligned} X - Y &= Z \\ 35 - 36 &= -1 \\ \text{(TRAILER **WILL INTERFERE** WITH CAB)} \end{aligned}$$

TRAILER WITH OVERHANG

$$\begin{aligned} [(X) - (W)] - Y &= Z \\ [35 - 4] - 36 &= -5 \\ \text{(TRAILER **WILL INTERFERE** WITH CAB)} \end{aligned}$$

YOUR CALCULATION:

$$\begin{aligned} \text{(CAB TO BALL CENTER)} & \quad \underline{\hspace{2cm}} \\ - & \quad \underline{\hspace{2cm}} \\ \text{(COUPLER OVERHANG)} & \quad \underline{\hspace{2cm}} \\ - & \quad \underline{\hspace{2cm}} \\ 1/2 \text{ (TRAILER WIDTH)} & \quad \underline{\hspace{2cm}} \\ = & \quad \underline{\hspace{2cm}} \\ \text{(MINIMUM CLEARANCE)} & \quad \underline{\hspace{2cm}} \end{aligned}$$

Curt Manufacturing LLC., warrants this product to be free of defects in material and/or workmanship at the time of retail purchase by the original purchaser. If the product is found to be defective, Curt Manufacturing LLC., may repair or replace the product, at their option, when the product is returned, prepaid, with proof of purchase. Alteration to, misuse of, or improper installation of this product voids the warranty. Curt Manufacturing LLC.'s liability is limited to repair or replacement of products found to be defective, and specifically excludes liability for incidental or consequential loss or damage.

****DO NOT EXCEED RECOMMENDED VEHICLE TOWING WEIGHT!****

60661 SUBKIT

DODGE 2500 / 3500 SHORT AND LONG BED

9/27/2013

PAGE 1 OF 4

WARNING!! BRAKE, FUEL, AND ELECTRICAL LINES MAY NEED TO BE LOOSENED OR REPOSITIONED TO PROVIDE CLEARANCE FOR NEW HARDWARE. SOME MODELS MAY REQUIRE MODIFICATION OR REMOVAL OF HEAT SHIELDS. ON SHORT BED MODELS, CHECK FOR ADEQUATE TURNING CLEARANCE BETWEEN THE FRONT OF ALL TRAILERS AND THE TRUCK CAB. ON TWO WHEEL DRIVE TRUCKS A CLEARANCE CHECK MUST BE PERFORMED WHEN TRUCK IS LOADED AND UNLOADED TO VERIFY THE INVERTED BALL WILL NOT INTERFERE WITH THE TOP OF THE DIFFERENTIAL

Bolt Kit			
ITEM	QTY	PART NUMBER	DESCRIPTION
1	4	1/2-13 x 1, GR8	CARRIAGE BOLT
2	12	1/2-13 x 1 1/2, GR8	CARRIAGE BOLT
3	4	CM-SP3	.250 x 1.25 x 2.00" SQUARE HOLE SPACER
4	4	CM-SP12	.250 x 1.00 x 2.00" SQUARE HOLE SPACER
5	4	CM-1209-UBS	1/2-13 x 4 x 7.25 x 1 3/4 SQ U-BOLT
6	24	HFN 1213, GR8	HEX FLANGE NUT
7	4	M10 - 1.5 x 40mm	HEX BOLT
8	4	7/16"	CONICAL TOOTHED WASHER
9	4	M10 - 1.5 x 70 HEX	HEX BOLT

Parts List			
ITEM	QTY	PART NUMBER	DESCRIPTION
A	2	60661-CA	2.50 x 2.00 x .375" CROSS ARM
B	1	60661-DSWA	.250" DRIVER SIDE PLATE
C	1	60661-DSB	.250" DRIVER SIDE BRACKET
D	1	60661-PSWA	.250" PASSENGER SIDE PLATE
E	1	60661-PSB	.250" PASSENGER SIDE BRACKET
9	4	M10 - 1.5 x 70 HEX	HEX BOLT
F	2	60661-SP	.313" SPACER PLATE
G	1	CM-C655-EH	EXHAUST HANGER

- TOOLS REQUIRED**
- SAFETY GLASSES
 - RATCHET
 - 15mm, 17mm, & 3/4" SOCKETS
 - CRESCENT WRENCH
 - TORQUE WRENCH

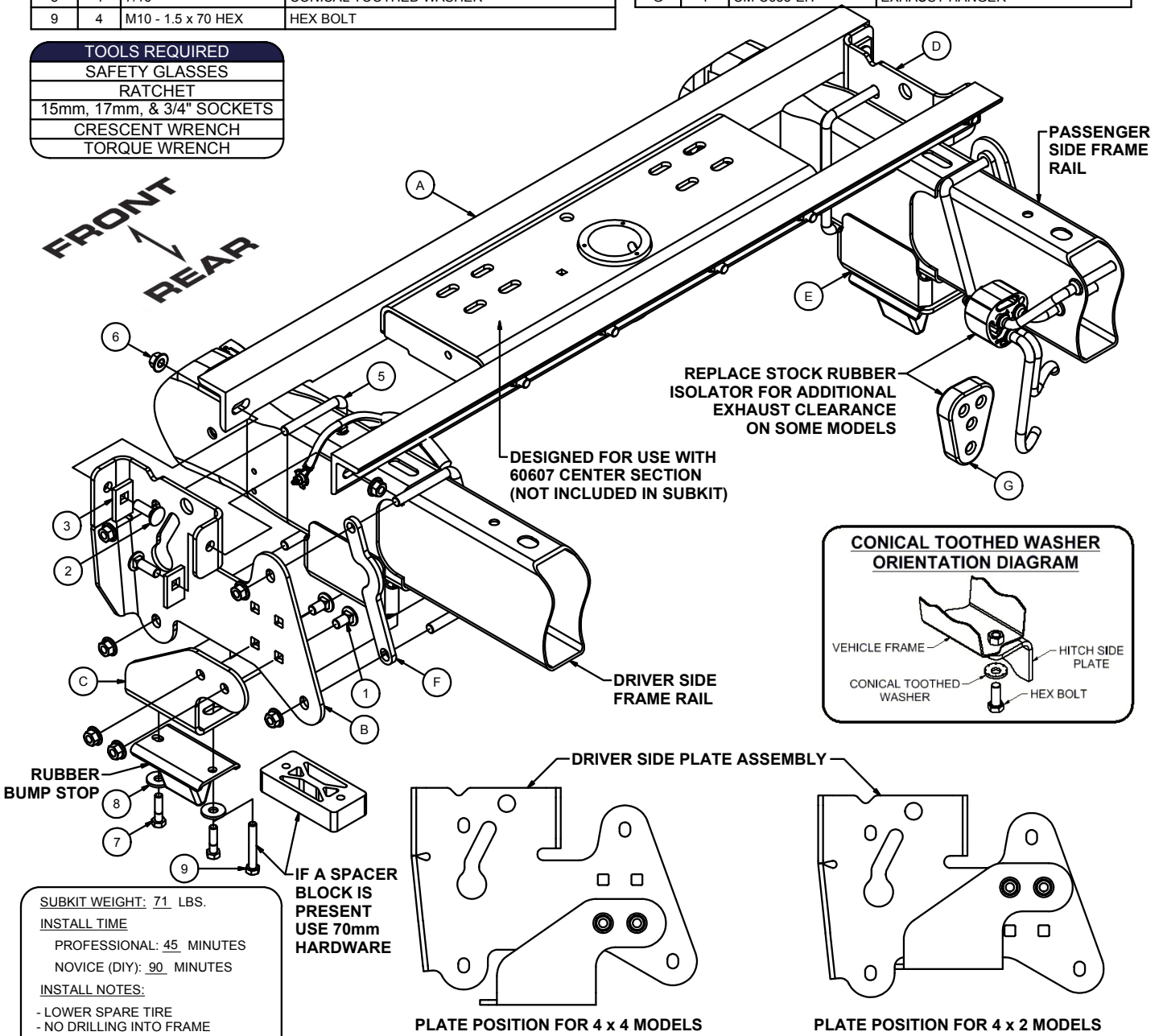

SUBKIT WEIGHT: 71 LBS.
 INSTALL TIME
 PROFESSIONAL: 45 MINUTES
 NOVICE (DIY): 90 MINUTES
 INSTALL NOTES:
 - LOWER SPARE TIRE
 - NO DRILLING INTO FRAME

PERIODICALLY CHECK THIS GOOSENECK HITCH TO ENSURE THAT ALL FASTENERS ARE TIGHT AND THAT ALL STRUCTURAL COMPONENTS ARE SOUND.

Curt Manufacturing Inc., warrants this product to be free of defects in material and/or workmanship at the time of retail purchase by the original purchaser. If the product is found to be defective, Curt Manufacturing Inc., may repair or replace the product, at their option, when the product is returned, prepaid, with proof of purchase. Alteration to, misuse of, or improper installation of this product voids the warranty. Curt Manufacturing Inc.'s liability is limited to repair or replacement of products found to be defective, and specifically excludes liability for incidental or consequential loss or damage.

****DO NOT EXCEED RECOMMENDED VEHICLE TOWING WEIGHT!****

60661 SUBKIT

DODGE 2500 / 3500 SHORT AND LONG BED

PAGE 2 OF 4

WARNING!! BRAKE, FUEL, AND ELECTRICAL LINES MAY NEED TO BE LOOSENED OR REPOSITIONED TO PROVIDE CLEARANCE FOR NEW HARDWARE. SOME MODELS MAY REQUIRE MODIFICATION OR REMOVAL OF HEAT SHIELDS. ON SHORT BED MODELS, CHECK FOR ADEQUATE TURNING CLEARANCE BETWEEN THE FRONT OF ALL TRAILERS AND THE TRUCK CAB. ON TWO WHEEL DRIVE TRUCKS A CLEARANCE CHECK MUST BE PERFORMED WHEN TRUCK IS LOADED AND UNLOADED TO VERIFY THE INVERTED BALL WILL NOT INTERFERE WITH THE TOP OF THE DIFFERENTIAL

INSTALLATION STEPS:

1. Mark the location for the hole in the truck bed. Measure from the tailgate end of the truck bed, by hooking a tape measure over the **rear of the truck box** and marking the correct location. (**NOTE: DO NOT MEASURE FROM EDGE OF THE TAILGATE**) Next, mark the center between the wheel wells. This marks the center point for the drill hole. This hole location is critical for the correct installation of this hitch. Measure, mark, and saw carefully. This location will put the ball approximately 3" in front of the axle.

Short Bed Installation = 42 1/2"

Long Bed Installation = 44 1/2"

NOTE: If the truck has a spray on bed liner, add approximately 1/8" when measuring the location of the center hole. If truck has a plastic bed liner, you may drill through both, but it is more difficult to accurately locate the midpoint between the wheel wells, and to keep the bed liner from moving while cutting the hole. Make a 4" hole at this location using a 4" hole saw.

2. Temporarily remove spare tire and temporarily remove plastic wheel well covers (if vehicle is equipped with them and if they are a style which prevents hitch installation).
3. Insert cross arm (A) by sliding it between the frame and the bottom of the truck bed. It needs to be inserted so the leg without the holes will be against the bottom of the bed and the leg with the holes will face the rear of the vehicle, see **FIGURE A**. **NOTE:** Use a crescent wrench to bend the metal flange below the bed outward to allow the cross arms to be slid into position. The cross arm can be used as a lever to add additional bend to the flange, if needed. Insert the cross arm in the location shown in **FIGURE A** until it spans the frame rails. Slide the cross arm forward so that it is next to the forward bed support.
4. Insert the second cross arm (A) in the same location that the first cross arm was inserted. Slide it in until it spans the frame rails. This needs to be inserted so the leg without the holes will be against the bottom of the bed and the leg with the holes will face the front of the vehicle, see **FIGURE A**.
5. Place the forward U-bolt (4) into position on the inside of the driver side frame rail. See **FIGURE B** for approximate location of the U-bolt. One or two of the wire harness clips may need to be unfastened from the inside of the driver side frame rail on some models for the U-bolt to be put into position. **NOTE: The U-bolts must be positioned under all the brake lines and wires, see FIGURE B.**
6. The rearmost rubber exhaust isolator may need to be replaced with the included isolator (G) on some models. Replace if needed for additional clearance between the exhaust and the hitch, see **PAGE 1**. This will only be needed on models with exhaust styles shown in **FIGURE C**.

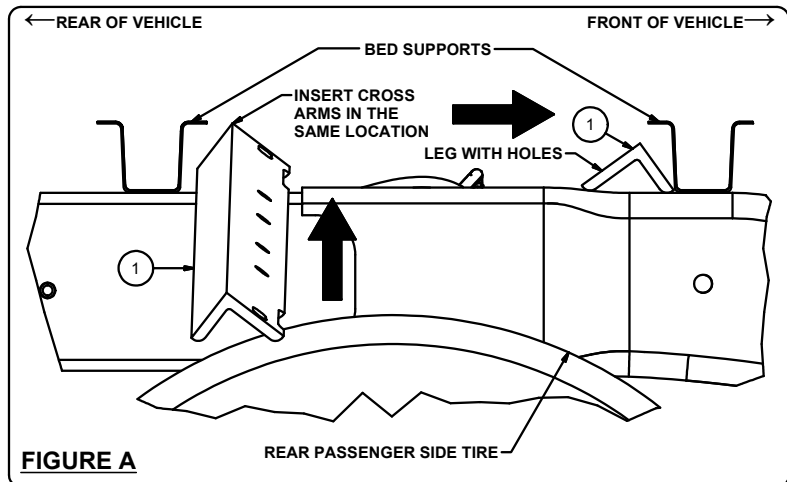

FIGURE A

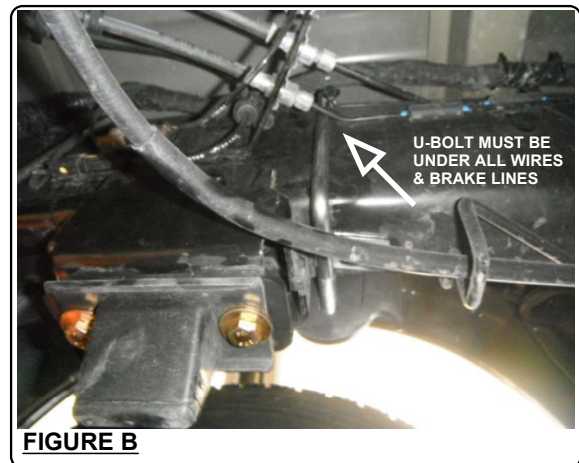

FIGURE B

PERIODICALLY CHECK THIS GOOSENECK HITCH TO ENSURE THAT ALL FASTENERS ARE TIGHT AND THAT ALL STRUCTURAL COMPONENTS ARE SOUND.

Curt Manufacturing Inc., warrants this product to be free of defects in material and/or workmanship at the time of retail purchase by the original purchaser. If the product is found to be defective, Curt Manufacturing Inc., may repair or replace the product, at their option, when the product is returned, prepaid, with proof of purchase. Alteration to, misuse of, or improper installation of this product voids the warranty. Curt Manufacturing Inc.'s liability is limited to repair or replacement of products found to be defective, and specifically excludes liability for incidental or consequential loss or damage.

****DO NOT EXCEED RECOMMENDED VEHICLE TOWING WEIGHT!****

60661 SUBKIT

DODGE 2500 / 3500 SHORT AND LONG BED

PAGE 3 OF 4

WARNING!! BRAKE, FUEL, AND ELECTRICAL LINES MAY NEED TO BE LOOSENED OR REPOSITIONED TO PROVIDE CLEARANCE FOR NEW HARDWARE. SOME MODELS MAY REQUIRE MODIFICATION OR REMOVAL OF HEAT SHIELDS. ON SHORT BED MODELS, CHECK FOR ADEQUATE TURNING CLEARANCE BETWEEN THE FRONT OF ALL TRAILERS AND THE TRUCK CAB. ON TWO WHEEL DRIVE TRUCKS A CLEARANCE CHECK MUST BE PERFORMED WHEN TRUCK IS LOADED AND UNLOADED TO VERIFY THE INVERTED BALL WILL NOT INTERFERE WITH THE TOP OF THE DIFFERENTIAL

INSTALLATION STEPS CONTINUED:

7. Raise the center section into position. **NOTE:** The gooseneck center cylinder will be offset towards the rear of the vehicle, see **PAGE 1**. Loosely attach to the forward cross arm by placing four 1/2" x 1 1/2" carriage bolts (2) with four CM-SP12 spacers (4) in through the forward cross arm and attach center section with four 1/2" hex flange nuts (6), see **FIGURE D**. Slide the rearward cross arm forward and loosely attach to the center section by inserting four 1/2" x 1 1/2" carriage bolts (2) in through the center and out the rearward cross arm. Attach with four 1/2" hex flange nuts (6), see **FIGURE D**.



FIGURE C

8. Loosely assemble the side plates with brackets (B & C) and (D & E) using 1/2" x 1" carriage bolts (1) and 1/2" hex flange nuts (6). The brackets will attach to the top set of holes on the side plates for two wheel drive models and the bottom set of holes for four wheel drive models, see **PAGE 1**.

9. Remove the the rubber bump stop from underneath each frame rail by removing two M10 bolts from each. Save the rubber bump stops for reinstallation but the hardware removed will not be reinstalled.

10. Place driver side plate assembly over the U-bolt (5) which was positioned in step 5. Attach to the U-bolt with two 1/2" hex flange nuts (6). **NOTE:** The ground wire on the outside of the driver side frame rail on 2012 and earlier models must not be pinched between the driver side plate (B) and frame. This ground wire may need to be loosened, rotated slightly and retightened for the plate to be put into position.

11. Insert the rearward U-bolt (5) over the inside of the driver side frame rail and position the spacer (F) between the plate and frame rail in the orientation shown on **PAGE 1**.

Loosely attach to the driver side plate assembly using two 1/2" hex flange nuts (6). One of the wire harness clips may need to be unfastened from the inside of the driver side frame rail on some models for the U-bolt to be positioned.

12. Clamp the driver side plate assembly between the rubber bump stop and frame rail using the supplied 7/16" conical toothed washers (7) and M10 - 1.5 x 40mm hex bolts (6). Use the M10 x 70mm bolts (9) if spacer block is present (the spacer block will be clamped between the driver side plate assembly and the rubber bump stop).

13. Attach driver side plate assembly to the cross arms by inserting 1/2" x 1 1/2" carriage bolts (2) with CM-SP3 spacers (3) in through the driver side plate (B) and out the cross arms (A). Attach with 1/2" hex flange nuts (6), see **PAGE 1**.

14. Insert the forward U-bolt (5) into position on the inside of the passenger side frame rail and loosely attach the passenger side plate assembly using two 1/2" hex flange nuts (6). Repeat steps 11 -13 on the passenger side with this plate assembly.

15. Torque all fasteners in the following order: **First:** Torque the center section to the front and rear cross arms. **Second:** Torque the side plates to the truck frame and U-bolts on both sides. **Third:** Torque the side plates to the front and rear cross arms. Torque all 1/2" fasteners to 110 ft-lbs, and M10 hardware to 45 ft-lbs.

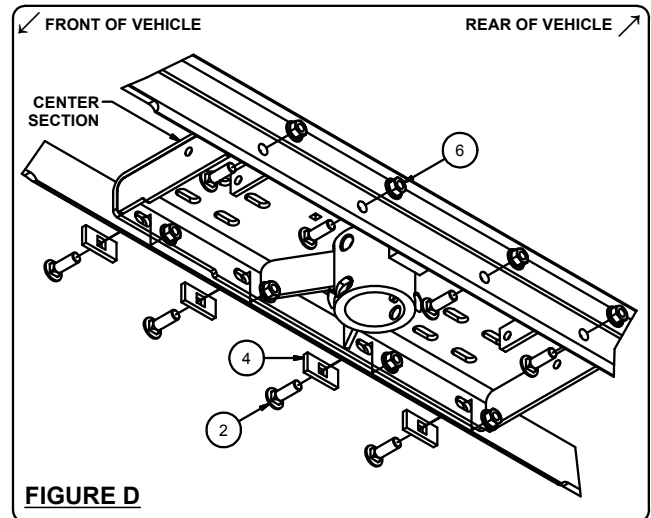

FIGURE D

(REFER TO GOOSENECK HITCH INSTRUCTIONS FOR INSTALLATION COMPLETION AND OPERATING PROCEDURES)

PERIODICALLY CHECK THIS GOOSENECK HITCH TO ENSURE THAT ALL FASTENERS ARE TIGHT AND THAT ALL STRUCTURAL COMPONENTS ARE SOUND.

Curt Manufacturing Inc., warrants this product to be free of defects in material and/or workmanship at the time of retail purchase by the original purchaser. If the product is found to be defective, Curt Manufacturing Inc., may repair or replace the product, at their option, when the product is returned, prepaid, with proof of purchase. Alteration to, misuse of, or improper installation of this product voids the warranty. Curt Manufacturing Inc.'s liability is limited to repair or replacement of products found to be defective, and specifically excludes liability for incidental or consequential loss or damage.

CAB TO TRAILER CLEARANCE

REMOVAL OF REAR WINDOW ACCESSORIES MAY BE REQUIRED.

TRAILER

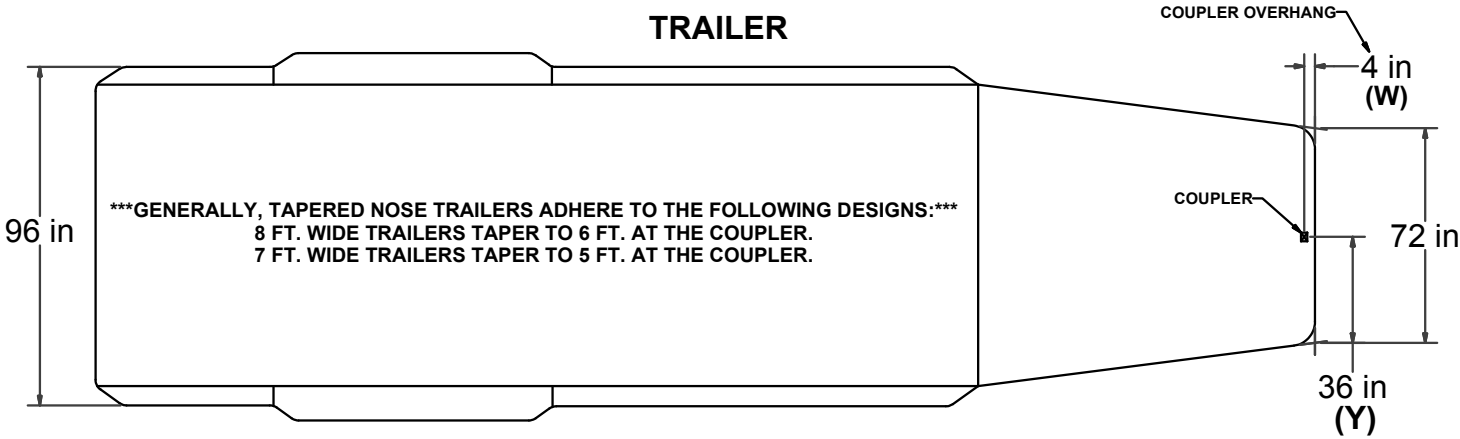

LONG & SHORT TRUCK BEDS

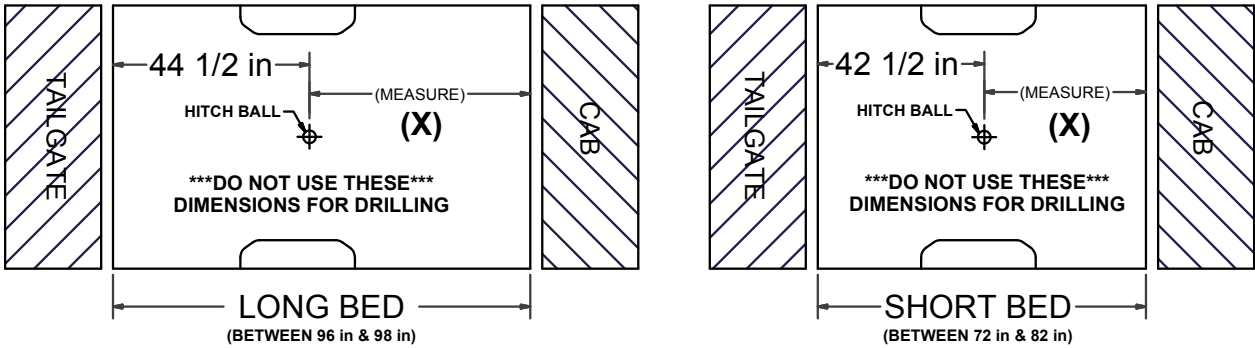

CLEARANCE CALCULATION

$$(CAB TO BALL CENTER) - \frac{1}{2} (TRAILER WIDTH) = (MINIMUM CLEARANCE)$$

$$(X) - (Y) = (Z)$$

IF THERE IS AN OVERHANG FROM THE COUPLER THEN THE EQUATION IS:

$$[(X) - (W)] - (Y) = (Z)$$

IF (Z) IS POSITIVE, TRAILER **WILL NOT** INTERFERE WITH CAB OF TRUCK.
 IF (Z) IS NEGATIVE, TRAILER **WILL** INTERFERE WITH CAB OF TRUCK!!!

EXAMPLE:

STANDARD TRAILER
 $X - Y = Z$
 $35 - 36 = -1$
 (TRAILER **WILL INTERFERE** WITH CAB)

TRAILER WITH OVERHANG
 $[(X) - (W)] - Y = Z$
 $[35 - 4] - 36 = -5$
 (TRAILER **WILL INTERFERE** WITH CAB)

YOUR CALCULATION:

(CAB TO BALL CENTER) _____

(COUPLER OVERHANG) _____

$\frac{1}{2}$ (TRAILER WIDTH) _____

(MINIMUM CLEARANCE) _____

Curt Manufacturing Inc., warrants this product to be free of defects in material and/or workmanship at the time of retail purchase by the original purchaser. If the product is found to be defective, Curt Manufacturing Inc., may repair or replace the product, at their option, when the product is returned, prepaid, with proof of purchase. Alteration to, misuse of, or improper installation of this product voids the warranty. Curt Manufacturing Inc.'s liability is limited to repair or replacement of products found to be defective, and specifically excludes liability for incidental or consequential loss or damage.