



CURTTM

The **FIRST** Name
in Towing ProductsTM

DOUBLE LOCK GOOSENECK

INSTRUCTION MANUAL



Installer: Read and understand this manual. Fully instruct and demonstrate the operation of this gooseneck hitch to the end user. Include the importance of observing all warnings. Provide this manual in its entirety to the end-user.

60607

GOOSENECK HITCH

2/26/2013

Parts List			
ITEM	QTY	PART NUMBER	DESCRIPTION
1	2	CM-C60-CLA	SAFETY CHAIN LOOP ASSEMBLY
1.1	1	CM-C60-CL	2" x 3" SAFETY CHAIN LOOP
1.2	2	CM-C60-S	U-BOLT SPRING
1.3	2	1_2 - 13	NYLOCK HEX NUT
1.4	4	FW12SAE	FW, 1/2 SAE, ZP
2	2	3/8"	WASHER
3	3	#10-32 x 3/4	FLAT HEAD C'SUNK CAP SCREW
4	1	#10-24 NYLOCK HEX NUT	NYLOCK HEX NUT
5	1	#10-24 x 1.25 HHFS	HEX HEAD FLANGE SCREW
6	1	CM-C60-B	TURNOVER BALL COMPLETE
7	1	CM-C600-CLP	CAST LOCK PIN
8	1	CM-C60-R	.375" HANDLE ROD
9	1	CM-C60-CS	7.5 LB COMPRESSION SPRING
10	1	CM-C60-H	VINYL HANDLE GRIP
11	1	CM-C60-RC	RUBBER COVER
12	1	CM-UE1	.300" U-SHAPED EDGING
13	1	CM-C600-CR	3.75 DIA. x .375" CHROME RING

WARNING DO NOT invert ball when carrying heavy loads on 2 wheel drive trucks. The ball may hit the top of the differential, brake lines, or sensors.
(NOTE: Do not invert ball on any Toyota Tundra Models)

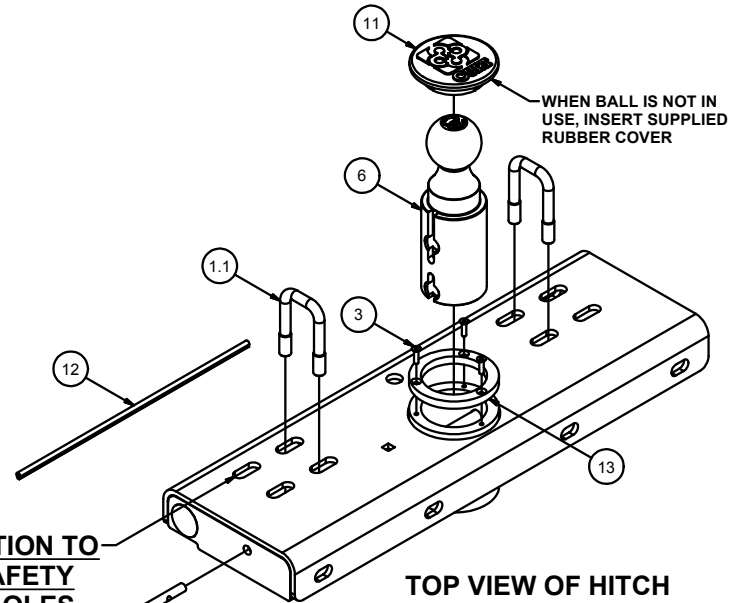

USE 60607 CENTER SECTION TO LOCATE AND DRILL SAFETY CHAIN ATTACHMENT HOLES

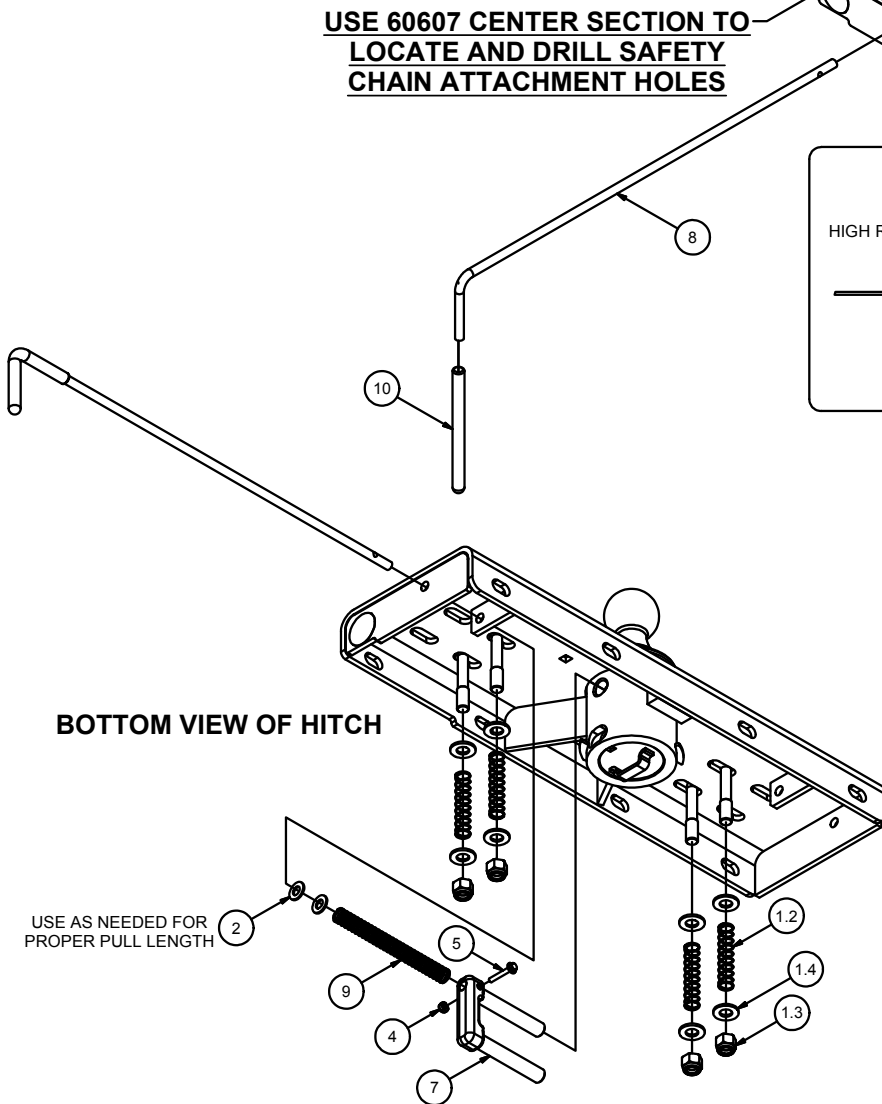
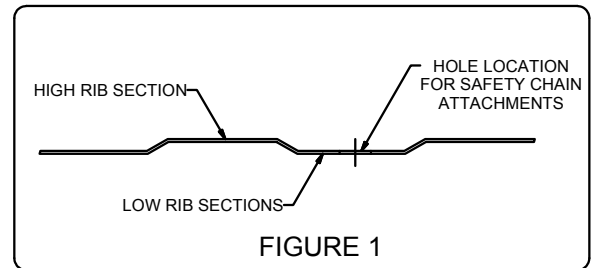

U-EDGING INSTALLED AROUND EDGE OF 4" HOLE IN TRUCK BED

Curt Manufacturing LLC., warrants this product to be free of defects in material and/or workmanship at the time of retail purchase by the original purchaser. If the product is found to be defective, Curt Manufacturing LLC., may repair or replace the product, at their option, when the product is returned, prepaid, with proof of purchase. Alteration to, misuse of, or improper installation of this product voids the warranty. Curt Manufacturing LLC.'s liability is limited to repair or replacement of products found to be defective, and specifically excludes liability for incidental or consequential loss or damage.

Warning!! Carefully examine the location of fuel lines, brake lines, and electrical wires BEFORE INSTALLATION. Brake, fuel, and electrical lines may need to be loosened or repositioned to provide clearance for new hardware. The installation of this hitch may require modification or removal of heat shields. The use of overload springs, air bags, etc. may be required when towing heavy loads.

Installing 60607 Turnover Gooseneck After Cross Arm Sub-kit Installation

- 1) Install rubber edging (CM-UE1) on cut edge for 60607 cylinder, trim excess.
- 2) Position the 60607 over the rear axle and up to the rear cross arm with the cylinder facing the correct direction for the application. Install four 1/2" x 1 3/4" carriage bolts into the 60607 first, then through the rear cross arm and secure with 1/2" flange nuts, finger tighten.
- 3) Move the front cross arm to the 60607 and install the 1/2" x 1 3/4" carriage bolts into the cross arm then through the 60607 and secure with 1/2" flange nuts.
- 4) Torque all 1/2" hardware to 110 ft-lbs.

Installing Safety Chain Attachments

- 1) From under the truck use the 60607 gooseneck as a template to drill four 1/2" holes for the safety chain attachments.
- 2) Using a 1/2" drill bit, drill the center of each slotted hole in the gooseneck. (**Note: Be sure the holes are drilled in the lower rib section of the truck bed as shown in FIGURE 1.**)
- 3) From inside the truck box place the two U-bolts (1.1) through the predrilled holes in the bed of the truck.
- 4) From beneath the truck place a washer (1.4), a spring (1.2), a washer (1.4) and a nylock nut (1.3) on each of the four U-bolt legs. Tighten the nylock nuts until flush with the bottom of the U-bolt.

Installing handle / lock

- 1) Insert Locking Pin (7) into the ball cylinder with handle rod hole located on top.
- 2) Slide rubber grip (10) onto handle rod.
- 3) Insert handle rod from outside vehicle, through the hole in the 60607 endplate, and through the rod guide as shown. (Handle rod may be installed on driver side or passenger side, depending on preference).
- 4) Slide the compression spring (9) over handle rod before inserting the handle rod into the locking pin. Insert handle rod into locking pin and secure with #10 screw (5) and nylock nut (4) as shown.
(**Note: Use 1-2 additional 3/8" washers (2) as needed to ensure proper pull length of locking pin.**)

Caution!!!

1. Check that all 1/2" hardware has been torqued to 110 ft-lbs.
2. Check that all side plate hardware has been torqued. Some hardware listed will not apply to your application.
 - 3/8" to 45 ft-lbs.
 - 1/2" to 110 ft-lbs.
 - 9/16" to 150 ft-lbs.
 - 5/8" to 210 ft-lbs.
 - 3/4" to 380 ft-lbs.
3. Re-attach Brake, Fuel, and Electrical lines so they do not contact any of the added fasteners.

60607 Operation

1. Pull the handle out as far as possible and rotate clockwise until the locking pin is disengaged and locked out.
2. Insert ball in the tow position into the cylinder by aligning the ball groove with the cylinder pin. If the groove and pin are not aligned simply rotate ball until the ball drops into place.
3. Rotate handle counter clockwise until locking pin snaps back into position. (Note: Be certain the locking pin passes completely through the ball and securely into the cylinder.)

60607 Installation check

1. Set ball in towing position and handle in locked position.
2. Connect the trailer to the hitch ball.
3. Check truck box clearance, there should be a minimum clearance of 6" between the bottom of the trailer overhang and the top of the box sides. Verify clearance between the truck and trailer at cab and box corners.

Maintenance (Required every 30 days or prior to use)

1. Keep hitch ball lubricated regularly. Use silicone spray or equivalent to prevent wear and rust.
2. Keep hitch assembly free of dirt and other foreign debris.
3. Check for proper torque on all nuts and bolts before each use. Also check for excessive wear.
4. Check for ball wear before each use. (**Note: Do not tow trailer with worn or damaged parts.**)

DO NOT EXCEED VEHICLE MANUFACTURER'S RECOMMENDED TOWING CAPACITY.

CAB TO TRAILER CLEARANCE

REMOVAL OF REAR WINDOW ACCESSORIES MAY BE REQUIRED.

TRAILER

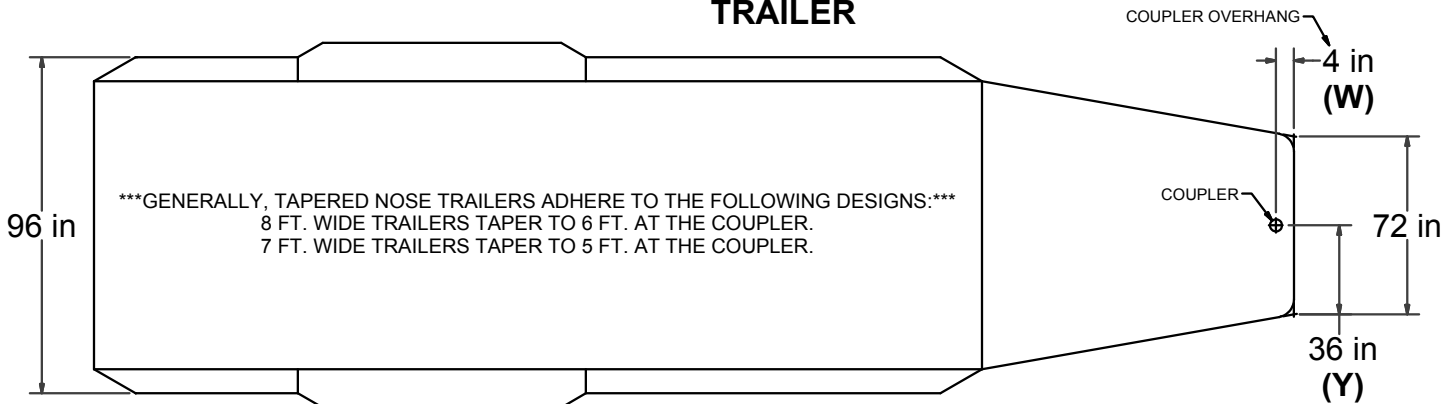

LONG & SHORT TRUCK BEDS

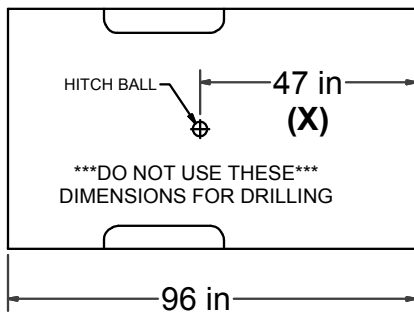

CAB OF TRUCK

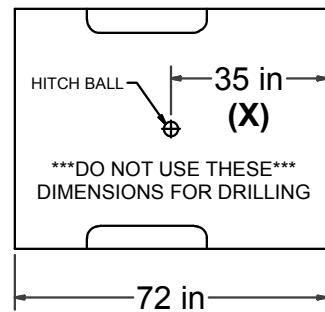

CAB OF TRUCK

WARNING REFERENCE CLEARANCE CALCULATOR BEFORE TOWING

CLEARANCE CALCULATION

$$\begin{matrix} \text{(CAB TO BALL CENTER)} & - & 1/2 \text{ (TRAILER WIDTH)} & = & \text{(MINIMUM CLEARANCE)} \\ \text{(X)} & - & \text{(Y)} & = & \text{(Z)} \end{matrix}$$

IF THERE IS AN OVERHANG FROM THE COUPLER THEN THE EQUATION IS:

$$[(X) - (W)] - (Y) = (Z)$$

IF (Z) IS POSITIVE, TRAILER **WILL NOT** INTERFERE WITH CAB OF TRUCK.
IF (Z) IS NEGATIVE, TRAILER **WILL** INTERFERE WITH CAB OF TRUCK!!!

EXAMPLE:

STANDARD TRAILER

$$X - Y = Z$$

$$35 - 36 = -1$$

(TRAILER **WILL INTERFERE** WITH CAB)

TRAILER WITH OVERHANG

$$[(X) - (W)] - Y = Z$$

$$[35 - 4] - 36 = -5$$

(TRAILER **WILL INTERFERE** WITH CAB)

YOUR CALCULATION:

(CAB TO BALL CENTER) _____

- _____

(COUPLER OVERHANG) _____

- _____

1/2 (TRAILER WIDTH) _____

= _____

(MINIMUM CLEARANCE) _____

Curt Manufacturing LLC., warrants this product to be free of defects in material and/or workmanship at the time of retail purchase by the original purchaser. If the product is found to be defective, Curt Manufacturing LLC., may repair or replace the product, at their option, when the product is returned, prepaid, with proof of purchase. Alteration to, misuse of, or improper installation of this product voids the warranty. Curt Manufacturing LLC.'s liability is limited to repair or replacement of products found to be defective, and specifically excludes liability for incidental or consequential loss or damage.

60635**94-01 DODGE 1/2 TON TRUCKS
94-02 DODGE 3/4 & 1 TON TRUCKS**

WARNING!! BRAKE, FUEL, AND ELECTRICAL LINES MAY NEED TO BE LOOSENED OR REPOSITIONED TO PROVIDE CLEARANCE FOR NEW HARDWARE. ALL MODELS REQUIRE MODIFICATION OR REMOVAL OF HEAT SHIELDS. ON SHORT BED MODELS, CHECK FOR ADEQUATE TURNING CLEARANCE BETWEEN THE FRONT OF ALL TRAILERS AND THE TRUCK CAB.

WARNING!! ON TWO WHEEL DRIVE TRUCKS A CLEARANCE CHECK MUST BE PERFORMED WHEN TRUCK IS LOADED AND UNLOADED TO VERIFY THE INVERTED BALL WILL NOT INTERFERE WITH THE TOP OF THE DIFFERENTIAL

INSTALLATION STEPS**BEFORE INSTALLING**

An overhead lifting device, such as chain falls, engine hoist, or cable come-a-long, can be used to lift the center section of the hitch in place. Lower a loop of rope or chain through the hole in the truck bed floor and attach it to the round hitch receiver tube in the center section. Use the lifting device to raise the center section until the round hitch receiver tube that protrudes from the center section fits in the hole in the truck bed floor. Maintaining upward pressure may facilitate fastening the cross-member to the center section, especially if the truck bed floor has been distorted downward from heavy use. If you use an overhead-lifting device, it should be disconnected before squaring the center section across the frame, installing the sideplates and torquing fasteners.

- 1) Lower and remove spare tire.
- 2) On four wheel drive applications, remove plastic wheel well inserts(both sides).
- 3) Mark the location for the hole in the truck bed. Measure from the tail gate end of the truck bed, by hooking a tape measure over the **back of the truck box** and marking the correct location.(NOTE: DO NOT MEASURE FROM EDGE OF TAILGATE) Next, mark the center between the wheel wells. This marks the center point for the drill hole. This hole location is critical for the correct installation of this hitch. Measure, mark, and saw carefully. This location will put the ball 4"-5" in front of the axle.

Short Bed Installation	44 3/8"
Long Bed Installation	48 3/8"

NOTE: If truck has a plastic bed liner, you may drill through both, but it is more difficult to accurately locate the midpoint between the wheel wells, and to keep the bed liner from moving while cutting the hole. Make a 4"(3 5/8" for C-630/C-640) hole at this location using a 4"(or 3 5/8") hole saw, or by making a 4"(or 3 5/8") circle and cutting it out with a saber saw equipped with a metal cutting blade.

- 4) Install the rear cross arm by sliding it between the truck bed and truck frame on the passenger side. Swing the driver's side into place as shown in **FIGURE 1**, then push the cross arm towards the back of truck.
(NOTE: HOLES IN THE CROSS ARM MUST BE FACING THE FRONT END OF THE TRUCK)

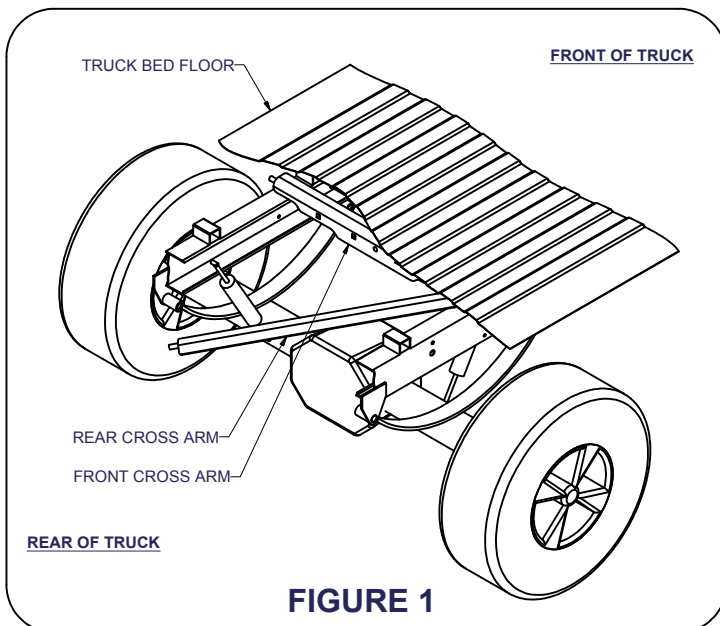
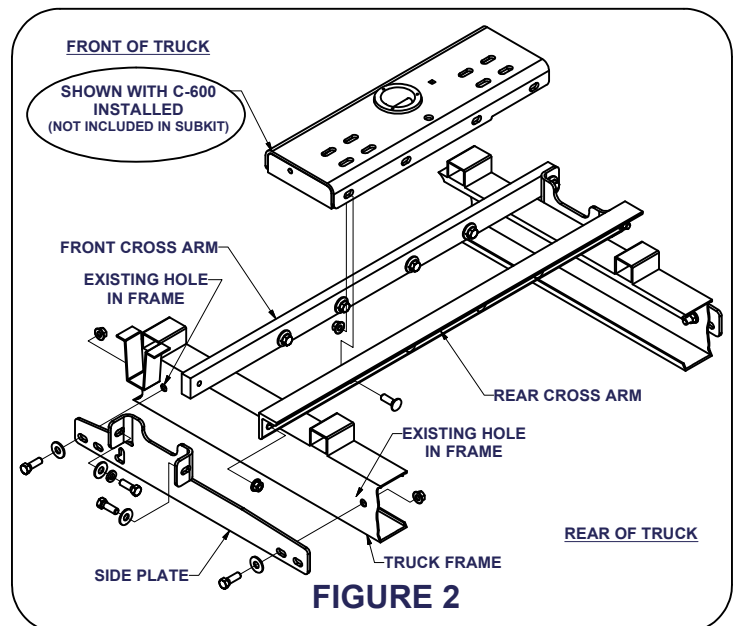
**FIGURE 1****FIGURE 2**

Curt Manufacturing Inc., warrants this product to be free of defects in material or workmanship at the time of retail purchase by the original purchaser. If the product is found to be defective, Curt Manufacturing Inc., may repair or replace the product, at their option, when the product is returned, prepaid, with proof of purchase. Alteration to, misuse of, or improper installation of this product voids the warrant. Curt Manufacturing Inc.'s liability is limited to repair or replacement of products found to be defective, and specifically excludes liability for incidental or consequential loss or damage.

****DO NOT EXCEED RECOMMENDED VEHICLE TOWING WEIGHT!****

60635

**94-01 DODGE 1/2 TON TRUCKS
94-02 DODGE 3/4 & 1 TON TRUCKS**

WARNING!! BRAKE, FUEL, AND ELECTRICAL LINES MAY NEED TO BE LOOSENED OR REPOSITIONED TO PROVIDE CLEARANCE FOR NEW HARDWARE. ALL MODELS REQUIRE MODIFICATION OR REMOVAL OF HEAT SHIELDS. ON SHORT BED MODELS, CHECK FOR ADEQUATE TURNING CLEARANCE BETWEEN THE FRONT OF ALL TRAILERS AND THE TRUCK CAB.

Installation Steps Continued

- 5) Install the front cross arm by sliding it between the truck frame and truck bed above one of the rear tires. Slide through until both sides are resting on the truck frame. It may be necessary to install the same as the rear cross arm as stated in step 4.
- 6) Raise the center section in position between the cross arms **with the ball cylinder towards the front of truck**. The round hitch receiver that protrudes from the top of the center section must fit through the hole in the truck bed. Using (4) 1/2" bolts, washers, and lock washers, attach the center section to the threaded holes in the front cross arm. Next, attach the rear cross arm (angle iron) to the center section using (4) 1/2" carriage bolts and flange nuts. **(Finger tight only.)**
- 7) For extended cab short bed applications, it may be necessary to remove the metal tabs from the bed supports, prior to installing the sideplates. The tabs are located on the truck bed cross-member in the front part of the wheel opening. Before removing, attempt to pry the tabs (if needed) away from the truck frame enough to fit the 1/4" sideplate behind them.
- 8) Square the center section and cross arms across the frame. Thread a 1 1/2" bolt with a flat and lock washer through the front flange of the sideplate into the front cross arm. Place a 1 1/2" bolt with a flat washer through the back flange of the sideplate into the rear cross arm. (As shown in **Figure 2**) **Finger tight** with a 1/2" flange nut. **(REPEAT FOR OTHER SIDE)**
- 9) Align one front hole and one rear hole of each sideplate to the existing holes in the truck frame, and using a 1 1/2" bolt with a 1/2" flat washer attach the sideplates to the truck frame. (As shown in **Figure 2**) **Finger tight** with a 1/2" flange nut.
- 10) With the sideplates installed on both sides, torque all fasteners to 110 ft.-lbs. in the following order:
First: Torque the center section to the front and rear cross arms.
Second: Torque the sideplates to the truck frame on both sides.
Third: Torque the sideplate flanges to the front and rear cross arms.
- 11) To install handle rod, line it up on the driver side to get its position and then proceed to cut the bed flange rail up 3/4" and 5" wide. Then, a 6" wide by 5" high hole, lined up with the bed flange cut-out, must be cut into the plastic wheel well in order to get a hand through to use the handle rod.

Parts List			
ITEM	QTY	PART NUMBER	DESCRIPTION
1	10	HFN 1213	HEX FLANGE NUT
2	12	1/2 - 13 x 1 1/2	HEX BOLT
3	12	FW12	FW, 12, ZP
4	4	1/2-13 x 1 1/2	CARRIAGE BOLT
5	6	1/2"	LOCK WASHER

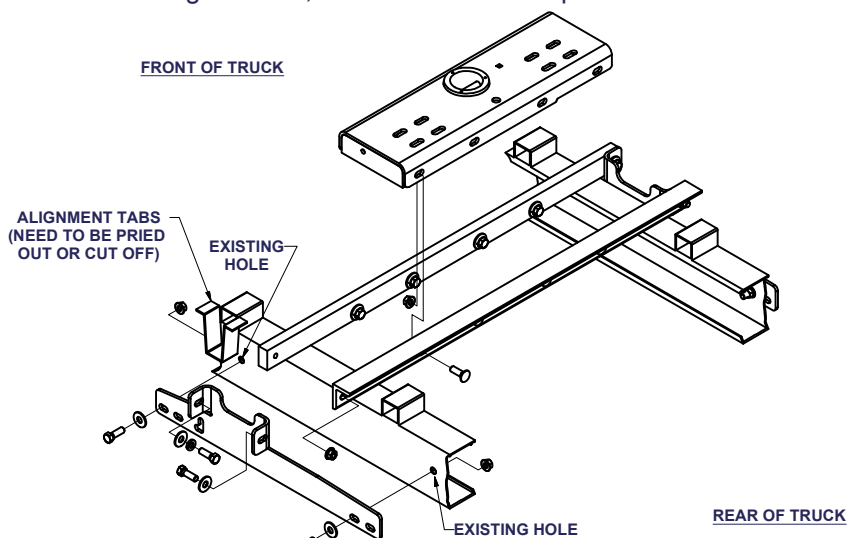

(REFER TO GOOSENECK HITCH INSTRUCTIONS FOR INSTALLATION AND OPERATING PROCEDURES)

Maintenance (Required every 30 days or prior to use)

1. Keep hitch ball lubricated regularly. Use silicone spray or equivalent to prevent wear and rust.
2. Keep hitch assembly free of dirt and other foreign debris.
3. Check for proper torque on all nuts and bolts before each use. Also check for excessive wear.
4. Check for ball wear before each use. **(Note: Do not tow trailer with worn or damaged parts.)**

Curt Manufacturing Inc., warrants this product to be free of defects in material or workmanship at the time of retail purchase by the original purchaser. If the product is found to be defective, Curt Manufacturing Inc., may repair or replace the product, at their option, when the product is returned, prepaid, with proof of purchase. Alteration to, misuse of, or improper installation of this product voids the warrant. Curt Manufacturing Inc.'s liability is limited to repair or replacement of products found to be defective, and specifically excludes liability for incidental or consequential loss or damage.

DO NOT EXCEED VEHICLE MANUFACTURER'S RECOMMENDED TOWING CAPACITY.

CAB TO TRAILER CLEARANCE

REMOVAL OF REAR WINDOW ACCESSORIES MAY BE REQUIRED.

TRAILER

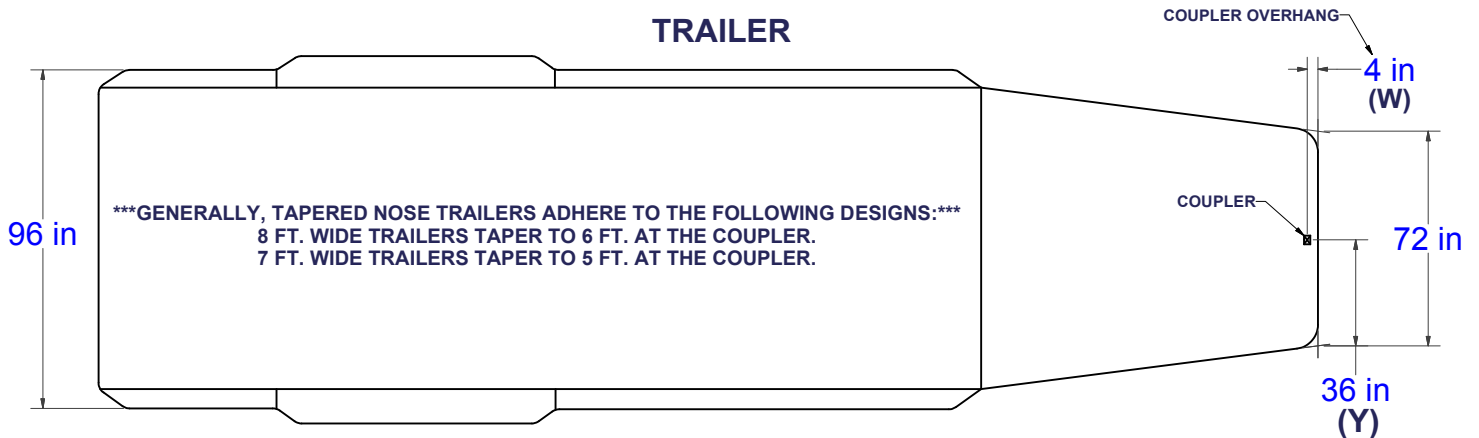

LONG & SHORT TRUCK BEDS

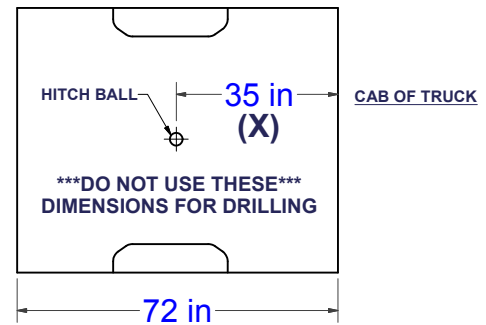
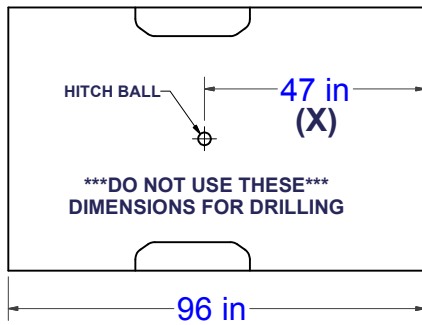

CLEARANCE CALCULATION

$$\begin{matrix} \text{(CAB TO BALL CENTER)} & - & 1/2 \text{ (TRAILER WIDTH)} & = & \text{(MINIMUM CLEARANCE)} \\ \text{(X)} & - & \text{(Y)} & = & \text{(Z)} \end{matrix}$$

IF THERE IS AN OVERHANG FROM THE COUPLER THEN THE EQUATION IS:

$$\text{[(X) - (W)]} - \text{(Y)} = \text{(Z)}$$

IF (Z) IS POSITIVE, TRAILER **WILL NOT** INTERFERE WITH CAB OF TRUCK.
 IF (Z) IS NEGATIVE, TRAILER **WILL** INTERFERE WITH CAB OF TRUCK!!!

EXAMPLE:

STANDARD TRAILER

$$X - Y = Z$$

$$35 - 36 = -1$$

(TRAILER **WILL INTERFERE** WITH CAB)

TRAILER WITH OVERHANG

$$\text{[(X) - (W)]} - Y = Z$$

$$[35 - 4] - 36 = -5$$

(TRAILER **WILL INTERFERE** WITH CAB)

YOUR CALCULATION:

(CAB TO BALL CENTER) _____

(COUPLER OVERHANG) - _____

1/2 (TRAILER WIDTH) - _____

(MINIMUM CLEARANCE) = _____

Curt Manufacturing Inc., warrants this product to be free of defects in material and/or workmanship at the time of retail purchase by the original purchaser. If the product is found to be defective, Curt Manufacturing Inc., may repair or replace the product, at their option, when the product is returned, prepaid, with proof of purchase. Alteration to, misuse of, or improper installation of this product voids the warranty. Curt Manufacturing Inc.'s liability is limited to repair or replacement of products found to be defective, and specifically excludes liability for incidental or consequential loss or damage.