



Warning: On two wheel drive trucks a clearance check must be performed when truck is loaded and unloaded to verify the inverted ball will not interfere with the top of the differential.

Make/Model	Style	Years From	Years To	20K Part#	30K Part#	Foot Notes
CHEVROLET/GMC						
1500 C/K Series	Long Bed	1988	1998	61103	61503	
	Short Bed	1988	1998	61104	61504	
1500 Silverado/Sierra	New Body	2007	2013	61231	61331	
	Classic Body	1999	2007	61241	61341	Z
2500 & 3500 C/K Series	Long Bed (Old Body)	1988	2000	61103	61503	
	Short Bed (Old Body)	1988	2000	61104	61504	
2500HD/3500 Silverado/Sierra		2011	2015	61200	61301	Z
		2001	2010	61241	61341	Z
2500LD Silverado/Sierra	Classic Body	1999	2007	61241	61341	Z
DODGE						
Ram 1500		2002	2008	61219	61319	Z
		1994	2001	61109	61509	
Ram 2500/3500		2003	2012	61129	61529	
		1994	2002	61109	61509	
FORD						
F-150		2004	2013	61221	61321	Z
		1997	2003	61106	61506	
		1980	1996	61105	61505	
F-250	Heritage Edition	2004	2004	61106	61506	
	Old Body	1997	1998	61105	61505	
F-350		1980	1996	61105	61505	
		1997	1998	61105	61505	
F-250/350 Super Duty		1999	2015	61232	61332	Z
F-450 Super Duty	Excluding Cab & Chassis	2008	2011	61232	61332	Z
TOYOTA						
Tundra	Short Bed	2007	2012	61225	n/a	1
UNIVERSAL						
Universal Rail Kit	Raw Finish	n/a	n/a	61102	61502	

*** While Supplies Last**

Footnotes:

Z = No Drill

1 = Do not exceed recommended vehicle towing capacity.



C-1 Gooseneck Folding Hitchball Sub Assembly Kit

C-2CL / C-2CS / C-503 / C-504

Fits 1988-1998 Chevrolet/GMC

Installation Instructions

1. Install cross members from under the truck bed by angling them up from behind the differential over the driveshaft and exhaust up onto the frame rails. Be sure that the prepunched holes are facing upward toward the pickup bed and the vertical legs are facing toward each other.
2. Once the cross members are in position, place the frame mounting plates on the 5/8" welded studs extending from the crossarm ends. Fasten the cross arms to the frame mounting plates using the 5/8" flange nuts provided. Finger tighten only.
Repeat this step for passenger side.
3. Using the 1/2" hardware provided, align the lower two holes in the frame mounting plate with the existing holes in the truck frame. Secure them by inserting the 1/2" Grade 5 bolt and flat washer from the inside of the truck frame and securing them with a 1/2" flange nut. Repeat step 3 for the passenger side.
4. Once sub kit is installed be sure to verify that the cross members and mounting plates are in their proper location. Be sure the rear cross arm is approximately 3" to 6" in front of the rear axle.
5. Now that the sub kit is installed and only finger tight, use the spacer provided to evenly space the cross arms. Once the cross arms are spaced correctly drill a pilot hole through each of the six holes in the cross arms, up through the pick up bed. Place the cutting template inside the pick up bed and align the six pilot holes with the letter A on the template. Use tape and fasten the template to the pickup bed. Once fastened, drill one 1/8" pilot hole through section letter B. Be sure to check for fuel lines brake lines, etc. before drilling.
7. With the pilot holes drilled, use a sabre saw to cut out section C by connecting all the points labeled B.
8. Remove the template and set the C-1 Folding Hitch into place. Using the six pilot holes as a guide, center each of the six holes in the Folding hitch. Using a 21/32" drill bit, drill through each hole down to the predrilled holes in the cross arms.
9. Using the six, 5/8" Grade 5 carriage bolts and flange nuts attach the folding hitch to the cross arms and fasten them securely. Tighten to 115 lb-ft using a torque wrench.
10. After the C-1 has been fastened to the cross arms, the remaining fasteners on the sub assembly kit must be securely fastened. First, secure the cross arms to the frame supports using 115 lb-ft of torque. Second, secure the frame supports to the frame; torque 1/2" hardware to 75 lb-ft.

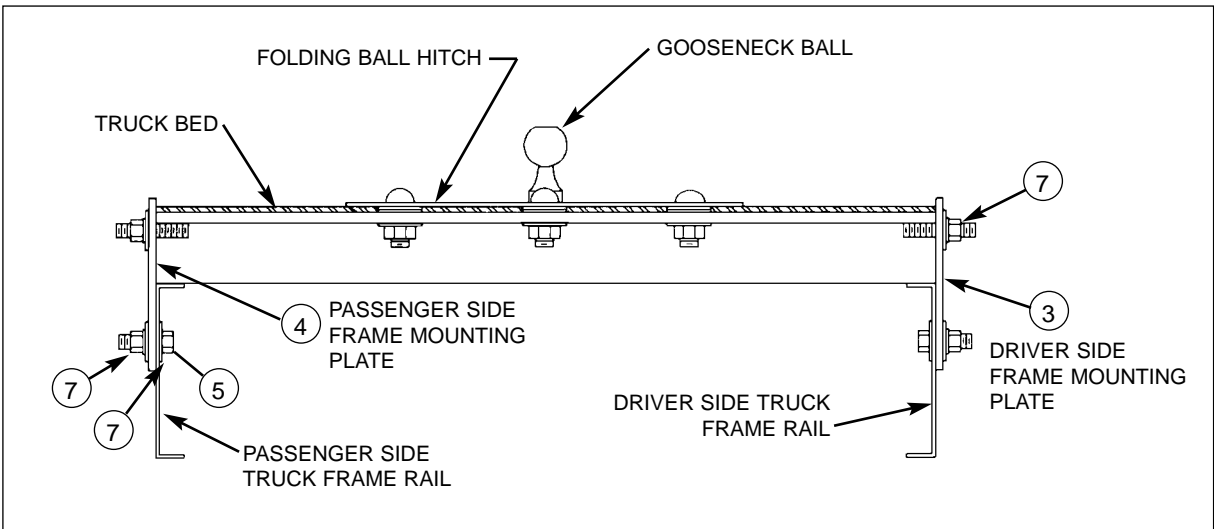
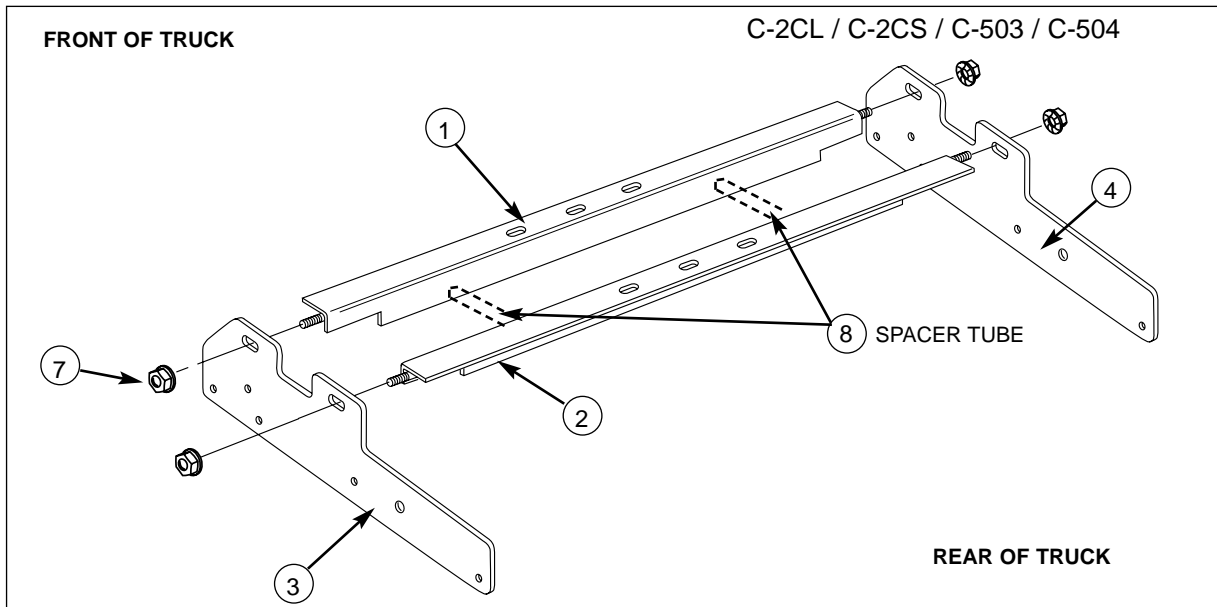

PARTS LIST		
Item #	Qty.	Description
1	1	Front cross member
2	1	Rear cross member
3	1	Driver side mount plate
4	1	Passenger side mount plate
5	4	5/8" x 2" Carriage bolt
6	12	CM-SP27
7	8	5/8" Flange nut
8	1	TubeSpacer