

WARNING: BRAKE, FUEL, AND ELECTRICAL LINES MAY NEED TO BE LOOSENED OR REPOSITIONED TO PROVIDE CLEARANCE FOR NEW HARDWARE. ALL MODELS REQUIRE MODIFICATION OR REMOVAL OF HEAT SHIELDS

INSTALLATION STEPS

****REMOVE SPARE TIRE FOR INSTALLATION****

1. Remove the heat shield located above the rear axle, if equipped. The gas tank heat shield may also need to be cut along the top for some models.
2. Use a 9/16" socket to remove the emergency brake cable support from driver side frame.
3. On 2005 models loosen the (2) bolts on the exhaust hanger mount in front of the rear axle between the exhaust hanger and the truck bed. Lower the exhaust approximately 1/2", insert the 1/2" spacer plate provided and retighten bolts.
4. On 2005 models remove rear exhaust hanger and install exhaust strap 1. Lower exhaust as needed for cross arm clearance.
5. Install cross arms by sliding them into the gap between the truck bed and frame on passenger side. Swing other end between the truck bed and frame gap on driver side as shown in **Figure 1**. **(Note: Make sure cross arms placed in the correct orientation, as shown in Figure 2.)**
6. Hang the side plates from the 5/8" studs extending from the cross arms. Secure each plate with (2) 5/8" flange nuts provided. Finger tight only.
7. Align side plates with the 3/4" slot in the frame. Place the 5/8" carriage bolts through side plate, 1/4" spacers (use spacers as needed to fill the gap between the frame and sideplate), and frame as shown in **Figure 2**. Use a 5/8" flange nut to secure, finger tight only. At this time, place another 5/8" carriage bolt through the other hole in the frame and side plate or drill the hole to fit the 08' - current model trucks. Secure with a 5/8" flange nut and washer as shown. **(Note: Hardware orientation is different on driver side of 2011 Ford Super Duty equipped with a diesel engine. See Figure 2.)**
8. Reinstall the emergency brake cable supports on driver side using 3/8" hex bolts, washers, and flange nut.
9. Rotate the cross arms until they contact the truck bed. Center the rear cross arm studs in the side plate slots as shown in **Figure 3**. Use a 15/16" wrench to tighten the 5/8" flange nuts on the rear cross arm to the side plates. Use the spacer tube provided to evenly space the cross arms. Once evenly spaced tighten the 5/8" flange nuts on the front cross arm. **(Note: Do not tighten front cross arm until cross arms are evenly spaced.)**
10. Drill 1/8" pilot holes through the center of each of the six holes in the cross members up through the pickup bed. From inside the pickup bed, center the six pilot holes with the letter "A" on the cutting template and fasten the template to the bed floor with tape. Once fastened, drill four 1/8" pilot holes through section lettered "B". **(Note: Be sure to check for brake and fuel lines before drilling. Also, be sure the holes are drilled in the lower rib sections of the truck bed as shown in Figure 4.)**
11. With the pilot holes drilled, use a sabre saw to cut out section "C" of the template.

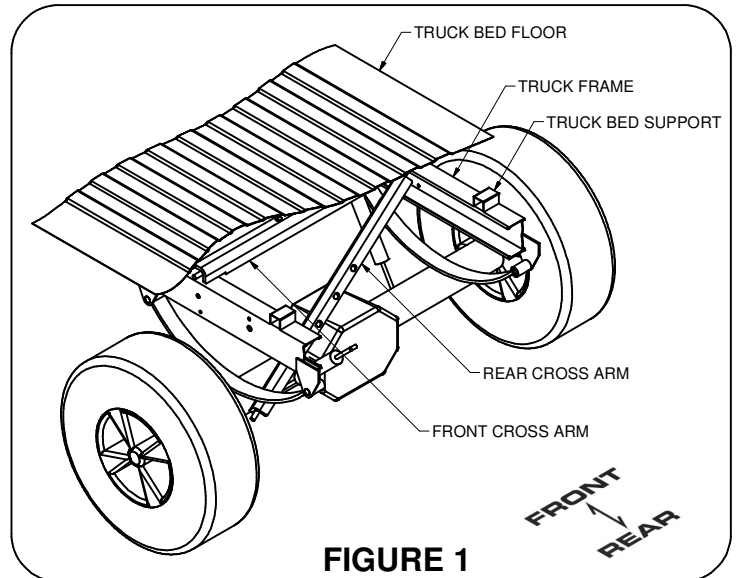

FIGURE 1

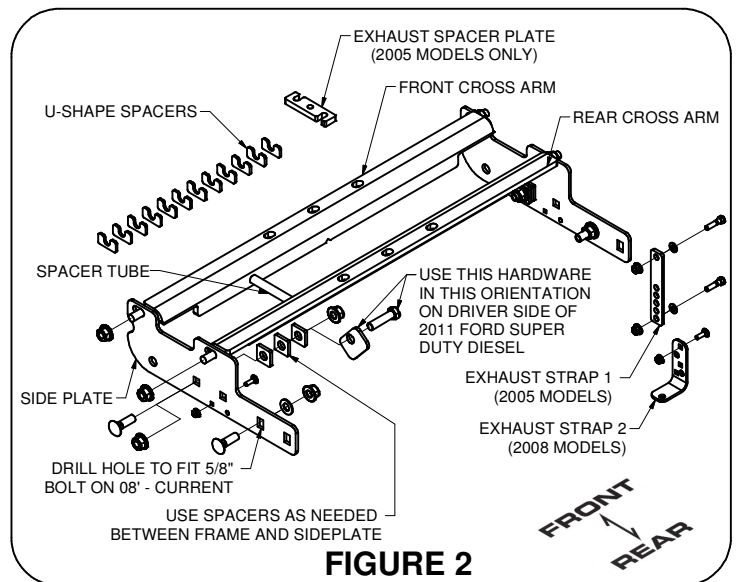

FIGURE 2

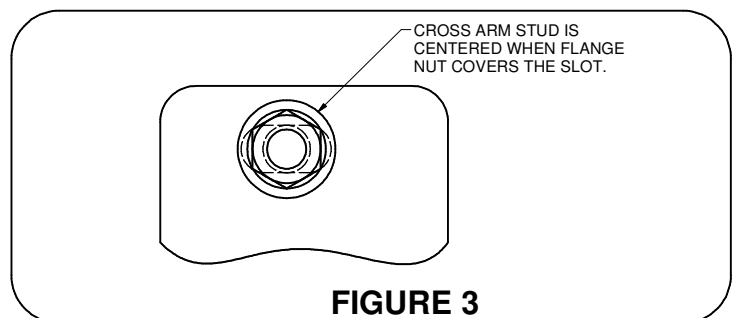

FIGURE 3

INSTALLATION STEPS (CON'T.)

12. Remove the template and set your C-52 folding hitch ball into place. Center the C-52 using the six pilot holes as a guide. Using a 21/32" drill bit, drill out all six holes in the pick up bed floor.
13. Attach the folding hitch ball to the cross arms using the six 5/8" grade 5 carriage bolts and flange nuts provided. Torque bolts to 210 ft-lbs. **Note:** U-SHAPED spacers must be placed under each bolt between cross arms and folding hitch to prevent bed floor from collapsing.
14. After the C-52 has been fastened to the cross arms, the remaining fasteners on the subkit must be torqued. First, torque 5/8" flange nuts on cross arms to the side plates to 210 ft-lbs. Second, torque 5/8" bolts and nuts securing the side plates to the frame to 210 ft-lbs. Third, torque the 3/8" hardware to 45 ft-lbs. Forth, torque 5/16" hardware to 23 ft-lbs.
15. Reattach any brake, fuel, or electrical wires so they have adequate clearance to added fasteners.

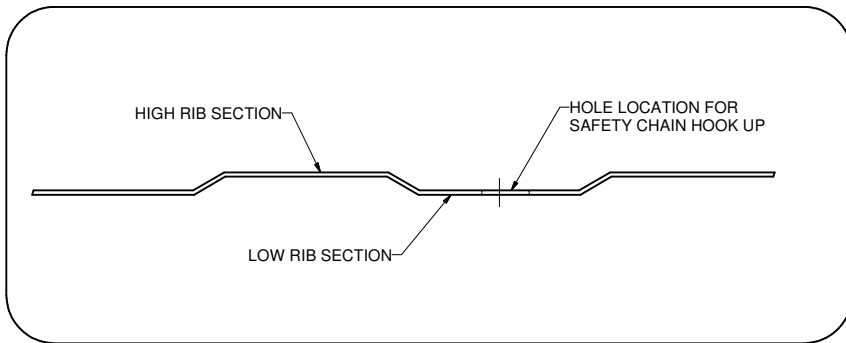
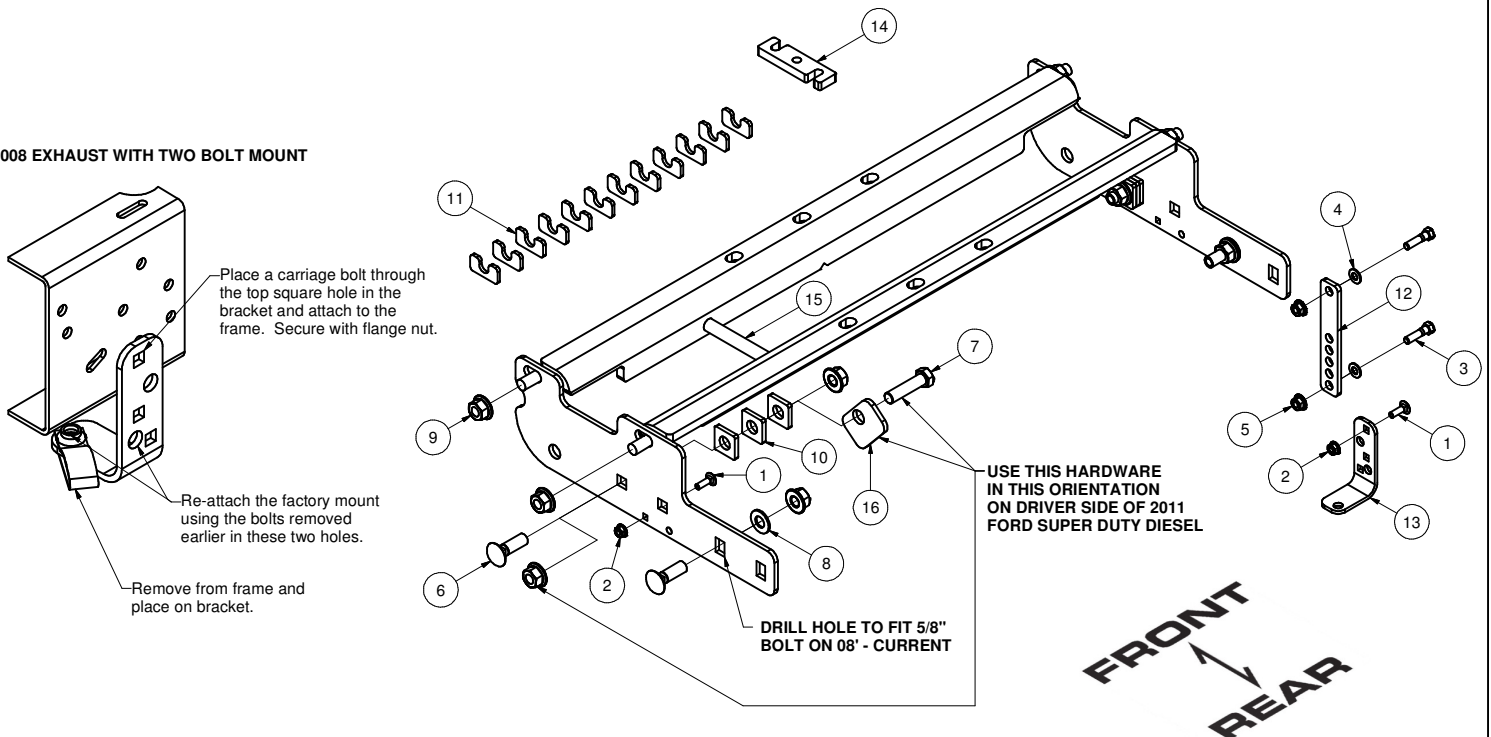

FIGURE 4

Parts List			
ITEM	QTY	PART NUMBER	DESCRIPTION
1	2	5/16-18 x 1	CARRIAGE BOLT
2	2	5/16-18	HEX FLANGE NUT
3	2	3/8-16 X 1 1/2	HEX BOLT
4	2	3/8"	WASHER
5	2	HFN3816	HEX FLANGE NUT
6	4	5/8-11 x 2	CARRIAGE BOLT
7	1	5/8 - 11 x 2 1/2 HEX	HEX BOLT
8	2	5/8	WASHER
9	8	5/8-11	HEX FLANGE NUT
10	6	CM-SP15	.250 x 1.50 x 1.50" SPACER
11	12	CM-SP27	.188 x 1.00 x 2.00" U-SHAPE SPACER
12	1	CM-ES1	.250" EXHAUST STRAP 1
13	1	CM-ES2	.188" EXHAUST STRAP 2
14	1	CM-ES3	PLATE .500" A-36 H.R.
15	1	CM-TS	.706 DIA.TUBE SPACER
16	1	CM-SP139	.250" SPACER

2008 EXHAUST WITH TWO BOLT MOUNT



Curt Manufacturing Inc., warrants this product to be free of defects in material and/or workmanship at the time of retail purchase by the original purchaser. If the product is found to be defective, Curt Manufacturing Inc., may repair or replace the product, at their option, when the product is returned, prepaid, with proof of purchase. Alteration to, misuse of, or improper installation of this product voids the warranty. Curt Manufacturing Inc.'s liability is limited to repair or replacement of products found to be defective, and specifically excludes liability for incidental or consequential loss or damage.



Warning: On two wheel drive trucks a clearance check must be performed when truck is loaded and unloaded to verify the inverted ball will not interfere with the top of the differential.

Make/Model	Style	Years From	Years To	20K Part#	30K Part#	Foot Notes
CHEVROLET/GMC						
1500 C/K Series	Long Bed	1988	1998	61103	61503	
	Short Bed	1988	1998	61104	61504	
1500 Silverado/Sierra	New Body	2007	2013	61231	61331	
	Classic Body	1999	2007	61241	61341	Z
2500 & 3500 C/K Series	Long Bed (Old Body)	1988	2000	61103	61503	
	Short Bed (Old Body)	1988	2000	61104	61504	
2500HD/3500 Silverado/Sierra		2011	2015	61200	61301	Z
		2001	2010	61241	61341	Z
2500LD Silverado/Sierra	Classic Body	1999	2007	61241	61341	Z
DODGE						
Ram 1500		2002	2008	61219	61319	Z
		1994	2001	61109	61509	
Ram 2500/3500		2003	2012	61129	61529	
		1994	2002	61109	61509	
FORD						
F-150		2004	2013	61221	61321	Z
		1997	2003	61106	61506	
		1980	1996	61105	61505	
F-250	Heritage Edition	2004	2004	61106	61506	
	Old Body	1997	1998	61105	61505	
F-350		1980	1996	61105	61505	
		1997	1998	61105	61505	
F-250/350 Super Duty		1980	1996	61105	61505	
		1999	2015	61232	61332	Z
F-450 Super Duty	Excluding Cab & Chassis	2008	2011	61232	61332	Z
TOYOTA						
Tundra	Short Bed	2007	2012	61225	n/a	1
UNIVERSAL						
Universal Rail Kit	Raw Finish	n/a	n/a	61102	61502	

*** While Supplies Last**

Footnotes:

Z = No Drill

1 = Do not exceed recommended vehicle towing capacity.