

INSTALLATION INSTRUCTIONS

VEHICLE

HITCH NO.

TOYOTA 4RUNNER

75145

33023

EQUIPMENT REQUIRED:

WIRING ACCESS LOCATION: SUV3, SUV4

DRILL BITS: 1/2

HITCH REQUIRES 1/2" PIN AND CLIP IF STABILIZING PIN IS NOT INSTALLED.

WRENCHES: (TIGHTEN ALL FASTENERS WITH TORQUE WRENCH) 9/16, 3/4

DO NOT EXCEED LOWER OF
TOWING VEHICLE MFR'S RATINGS OR

HITCH TYPE	MAX GROSS TRLR WT(LB)	MAX TONGUE WT(LB)
WEIGHT DISTRIBUTING	5000	550
WEIGHT CARRYING BALL MOUNT	5000	500

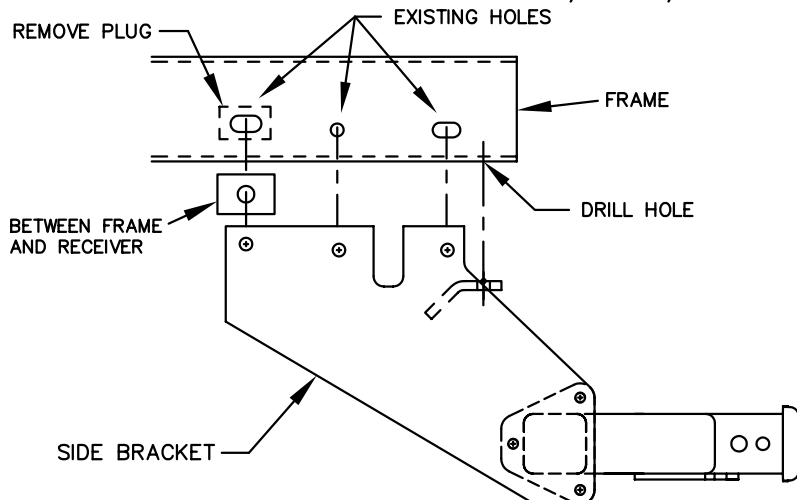
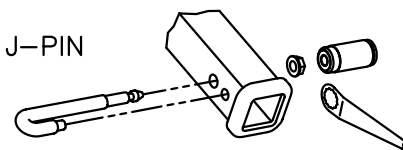

FIGURE 1.

OPTIONAL LOCKING STABILIZING PIN

J-PIN



(Order Separately)

NOTE: FASTENERS TYPICAL BOTH SIDES

NOTE: SPARE TIRE MAY HAVE TO BE REPOSITIONED SLIGHTLY FORWARD TO AVOID CONTACT WITH RECEIVER TUBE.

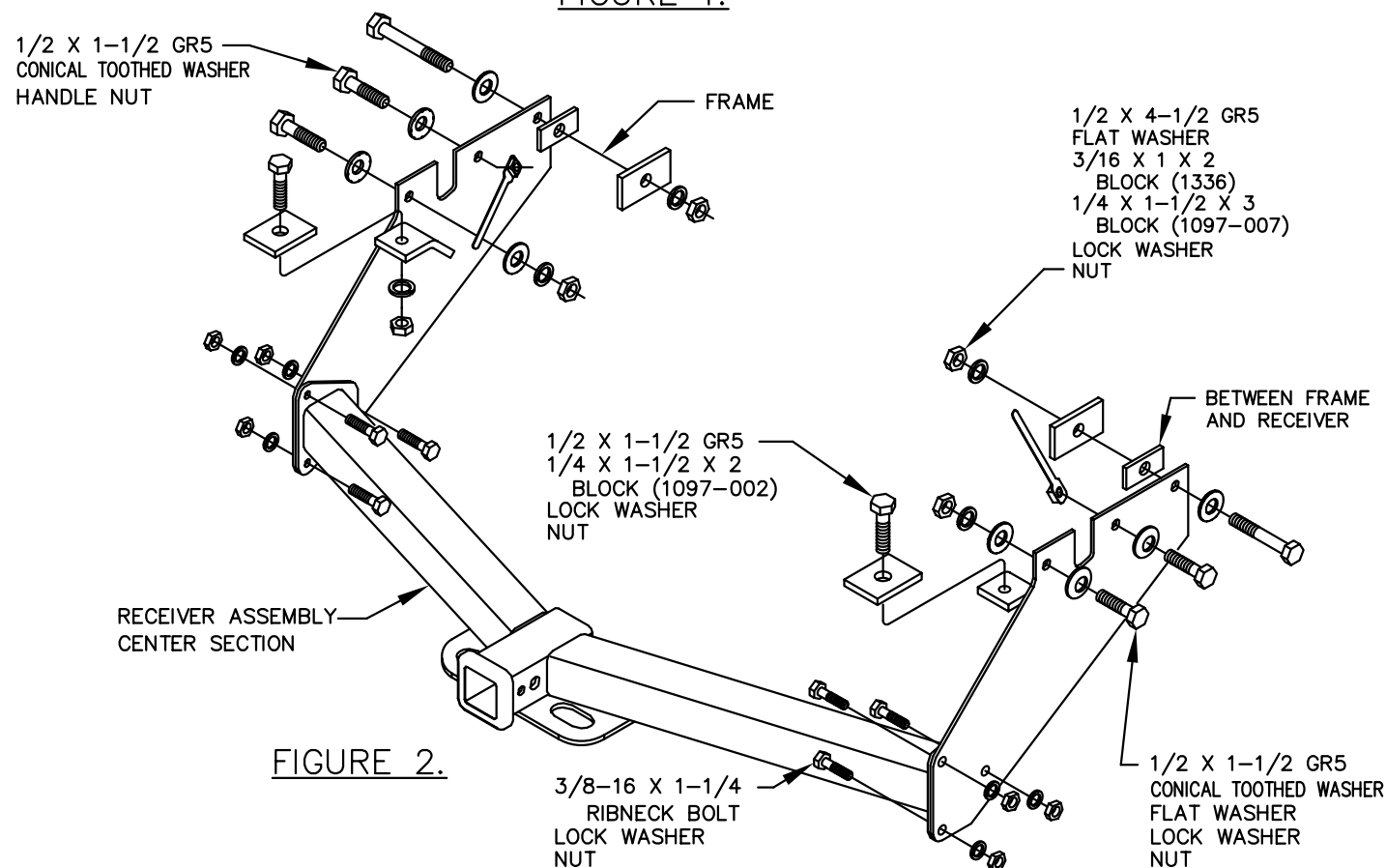

FIGURE 2.

1. REMOVE BLACK PLASTIC PLUG WHICH COVERS HOLE IN OUTBOARD VERTICAL SURFACE ON FRAME, EACH SIDE.
2. RAISE EACH SIDE BRACKET INTO POSITION LINING UP WITH EXISTING HOLES ON THE OUTSIDE OF THE FRAME. THE HORIZONTAL PORTION OF THE SIDE BRACKETS SUPPORT WILL BE LOCATED ON THE BOTTOM OF THE FRAME.
3. **FORWARD ATTACHMENT:** PLACE 3/16 X 1 X 2 BLOCK (1336) BETWEEN HITCH SIDE BRACKET AND FRAME. INSTALL 1/2-13 X 4-1/2 HEX BOLT THROUGH FLAT WASHER, SIDE BRACKET, 3/16 X 1 X 2 BLOCK (1336) AND FRAME. FASTEN WITH 1/4 X 1-1/2 X 3 BLOCK (1097-007), LOCK WASHER AND NUT.
4. **CENTER ATTACHMENT:** INSTALL 1/2-13 X 1-1/2 HEX BOLT THROUGH CONICAL TOOTHED WASHER, SIDE BRACKET AND FRAME. FASTEN WITH HANDLE NUT.
5. **REAR ATTACHMENT (HORIZONTAL):** INSTALL 1/2-13 X 1-1/2 HEX BOLT THROUGH CONICAL TOOTHED WASHER, SIDE BRACKET AND FRAME. FASTEN WITH FLAT WASHER, LOCK WASHER AND NUT.
6. **REAR ATTACHMENT (VERTICAL):** USING HOLE IN SIDE BRACKET SUPPORT AS A GUIDE, DRILL 1/2" HOLE IN BOTTOM OF BOTH FRAME RAILS. INSTALL 1/2-13 X 1-1/2 HEX BOLT THROUGH 1/4 X 1-1/2 X 2 BLOCK (1097-002), FRAME AND SIDE BRACKET SUPPORT. FASTEN WITH LOCK WASHER AND NUT.
7. INSTALL CENTER SECTION OF HITCH WITH SIX (6) 3/8 RIBNECK BOLTS, 3/8 LOCK WASHERS, AND 3/8 NUTS. TIGHTEN NUTS UNTIL BOLT HEADS SEAT.

TIGHTEN 3/8-16 GR5 FASTENERS TO 35 LB.-FT.

TIGHTEN 1/2-13 GR5 FASTENERS TO 75 LB.-FT.

TIGHTEN HANDLE NUT FASTENERS TO 50 LB.-FT.

THIS PRODUCT COMPLIES WITH SAFETY SPECIFICATIONS AND REQUIREMENTS FOR CONNECTING DEVICES AND TOWING SYSTEMS OF THE STATE OF NEW YORK AND V.E.S.C. REGULATION V-5.

APPROX WEIGHT (LB.)

50.8

FASTENER KIT NO.

F75145

NOTE: Check hitch frequently, making sure all fasteners and ball are properly tightened. If hitch is removed, plug all holes in trunk pan or other body panels to prevent entry of water and exhaust fumes. A hitch or ball which has been damaged should be removed and replaced. Observe safety precautions when working beneath a vehicle and wear eye protection. Follow car maker's specs for maximum trailer weight and tongue weight. Do not cut access or attachment holes with a torch.

TOWING PRODUCTS
Plymouth, Michigan