

DEMCO

Doing Our Best to Provide You the Best

TB20050, Rev 4
01/19

AFO Supplemental Braking System



DEMCO

OPERATOR MANUAL

INTRODUCTION

Thank you for purchasing Air Force One: the most advanced supplemental braking system available. When installed correctly, this system will provide years of maintenance and adjustment-free service. These installation instructions are designed to guide you through the installation of your new braking system. The installation is vitally important to the proper operation and safety of both the end user, and those on the road. **It is imperative that these instructions be read in their entirety before any part of the installation is attempted.** This will allow for a proper understanding of the system as a whole, and will also result in a much neater, professional installation. We have compiled these instructions based on the feedback from technicians, installers, and individual customers. If at any time you do not feel 100% comfortable and confident throughout the installation, you must contact the Demco toll-free tech support line immediately at 800-543-3626 to either receive an answer to your questions or obtain the location of the nearest qualified technician for assistance.

WARRANTY POLICY, OPERATOR MANUALS & REGISTRATION

Go online to www.demco-products.com to review Demco warranty policies, operator manuals and register your Demco product.

TABLE OF CONTENTS

Inventory of Parts	3
Things to Know	7
Coach Installation	8
Towed Vehicle Installation	16
Testing the Installation	27
Operation.....	27
Wiring Diagram.....	28
Plumbing Diagram.....	29
Warranty Information.....	30

6267 SMALL PARTS KIT

ITEM	PART #	QTY	DESCRIPTION
1	05744	2	TERMINAL RING .25 18-20GA BLUE
2	07378	4	CONNECTOR BUTT
3	16017	1	FUSE 10 AMP ATC
4	16021	1	FUSE HOLDER
5	16025	1	TERMINAL 3-WAY CRIMP
6	16027	2	.375 X .50 BARBED ADAPTER
7	16064	2	CLAMP WIRE .25 VINYL COATED
8	16126	2	CHECK VALVE .375 BARBED
9	16128	1	FTG TEE .375 X 3 BARBED
10	6266	1	HYDRO-BOOST KIT
11	B6H	2	CLAMP, GEAR, SS .375 HOSE

Please order replacement parts by **PART NO.** and **DESCRIPTION**



6266 HYDRO-BOOST KIT

ITEM	PART #	QTY	DESCRIPTION
1	16063	1	NUT, 5.8 ACORN
2	16141	1	RUBBER PLUG
3	16142	1	PLUG .375 BARBED

Please order replacement parts by **PART NO.** and **DESCRIPTION**

6211 BREAKAWAY CABLE KIT

ITEM	PART #	QTY	DESCRIPTION
1	16050	2	CARABINER HOOK 6 mm
2	16138	1	CABLE BREAKAWAY COILED

Please order replacement parts by **PART NO.** and **DESCRIPTION**



6214 AIR FORCE ONE QUICK CONNECT KIT F/ TOWED

ITEM	PART #	QTY	DESCRIPTION
1	02772	2	NUT, .25NC LOCK NYLON INSERT
2	04055	2	.25-20NC X 1 GR5 HEX
3	16069	1	AFO CAP PLUG (SMALL)
4	16100	1	L-BRACKET
5	16122	2	WASHER, .25 FENDER
6	16133	1	QUICK CONNECT MALE PLUG .125 NPT
7	16136	1	FTG ELBOW PUSHLOCK .25 X .125 FEMALE NPT
8	16139	1	FILTER CLOSE .125 NPT

Please order replacement parts by PART NO. and DESCRIPTION



6237 AFO TOWED INSTALL KIT

ITEM	PART #	QTY	DESCRIPTION
1	16110	10	CABLE ZIP TIE 8"
2	16165	10	BROWN WIRE (SOLD PER FOOT, 10' REQUIRED)
3	6211	1	BREAKAWAY CABLE
4	6214	1	AFO QUICK CONNECT KIT f/ TOWED
5	6265	1	BREAKAWAY KIT
6	6267	1	AFO SMALL PARTS KIT

Please order replacement parts by PART NO. and DESCRIPTION



6210 AIR FORCE ONE AIR CYLINDER KIT

ITEM	PART #	QTY	DESCRIPTION
1	6210	1	AIR CYLINDER
2	16127	1	CABLE ANCHOR
3	16151	3	SCREW 14 X 1.00 HEX HD WASHER DRILL TAP
4	16707-76	1	REINFORCEMENT PLATE F/ CABLE ANCHOR

Please order replacement parts by PART NO. and DESCRIPTION



6235 AIR FORCE ONE OPERATING UNIT



6213 COACH NOTIFICATION KIT



ITEM	PART #	QTY	DESCRIPTION
1	05744	1	TERMINAL RING .25, 18-20 GA. BLUE
2	07378	3	CONNECTOR BUTT
3	16024	1	TERMINAL T-TAP CONNECTOR
4	16025	1	TERMINAL 3-WAY CRIMP
5	16028	1	TERMINAL MALE SPADE .25
6	16144	1	LED LIGHT
7	16146	5	WIRE BLACK (SOLD PER FOOT, 5' REQUIRED)
8	16147	5	WIRE RED (SOLD PER FOOT, 5' REQUIRED)

Please order replacement parts by PART NO. and DESCRIPTION

6248 QUICK CONNECT KIT F/ COACH

ITEM	PART #	QTY	DESCRIPTION
1	02772	2	NUT, .25NC LOCK NYLON INSERT
2	04055	2	.25-20NC X 1 GR5 HEX
3	16068	1	AFO PLUG LARGE
4	16100	1	L BRACKET
5	16120	1	FTG ELBOW PUSHLOCK .25 TUBE X .125 MALE NPT
6	16121	1	QUICK DISCONNECT f/ AFO
7	16122	2	WASHER. .25 FENDER

Please order replacement parts by PART NO. and DESCRIPTION



6238 COACH INSTALL KIT



ITEM	PART #	QTY	DESCRIPTION
1	00059	4	WASHER, FLAT .375
2	00914	2	BOLT, .375 NC X 1.50 HEX HEAD GR5
3	02592	2	NUT, .375NC NYLON LOCK
4	16129	1	FTG PUSHLOCK .25 X .375
5	16130	1	FTG TEE PUSHLOCK .375 X .375 X .25
6	16131	1	FTG TEE PUSHLOCK .625 X .625 X .25
7	16132	1	FTG TEE .375 STREET EXTRUDED
8	6248	1	QUICK CONNECT KIT f/ COACH

Please order replacement parts by PART NO. and DESCRIPTION

6212 AIR FORCE ONE COILED AIR JUMPER KIT

ITEM	PART #	QTY	DESCRIPTION
1	16121	1	QUICK DISCONNECT
2	16133	1	QUICK CONNECT MALE PLUG, .125 NPT
3	16134	1	COILED HOSE .25 X 7 FT
4	16135	2	FTG, .25 COMPRESSION X .125 MALE NPT

Please order replacement parts by **PART NO.** and **DESCRIPTION**



6236 AIR FORCE ONE AIR TANK ASSEMBLY



380RB



**7' Length of 3/8" Vacuum Hose
(sold per foot)**

16114



**40' - 1/4" DOT Air Line
(sold per foot)**

Air Force One is designed to provide proportionate braking effort in the towed vehicle by applying proportioned air based on the pressure in the coach's braking system to the Air Force One braking system.

Be sure to have your towed vehicle's brakes inspected for wear before towing. In most cases towed vehicles do not accrue mileage on the odometer while in tow, resulting in the brakes needing to be serviced before the odometer would dictate. For most vehicles it is recommended to have the brakes inspected/replaced every 20,000-30,000 miles. **You must combine towing and driving mileage when determining the interval.**

Federal Motor Vehicle Safety Standard (FMVSS) 121 requires that a separate air circuit and flow protection valve be installed when the towing vehicle's air supply is used for a supplemental braking system. Air Force One is the only air brake system that supplies these components as part of the installation kit. Should there be any breach in the supplemental air connection, the air supply will be shut off: allowing you to stop your coach safely in every situation, even during a breakaway.

The provided coach installation was designed in cooperation with Mike O'Neil at Spartan Chassis and meets the operational requirements of **Spartan** (per Mike O'Neil) and **Freightliner** (per Tony Sipple). At time of publication, Spartan and Freightliner are the only chassis with specific guidelines other than FMVSS 121.

In the event of a breakaway, the reserve-air supply (located within the operating unit) is used to apply the towed vehicle's brakes. The towed vehicle's brakes remain applied until the break-away pin is replaced. To be sure that the breakaway tank is charged, you should apply the **coach's brake pedal** completely for **3 seconds** after the coach has been allowed to completely 'air-up.'

Be sure to place the provided dust cap on the vehicles' air connections. Failure to do so **WILL** result in improper functioning of the braking unit. Note: If a different cap is used on towed vehicle it must be allowed to vent, allowing heated air to escape during normal driving. Failure to do so **WILL** result in damage to the towed vehicle. The brass couplers may corrode depending on the environment in which it was operated. Should they become difficult to operate, lubricate with spray silicone and cycle until the couplers move freely.

Corroded couplers may not seat properly resulting in disconnect while in tow.

Step 1: Mount the Coach Air Tank Assembly

Fig 6.1



1. Select an appropriate location for the Coach Air Connection Assembly. The air lines to be connected must not be near any direct heat source or moving parts and must not be routed in such a manner that they will kink. In many cases the Coach Air Connection Assembly may be mounted to the same cross-member as the coach's relay-valve assembly. Note: The diaphragm on the bottom of the relay valve must not face upward (See Fig 6.1)

Step 2: Supply-Air Connection

Fig 6.2



1. Locate the coach's supply air hose. This line goes from the service relay valve to the braking air tank. It is 5/8" in outside diameter. Although it is normally green, it may be any color. Do not confuse this hose with the treadle-valve hose. This line is only 3/8" in outside diameter and should not be tampered with. Fig 6.2
2. Cut this line with an appropriate hose cutter so that the cut is straight and clean. A straight, clean edge is necessary to prevent leaks in the coach's air system. **Remember, you must drain the coach's air tanks before cutting this line.**
3. Attach the provided 5/8" push lock tee.

Step 3: Metered-Air Connection

Locate the spring-brake/quick-release valve. In most applications it is mounted directly below the service brake relay. In most applications, the metered-air port is directly in the center of the top of the valve (just like on the Demco assembly).

The spring-brake/quick-release valve can be quickly identified by locating the port on the air can labeled "spring" or "emergency" and following the rubber hose up to the valve.

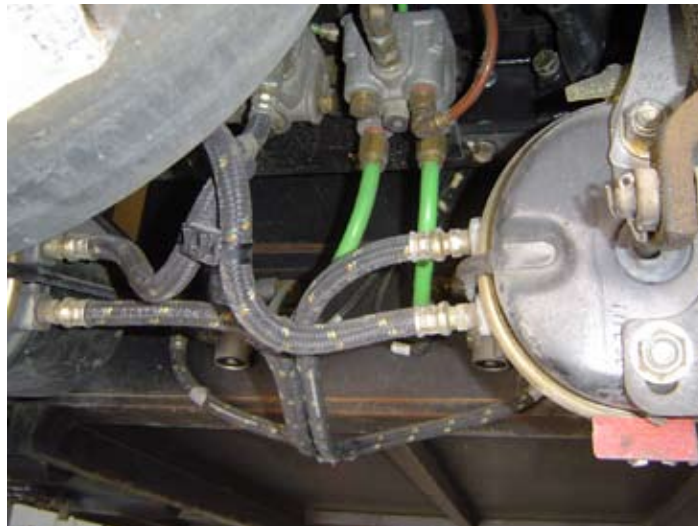

COACH INSTALLATION

MOST FREIGHTLINERS:

The valve is connected via a 3/8" airline below the service-brake relay valve, simply cut the hose and insert the tee using the provided pushlock fittings. Fig 7.1. Attach the provided 3/8" push lock tee.

Fig 7.1



Spartan:

Some Spartans have a similar setup to most Freightliners. Some (such as the K2) thread the valve directly into the bottom of the service relay valve Fig 7.2. In this case, the Spartan recommended procedure is to remove the connection between the relay-valve assembly and the quick-release valve and insert the tee with the 3/8" close nipple between them. To do this, remove the two lines going from the spring-brake valve to the air cans on either side of the drive axle. Caution - It is possible for the quick release valve to un-thread incorrectly resulting in disassembly of the valve. It is safest to use a wrench on the hex nipple to loosen them. The nipple should remain connected to the quick release valve. It is usually necessary to first remove the lines from the air cans when removing the valve, as this will allow it to freely turn. Caution - If you remove both lines from the air can, be sure to replace them correctly. Note: The right and left air-can hose locations are reversed.

Important: We have observed cases where the addition of the tee and nipple as prescribed by the Spartan Recommended Procedure has lowered the quick release valve to the point of impacting the drive-shaft or other drivetrain components. Such impact could cause non-warranted catastrophic failure in the braking system. Be sure there is sufficient clearance after the addition of the tee and nipple. Remember to take into consideration suspension travel over sharp bumps and terrain, and also the air suspension dropping. As a general rule 2.5" or greater is acceptable. If sufficient clearance is not available between the quick-release valve and other chassis components when the air is released from the air bags of the coach, or if you are uncomfortable with the Spartan Recommended Procedure, you must call the Demco Help Line at 800-543-3626 or Spartan Chassis at 517-543-6400.

Fig 7.2



COACH INSTALLATION

SPARTAN WITH TAG AXLE:

Locate the tag axle relay valve. The Valve is normally directly above the tag axle. Remove the 3/8" NPT pipe plug and thread the provided 3/8" NPT x 1/4" tube push lock fitting in its place Fig. 7.3.



Fig. 7.3

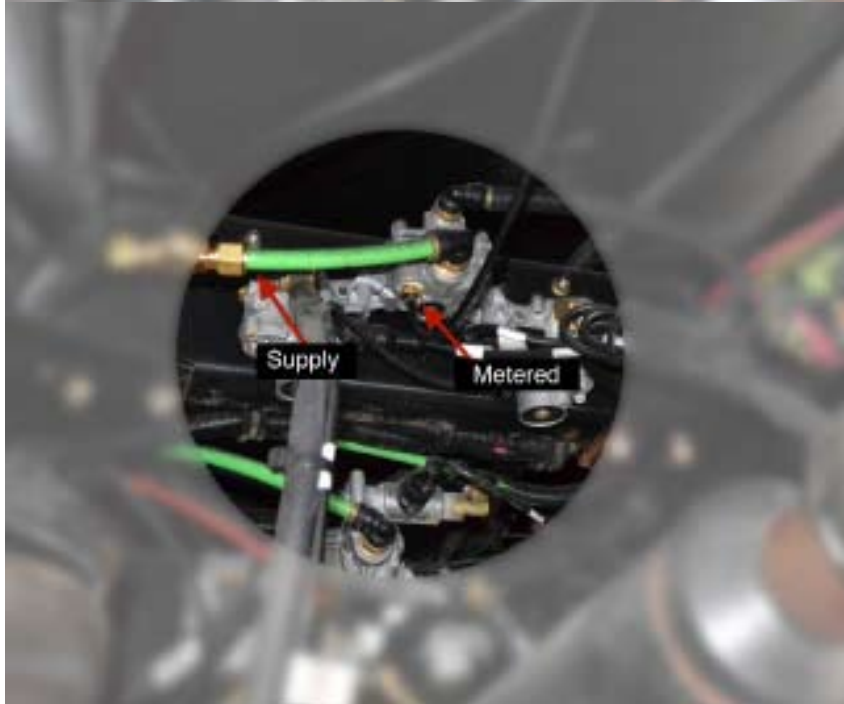

Roadmaster:

Some Roadmasters (especially older models) have a similar configuration to the Freightliners. Most (especially newer models) have the service relay valve (for the supply air connection) in front of the drive axle and the spring brake valve behind the drive axle. In this case the spring brake valve is mounted to the frame cross member. The correct line goes from the top surface of the relay valve directly to the driver's side frame rail. It is a 3/8" line and is normally red in color.

Tiffin:

Starting in 2008 Tiffin Motorhomes began using their own proprietary chassis on many of their coaches. Tiffin coaches incorporate an inversion relay valve rather than a conventional spring brake valve. The ports on the valve are numbered. Either port 41 or 42 will work for the Air Force One system. In this case the port is NOT on the top of the valve. Select the line in either port that is 3/8" so it will work with the provided fittings Fig 8.1. Any further questions may be directed to the Demco Help Line at 800-543-3626, or Brad Warner of Tiffin at 256-356-8661 ext. 2267.

Fig 8.1

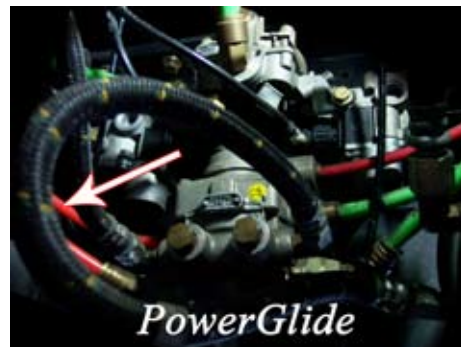
**DynaMax:**

In most cases the DynaMax (Country Coach) chassis has two valves mounted side-by-side. In some cases the service brake relay is on the right (Fig 8.2) and other times it's on the left. In either case the metered line goes from the bottom of the service valve to the top of the spring-brake valve.

Fig 8.2

**Others:**

Virtually all other chassis will fall into one of the above configurations; however, if there are any questions or concerns contact the Demco Help Line at 800-543-3626.

Step 4: Route the Air Line

1. Straighten out the ¼" DOT air hose behind the coach.
2. Route the air hose to the "Coach Air Tank Assembly" being careful to avoid sharp bends, moving parts, and any heat source. Secure it with ties. NOTE: It is often helpful to follow existing wiring harnesses that are typically on the passenger-side frame rail.

Step 5: Plumbing

When connecting the pushlock connectors, use the following method: **1.** Push the air hose in until there is resistance. **2.** Press firmly to be sure that the air line locks fully into place. These fittings are tight, and the hose will snap into place with two "clicks."

Note: Should you find it necessary to remove an air hose, push the air hose in with one hand, push on the outside ring of the pushlock connector with the other hand, and then pull the air hose out. The ring will release the air hose.

1. Using the provided ¼" DOT air hose, connect the supply air (from Step 2) to the pushlock fitting on the pressure-protection valve on the "Coach Air Connection Assembly" Fig 9.1.

Fig 9.1



2. Connect the metered air (from Step 3) to the pushlock connector on the Air Force One relay valve labeled "SER." Fig 9.2.

Fig 9.2



3. Connect the towed-vehicle air hose (from Step 4) to the pushlock connector on the relay valve labeled "DEL." Fig 9.3

Fig 9.3

**Step 6: Mount the Female "L" Bracket**

1. Using the provided hardware, mount the female "L" bracket to the back of the coach as close to the center as possible. Make sure it is not the lowest point so that it is protected from being bottomed-out.



TOWED VEHICLE INSTALLATION

MOUNTS & CONNECTIONS

Step 1: Mount the Operating Unit

1. Select a suitable location for the operating unit in the engine compartment. It must be away from any extreme heat source and the connections must be easily accessible. The unit can often be installed behind the grill provided it doesn't restrict air flow to the radiator. Moisture will not harm the unit, but it should not be in the direct path of rainwater or road spray. Figures 10.1 & 10.2.
2. Secure the box with wire ties through the mounting flanges on the box. Be sure that the weight of the box is supported, and secured tightly in place.



Fig 10.1



Fig 10.2

Step 2: Mount the Male "L" Bracket

1. Using the provided hardware, mount the male "L" bracket to front of the towed vehicle as close to the center as possible. If the coach's "L" bracket was offset, offset the towed's to the same side if possible.
2. Route a length of DOT air hose from the "L" bracket to the operating unit and connect it to the pushlock connector that is labeled "Air In".

Step 3: Mount the Breakaway Switch

1. Mount the breakaway switch to the front of the towed vehicle as close to the center of the towed vehicle as possible using the provided hardware. In many cases it can be mounted to the front fascia in a manner that allows it to turn 90* when not in tow. Figures 10.2 & 10.3

Fig 10.2



Fig 10.3



1. Insert the plug into the switch. This will prevent dirt and water from getting into the switch.
 2. Using the provided 3-way crimp-connector, attach the orange/black wire to the fuse holder. The other side of the 3-way crimp connector will be used to power the reed switch in step 7. Attach the other end of the fuse holder to a 12 volt power source in the towed vehicle. **DO NOT PUT THE FUSE IN.**
 3. The blue wire is attached to one of the black wires from the operating unit.
 4. At this time attach the other black wire from the operating unit to a frame ground.
- *The breakaway system will not function until the operating unit has been charged with air from the coach.**

Step 4: Go Through the Fire wall

Locate the main-wire-harness grommet of the car or another suitable place and route the ¼" air hose into the passenger compartment Fig 11.1. One end of this hose will go to the actuating cylinder, and the other end will go to the connector labeled "air out" on the operating unit under the hood.

Fig 11.1



TOWED VEHICLE INSTALLATION

Step 5: Make the Vacuum Connection

First, locate the vacuum line coming from the brake booster and determine its size. Then, select from one of the following options.

Note: This portion of the installation is for vehicles with vacuum-assisted brakes **ONLY**. If you have hydro-boost brakes see page 21. If you are uncertain of your vehicle's braking configuration, call the Demco Help Line for assistance.

Some newer Ford products incorporate two vacuum lines from the booster and require an additional check valve. Contact the Demco Help Line for details.

SPECIAL CONCERNS

1. There are **TWO** check valves that are going to be installed.
 - a. The Engine Check Valve will be installed in the following orientation: Engine, Engine Check Valve [black/green], Tee, Booster. Fig 12.2
 - b. The Unit Check Valve will be installed in the following orientation: Operating Unit, Unit Check Valve [black/green], Tee.

Fig 12.1



Fig 12.2



2. Exercise care in routing the hose so that no kinks, sharp edges, heat, etc., will effect the operation of the system.
3. Lubricate the check valve and tee with a small drop of dish soap or silicone spray. This will help them slide easily into the vacuum hose.

11/32 - 3/8 I.D. Hose Size (does not require hose clamps)

1. Locate the towed vehicle's existing vacuum hose and determine where the check valve and the tee will be inserted.
2. Cut the towed's existing vacuum hose where the Engine Check Valve will be inserted and install the check valve. Take care not to cut too close to a bend in the hose that will not allow the check valve to be fully inserted into the hose. (Black end toward the motor).
3. Cut the hose where the tee will be inserted and install the tee. Take care not to cut too close to a bend in the hose that will not allow the tee to be fully inserted into the hose.
4. Slide the provided vacuum hose onto the barbed tee, route the vacuum hose to the operating unit, and slide it over the barbed fitting on the operating unit. (stay away from sharp edges, heat sources, and kinks)
5. Lastly, cut the vacuum line approximately 3 inches from the operating unit and insert the Unit Check Valve in line (Black end toward the operating unit).

HARD PLASTIC VACUUM LINES

1. Cut a two inch length of hose from the provided 3/8" vacuum hose. Slide one end onto the green end of the check valve. Insert the tee into the other end.
2. Cut another two inch length of hose and insert the open end of the tee into it. (The open end of the hose will slip over the smaller hard plastic tubing).
3. Cut another length of hose and insert the open (black end) of the check valve.
3. Cut out a portion of the existing hard plastic tubing and slip the open ends of the hose and hose clamps over the plastic tubing. Make sure the black end of the check valve is toward the motor.
4. Put the enclosed clamps on the hose that the hard plastic tubing is inserted into (do not overtighten).
5. Slide the provided vacuum hose onto the barbed tee, route the vacuum hose to the operating unit, and slide it over the barbed fitting on the operating unit. (stay away from sharp edges, heat sources, and kinks)
6. Lastly, cut the vacuum line approximately 3 inches from the operating unit and insert the Unit Check Valve in line (Black end toward the operating unit).

Fig 13.1



TOWED VEHICLE INSTALLATION

1/2-5/8 I.D. VACUUM LINES

1. Cut a two inch length of hose from the provided 3/8" vacuum hose. Slide one end onto the green end of the check valve. Insert the tee into the other end.
2. Cut another two inch length of hose and insert the open (black) end of the check valve. Slide the hose adaptor into the other end.
3. Cut another two inch length of hose and insert the open end of the tee into it. Slide the other hose adaptor into the other end.
4. Cut out a portion of the existing larger vacuum hose out and slip adaptors and hose clamps into the open ends of the hose. Make sure the black end of the check valve is toward the motor.
5. Slide the provided vacuum hose onto the barbed tee, route the vacuum hose to the operating unit, and slide it over the barbed fitting on the operating unit. (stay away from sharp edges, heat sources, and kinks)
6. Lastly, cut the vacuum line approximately 3 inches from the operating unit and insert the Unit Check Valve in line (Black end toward the operating unit).

Fig 13.2



NO VACUUM BOOSTER ON TOWED VEHICLE

Non-Vacuum Brakes (Hydro-boost)

Locate the Hydro-boost Kit in the Installation Kit.

Insert the cone shaped seal into the Venturi exhaust port and tighten the acorn nut.

Fig. 13.3



Cut a two inch length from the provided vacuum hose. Insert the plug in one end and slide the other end over the vacuum port of the Air Force One Unit.

Fig. 13.4



Step 6: Mount the Cylinder

Special attention must be given to vehicles with adjustable pedals. Check for proper clearance in all positions. When adjusting the cable, be sure that the pedals are positioned closest to the driver's seat. This will allow normal operation of the adjustable pedals. Be sure to return the pedals closest to the driver's seat when preparing to tow, or the braking system will not function properly. As an option, the pedals may be moved to the desired position and disabled. **Do not depend on the fact that "no one moves them."**

1. Find a location on the brake arm that will position the cylinder as low as possible but as high as necessary not to interfere with normal driving. The higher the cylinder is mounted, the less effective it is. Note: Some vehicles are equipped with a "hush panel" under the dash which may need to be removed or modified. The cylinder should be about 1-2" above the driver's foot location while operating the vehicle. Remember, during normal operation the brake pedal is depressed with the ball of the foot.
2. Position the actuator. Place the actuator on the brake arm, slide the backplate over the bolts, and position the actuator so that the brake arm is in the middle of the bracket. Loosely thread the nuts on the bolts. The actuator should be mounted so that when the brake pedal is depressed about two inches the actuator is perpendicular to the fire wall. This equates to about 1 inch above straight in line (See Fig 14.1). Now tighten the nuts finger tight to temporarily hold the actuator in place. Note: Be sure to cut away any sound deadening material before attempting to mount the clamp.

ATTENTION INSTALLERS

*Cable breakage can only occur if there is an improper angle or if the cable is overtightened in the anchor. Review this step carefully after the cylinder is mounted to ensure proper installation. Ensure cable anchor is installed within 1" variance of a straight line to the cylinder.

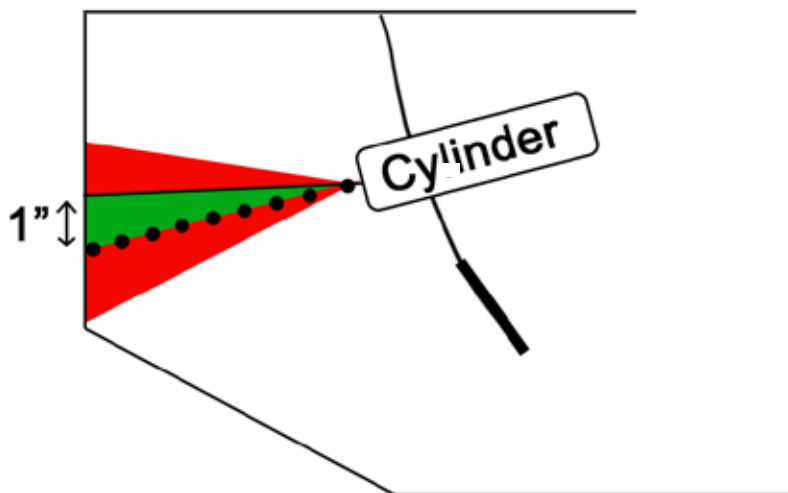

Fig 14.1

3. Mark the anchor location on the fire wall. Thread the cable through the anchor and position the anchor on the fire wall so that the cable has a direct line to the actuator throughout the swing of the brake arm. Once the location is determined go ahead and remove the slack in the cable leaving about 1/4" - 1/2" of slack. Hold the cable in place, thread the cable around and through the anchor causing it to be "double looped" (Fig 14.2), and tighten the set screw to **15 inch-pounds**. (About 1 full turn after contact). The amount of slack has no effect on the amount of pressure or proportionality of the systems. It only reduces the available stroke of the actuator. Excessive slack will result in premature wear of the actuator cable. Important: The set screw has teeth designed to grip the cable preventing slippage. Depending on the wrench used it is possible to over-tighten and damage or even sever the cable. Bear in mind that with a 5" wrench only 3 lbs of force is required, with a 7.5" wrench only 2 lbs., etc.

Fig 14.2



Fig 14.2.1

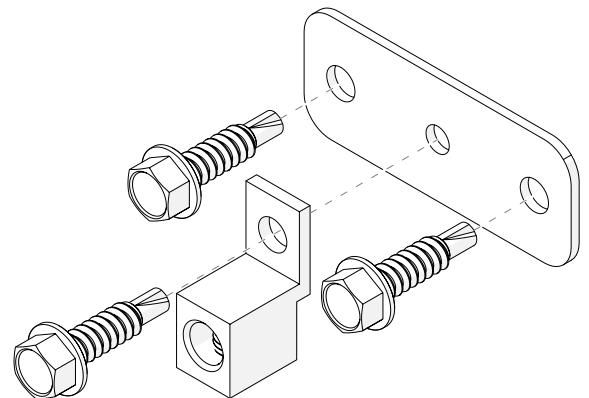

4. Using the provided self-drilling screw mount the anchor to the fire wall. Visually verify from the engine side of the fire wall that the proposed location is acceptable for the self-drilling screw. Often, a small pilot hole can be helpful in verifying the location. Mount the clamp. If the fire wall is found to be too thin to properly secure the anchor, a nut and bolt may be needed to firmly secure the anchor or use the included reinforcement plate and self-drilling screws as shown in figure 14.2.1.

5. Secure the Actuator. Verify that there is still only 1/4" - 1/2" of slack in the cable. It may be necessary to move the actuator forward or backward if the amount of slack changed during fitment. Tighten the bolts in a cross pattern until the backplate begins to bend around the brake arm. This will "lock" the nuts and keep them from loosening Figures 14.3 & 14.4 & 14.5 on the following page.

6. Route a length of 1/4" DOT air line from the cylinder to the Air Force One Unit and connect it to the pushlock connector labeled "Air Out".

Fig 14.3



Fig 14.4



Fig 14.5



*Cable breakage can only occur if there is an improper angle or if the cable is overtightened in the anchor. Review this step carefully after the cylinder is mounted to ensure proper installation. The actuator cable is a stranded steel aviation cable with a tensile strength of 460lbs. The actuator is mechanically unable to break the cable by force.

Step 7: Install the Monitor Light

Note: The reed switch attached to the actuator will power the LED. The brake switch will no longer be providing the signal for the monitor Light.

Note: Exercise caution when installing the reed switch. If the reed switch arcs to ground, it will either no longer work or cause the LED to stay illuminated at all times.

The following instructions are written with a labor-saving installation method of the monitor light. A wireless radio set is also available (PN 9599005). Contact the Demco Help Line for specifics if needed.



* All parts needed for this step are located in the "Coach Notification Bag"

1. Decide on a location for the LED Strip. The provided LED strip is extremely bright and can be placed in any location on the towed vehicle that is viewable in the rear camera of the coach. Many have found that the back side of the rear view mirror provides a good backdrop for the LED and is easily viewable in the coach's rear camera. The following steps are written with this in mind.
2. Using the provided double sided tape, attach the LED to the rear view mirror of the towed vehicle.
Note: During tow it may be helpful to angle the rear view mirror toward the rear camera of the coach.
3. Conceal the wire by routing it along the top of the windshield and down the side of the A-pillar on the driver's side of the towed vehicle. The A-pillar can be removed if needed, but exercise caution as some models have side curtain air bags. Most A-pillar covers are secured with 1-2 screws (in the handle area) and hidden pop connectors. Remove the screws and gently pull the cover away from the pillar. Note: It may be necessary to extend the wires of the LED.
4. Attach the red wire of the LED to the black wire of the reed switch located on the actuator.
5. Using the provided 3-Way Crimp Connector, attach the black wire of the LED and the blue wire of the reed switch to a suitable frame ground. Note: If there is not a suitable ground easily accessible under the dash, the ground wires can be routed through the fire wall with the airline and the reed switch's brown wire in Step 4 of this Installation Manual
6. Route the brown wire from the Reed Switch through the fire wall and connect it to the 3-way crimp connector as stated in Step 3.
7. Slide the reed switch into the bracket, make sure the switch is fully seated into the bracket. Tighten the set screw at the end of the reed switch (it is important not to overtighten this set screw).
8. Insert the 10 amp fuse into the fuse holder.

Step 8: Verify Cylinder Switch Position

The switch on the actuator is a Reed Switch. It detects the presence of a magnet on the inner part of the actuator. When the magnet is near the switch the light is off. When the magnet moves away (i.e. activation) the light turns on.

Note: The switch must be connected to power and ground prior to checking the position. The switch is preset from the factory so in most cases adjustment is not necessary.

1. Press the brake pedal to create slack in the cable.
2. With the other hand pull the outer part of the actuator back (this will pull slack from the cable.)
3. Watch the switch to see when the integrated LED illuminates. It should illuminate at 0.010" of travel or just under an 1/8".
4. To make the LED come on sooner, slide the switch and bracket back toward the airline. To make the LED come on later, slide the switch and bracket away from the airline.



AIR FORCE ONE INSTALLATION

1. Connect the air hose between the car. Start the coach and allow the air to build completely. It will take longer than usual, as the tanks are completely empty.
2. Apply the coach brake about $\frac{1}{4}$ of the way down. Have an assistant verify the brakes are being applied in the towed vehicle, and verify the notification light is on and visible from the backup camera in the coach. If not, and the brakes are applied in the towed vehicle, verify the notification light connections.
3. Apply increasingly more pressure to about $\frac{1}{2}$ of the way down. Verify that the brakes are applied in the towed vehicle by an increasing amount.
4. While in a safe location, release the parking brake without depressing the service brake. Verify the towed brake is not active. If it is, the Coach Air Connection Assembly is incorrectly configured. Call the Help Line at 800-543-3626.
5. The application of the brake in the above steps has now charged the breakaway tank. Pull the breakaway pin and verify that the brakes are applied in the towed vehicle.

Operation

The Demco Air Force One requires no adjustments or maintenance. Under all circumstances and in all towed vehicles it will always mirror the brake pedal of the coach. When preparing to tow, connect the Air Force One jumper, breakaway cable, and the notification light. Start the coach and allow it to air-up completely. After the coach's tanks are at full pressure, depress the Coach's brake pedal completely and hold it for at least three seconds. This will do two things: allow you to verify that the unit is connected properly and fully charge the breakaway-reserve tank. This completes the setup and pretest of the Air Force One system.

Coach

Jumper

Towed Vehicle

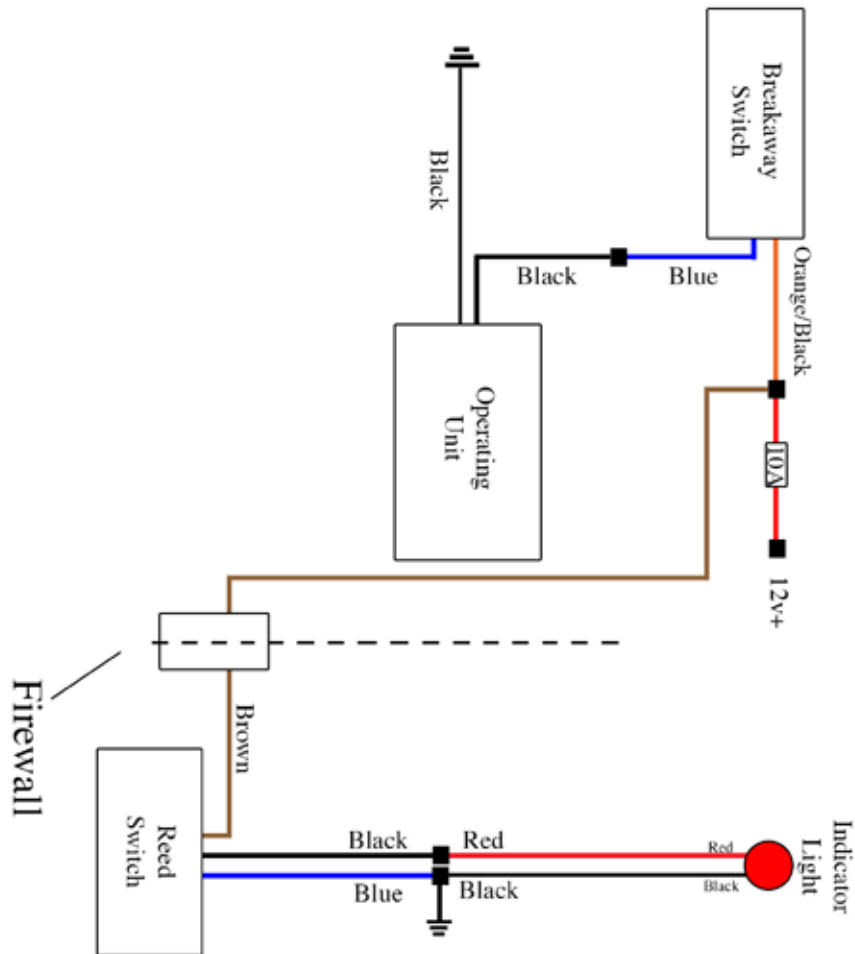

Coach

Jumper

Towed Vehicle

*This diagram is for general reference only and not intended to be a substitute for the written instructions.
Port and hose locations may differ.*

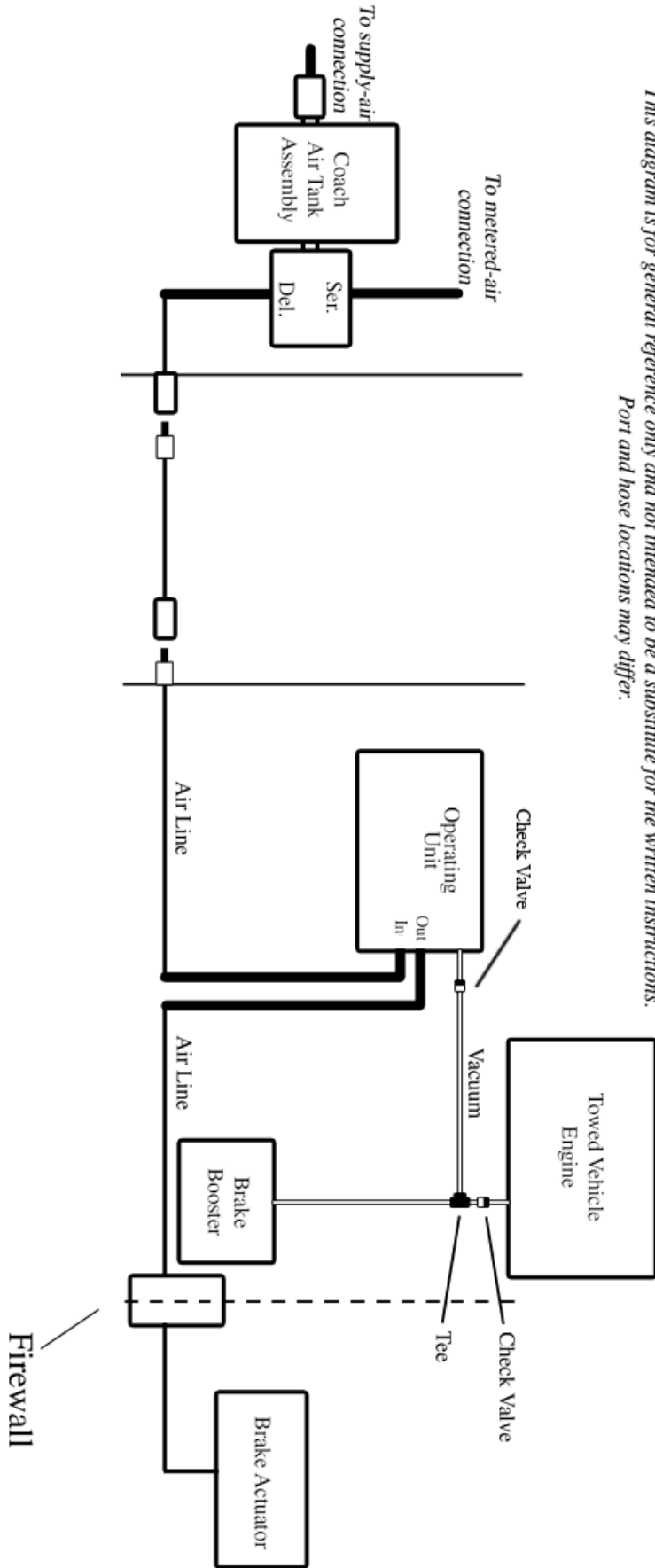

WARRANTY INFORMATION

Limited Five (5) Year Warranty

We are confident that our product will perform well and therefore warrant the original purchaser, that the new product will be free from mechanical and electrical defects in material and workmanship during the warranty period. The Warranty period begins on the original purchase date. The warranty is for current production models and the original purchaser only. Demco does not warrant any part of the installation nor failure related to improper installation.

The Warranty Period

1st Year

If, during the first 12 months of the warranty period, your Demco product should be found defective, Demco will repair or replace the product at its discretion. Demco will refund to the original purchaser freight charges incurred in returning the product to the factory during this portion of the warranty period. (This does not include repackaging charges incurred to a third party). All warranty shipping & freight charges are for normal delivery, expedited freight charges are not included. Demco may choose, at its sole discretion, to allow usage of other new parts for the purpose of warranty repair. Such approval requires prior authorization and is subject to the return authorization policy.

Labor pertaining to warranty repair will be covered with prior approval from Demco and is subject to the return authorization policy. Warranty performed prior to approval will be reviewed and assessed by Demco on a case by case basis.

2nd - 3rd Year

If, during the 2nd through the 3rd year of the warranty period, the Demco product should be found defective, Demco will, upon receipt of post prepaid product, repair or replace the product at its discretion. The Demco product will be returned via standard delivery free of charge.

Outside labor pertaining to warranty repair is not covered.

4th - 5th Year Extended Warranty

In order to receive 4th and 5th years of warranty, the Demco product must be registered within 30 days of purchase. Consideration for special cases may be addressed on a case-by-case basis at Demco's discretion. If, during the 4th and 5th years of warranty period, the Demco product should be found defective, Demco will, upon receipt of post prepaid product, repair or replace the product at its discretion. Demco reserves the right to charge for labor on required repairs of the Demco product depending on condition of the product received. Customer will be responsible for return shipping during this portion of the warranty period.

Outside labor pertaining to warranty repair is not covered.

What is Not Covered

Our warranty for your product will not cover damage resulting from set-up for towing, installation, neglect or misuse, use contrary to operating instructions, charges associated with removal/replacement of components, distortion and/or damage caused by either or heat, or disassembly, repair, or alteration by any person other than an authorized service center. Any implied warranty of merchantability or fitness for a particular purpose of your product is limited to the duration of this written warranty. We shall not be liable for any incidental or consequential damages for breach of any express or implied warranty.

Your State Laws

Some states do not allow limitation on how long an implied warranty lasts or the exclusion or limitations of incidental or consequential damages, so the above may not apply to you. This warranty gives you specific legal rights, and you may also have other rights, which vary from state to state.

DEMCO

4010 320th St., Boyden, IA. 51234

Phone: (712) 725-2311

Fax: (712) 725-2380

Toll Free: 1-800-54DEMCO (1-800-543-3626)

**Demco warranty policies, operator manuals, and product registration
can be found online:**

www.demco-products.com

