

# **TORKLIFT** **INTERNATIONAL**

**OVER 35 YEARS OF INNOVATION, QUALITY, SAFETY.**

**IMPORTANT OWNER-OPERATOR INSTALLATION INSTRUCTIONS**

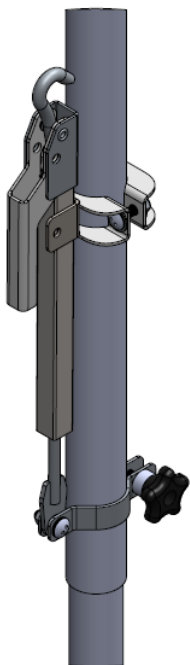



**Part # A7006**





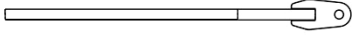
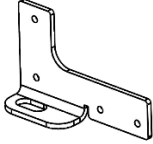
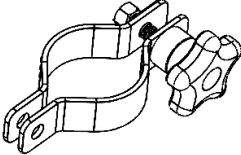
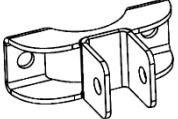
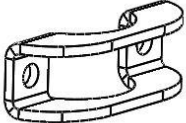

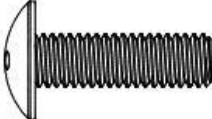

REVISED version 7 DK BY: 11/23/2015  
**TECH SUPPORT (800) 246-8132**

**AFTER INSTALL, PLEASE GIVE  
THIS BOOKLET TO YOUR CUSTOMER**

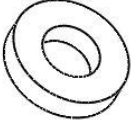
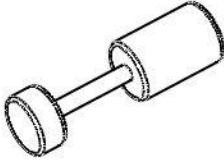
## Parts List

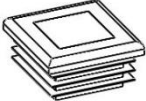
Wobble Stopper Body		<b>2</b>
Wobble Stopper Shaft		<b>2</b>
Camper Bracket		<b>2</b>
Lower Bracket Assembly		<b>2</b>
Upper Bracket		<b>2</b>
Upper Bracket Clamp		<b>2</b>
3/8" SAE Flat Washer		<b>16</b>
3/8"-16 SS Nylock Nut		<b>6</b>
3/8"-16 x 1-1/4" SS Spanner Bolt		<b>6</b>
Spanner Bolt Driver		<b>1</b>

## Parts List Continued

1/2"-13 SS Thin Nylock Nut		2
1/2" Flat O-ring		2
FastGun Lock		2
1/2"-13 Zinc Square Nut		2
Square Nylon Cap		2
Velcro Strap		2
#10 x 1-1/4" SS Security Screws		8
Hex Pin Driver for #10 Security Screws		1
#10 x 1-1/4" SS Phillips Pan Head Tap Screw		8

# Installation

## Step 1:

Begin by Opening the handle on the **Wobble Stopper Body** and Slide the **Wobble Stopper Shaft** up into the **Wobble Stopper Body** until it protrudes from the top of the tube. Inserting a **1/2"-13 Zinc Square Nut** into the top of the tube and thread it onto the **Wobble Stopper Shaft**. Install one **1/2" Flat O-Ring** followed by one **1/2"-13 SS Thin Nylock Nut** onto the top of the **Wobble Stopper Shaft**. The handle can be used to hold the **1/2"-13 SS Thin Nylock Nut** in place while the **Wobble Stopper Shaft** is threaded through the nut.

Seat the **Square Nylon Cap** into the top of the **Wobble Stopper Body**. See Figure 1.1 below.

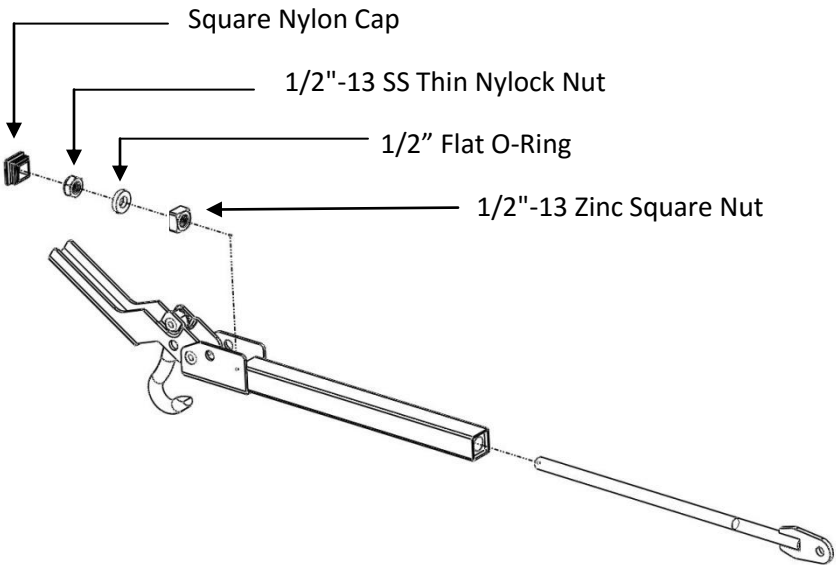
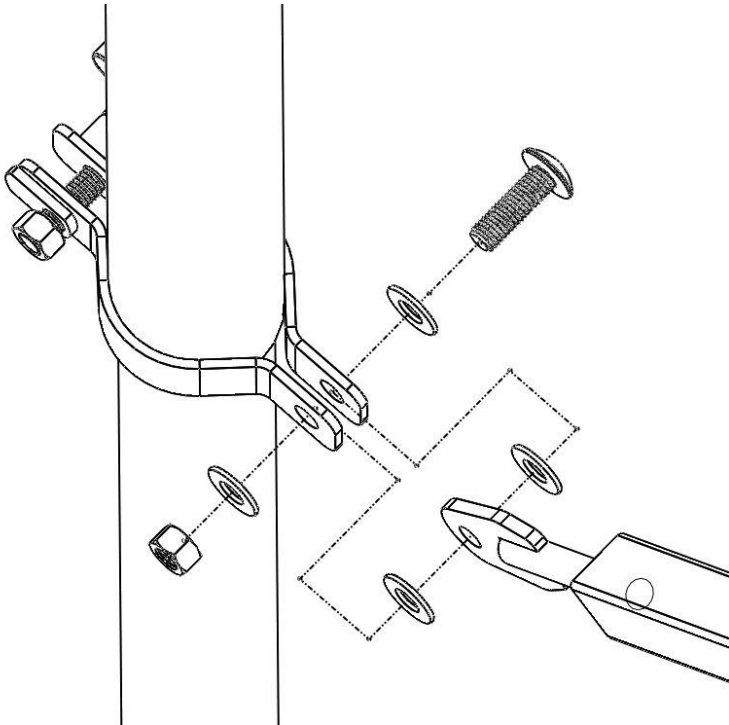

Figure 1.1

**Step 2:**

Locate the **Lower Bracket Assembly** and turn the knob until the two halves of the bracket are as far apart as possible. Twist the two halves of the bracket so that they are 90 degrees to one another, and install onto the camper jack. Use one **3/8"-16 x 1-1/4" SS Spanner Bolt**, Four **3/8" SS USS Washers** and one **3/8"-16 SS Nylock Nut** to assemble the Wobble Stopper to the **Lower Bracket Assembly** as shown in **Figure 2.1**. Leave the bolt loose enough to allow the Wobble Stopper to rotate in the **Lower Bracket Assembly**.



**Figure 2.1**

### Step 3:

Use the knob to tighten the **Lower Bracket Assembly** to the Camper Jack. The bottom of the **Lower Bracket Assembly** should be at approximately the same height as the bottom of the camper.

### Step 4:

Using one **3/8"-16 x 1-1/4" SS Spanner Bolt**, two **3/8" SS USS Flat Washers** and one **3/8"-16 SS Nylock Nut** per side, assemble the **Upper Bracket** and **Upper Bracket Clamp** to the jack as shown in **Figure 4.1**. The **Upper Bracket** should face away from the camper for maximum clearance, but can also be mounted at any position 360 degrees around the jack. The top of the **Upper Bracket** should be located approximately 15" above the bottom of the **Lower Bracket Assembly**. Torque the bolts to 15 ft-lbs.

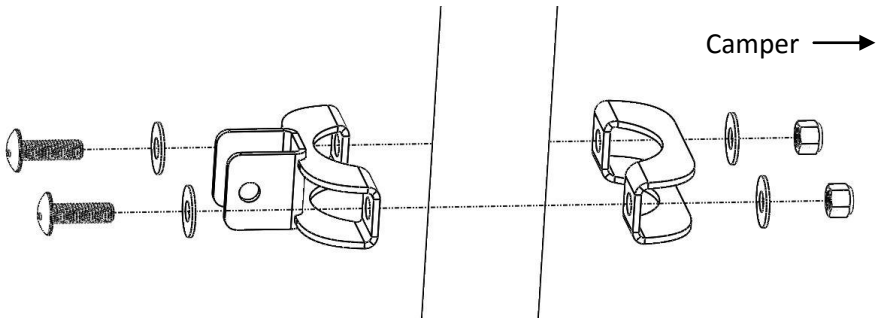

**Figure 4.1**

### Step 5:

Install the supplied **Velcro Strap** around the camper jack midway between the **Upper Bracket** and **Lower Bracket Assembly**.

### Step 6:

Place the **Camper Bracket** up against the camper in the lower front corner as shown in **Figure 6.1**. Use a stud finder or contact your local RV dealer or manufacture to ensure the holes in the **Camper Bracket** align with studs in the camper. Use the butyl tape on the backside of the **Camper Bracket** to temporarily mount it to the camper. Install four **#10 x 1-1/4" SS Security Screws** through the **Camper Bracket** and into the studs of the camper using the supplied **Hex Pin Driver**. Alternately, four supplied **#10 x 1-1/4" SS Phillips Pan Head Tap Screws** may be substituted for the **Security Screws** (Figure 6.1).

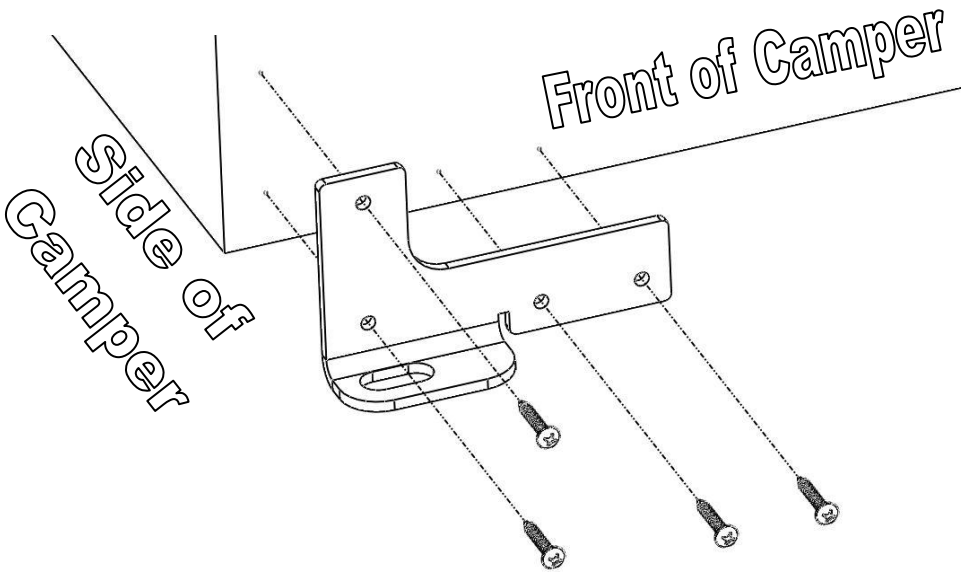

Figure 6.1

### Step 7:

Repeat Steps 1-6 on the opposite side of the camper.

# Operation

## Step A:

With the Camper unloaded from the truck and resting on all four jacks, loosen the **Nylon Knob** and rotate the Wobble Stopper assembly so that it is facing inside towards the **Camper Bracket**. Retighten the **Nylon Knob** and, with the handle open, hook the end of the wobble stopper into the **Camper Bracket**. When hooked up, the Wobble Stopper should be parallel to the ground. If it is not, it may be possible to disconnect the wobble stopper without removing the lock.

## Step B:

Adjust the length of the Wobble Stopper by rotating the **Wobble Stopper Body** around the **Wobble Stopper Shaft**. Adjust the length so that there is a small amount of resistance in the handle just before it is closed. The Wobble Stopper should be tightened enough to have some tension between the jack and **camper bracket**, but not enough to twist the jack. Adjust both sides evenly. Lock the Handles in place with the **FastGun Locks** to secure the camper from theft. See **Figure B.1**

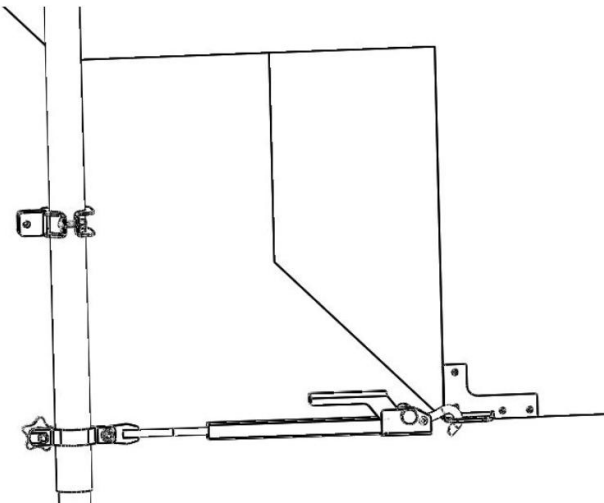
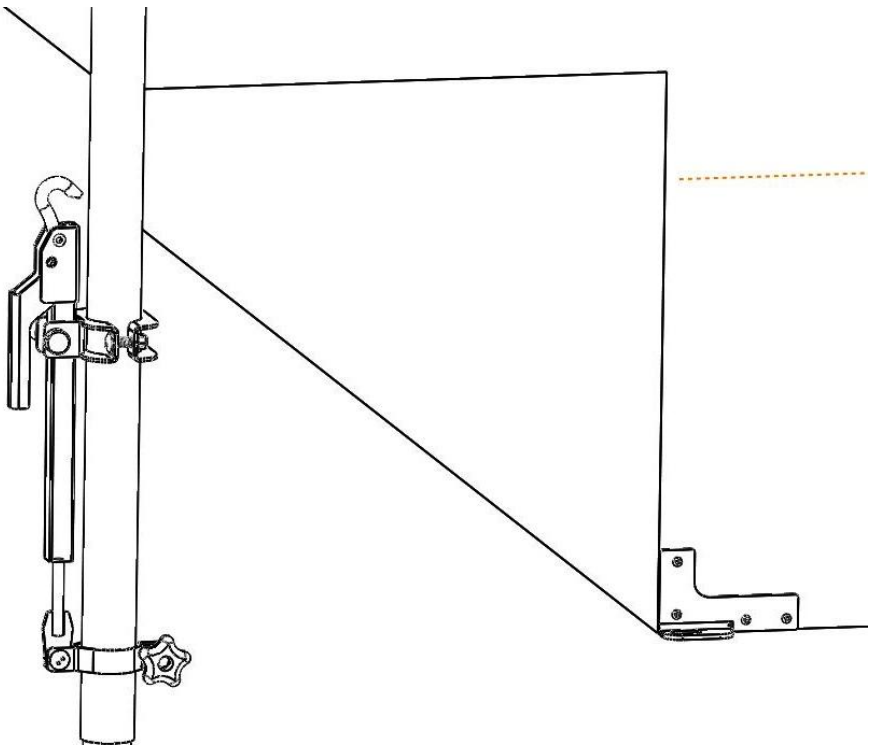

Figure B.1

**Step C:**

To disconnect and store the Wobble Stoppers, Release the **FastGun Locks**, raise the handles, and loosen the knobs on the **Lower Bracket Assemblies**. Rotate the Wobble Stopper to the outside of the jack and swing the Wobble Stopper up until the **Wobble Stopper Body** rests into the **Upper Bracket**. Pin the included **FastGun Lock** through the Upper Bracket to secure the Wobble Stopper in place. Wrap the **Velcro Strap** around the **Wobble Stopper Body** and back onto itself to prevent the Wobble Stopper from Rattling. See **Figure C.1**



**Figure C.1**

## **RECOMMENDED TRUCK CAMPER INSTALLATION INSTRUCTIONS**

When securing any heavy load (especially a camper) in your truck bed, your front tie down points should pull the load forward as much as possible. Some camper anchor points may differ with different manufacturers, as well as the camper jack mounting locations. Your Torklift tie down inserts have offset triangular brackets to increase the angle of pull. These are designed to be used in the front facing forward, and the rear facing rearward but can be used in either front or rear. These recommendations are to be considered and followed as a basic rule of thumb. Obviously there will be some applications where this may not be possible. At a minimum, if opposite pull of both front and rear Tiedowns cannot be achieved for whatever reason, you should have at least a forward pull at the front or rear location. If your camper does not come with Rubber Bumpers on the front lower portion of the camper, installing Rubber Bumpers (Torklift has Rubber Bumpers available Part A7001) or using a block of wood such as a 2 x 4 in the bed, will prevent the camper from damaging the front bulk head of the truck bed. Minor movement (or settling) can occur in some incidental harsh driving conditions (on or off road). A rubber bed mat is not a requirement to maintain the lifetime warranty on a Torklift system, but a strong recommendation simply as a safety precaution to protect the truck bed, the bottom of the camper and to give the camper additional support.

**TORKLIFT DOES NOT RECOMMEND:** Installing your truck camper in your truck on top of a drop in plastic bed liner!!! The drop in plastic bed liners can slide on top of the truck bed surface, and the camper can slide on top of the slick surface of the bed liner. The liner can also act as a spring causing a trampoline effect increasing vertical truck camper movement, independent of the vehicle, possibly resulting in truck bed, and camper damage!

## **INSTRUCTIONS FOR FINISH MAINTENANCE OF TORKLIFT PRODUCTS**

### **POWDER COATED STEEL:**

To keep your Torklift products looking good follow these guidelines. All steel powder coated Torklift products are sandblasted for maximum adhesion and use a high quality industrial urethane based powder coat. Due to the extreme, harsh, undercar environment that your Torklift products live in, (consistently sprayed with corrosive road chemicals such as salt, and road debris), Torklift does not warrant the powder coated finish.

To minimize corrosion from these factors on powder coated steel products, Torklift recommends regularly cleaning and inspecting the powder coated surface and touching up any affected areas with an enamel or urethane based aerosol paint product. If there are any areas of surface rust, there are also aerosol spray rust converters available on the market that can be used as a preparation to touch-up paint application. These finish maintenance products are available at any automotive parts supplier.

### **POLISHED STAINLESS STEEL :**

TorkLift utilizes quality grade 304 stainless steel in our stainless steel polished products. 304 stainless steel is well known for its anti-corrosive properties. However, in some environments such as coastal regions or when coming in contact with some road chemicals, corrosion may occur. For a quick clean simply use WD40 and a cloth rag. We also recommend occasional polishing of our polished stainless products to maintain their attractive finish. Use an approved stainless steel chrome or aluminum mag wheel polish cleaning product which can be purchased from any automotive parts supplier.



## **Frame Mounted Tie Downs**

Leading the camper tie down industry in strength, quality, advanced design and installation. TorkLift TRUE frame mounted tie downs are far superior to all tie down systems available.

The TorkLift system is unique in its design and is patented. Four independent tie down points (with no belly or crossbar) working much like your receiver type trailer hitch as the inserts are removable allowing the system to be virtually undetectable when not in use. They are designed for each make and model to fit tight to the frame so as not to compromise ground clearance. Torklift tie downs are not universal 'one size fits all' therefore all the problems with correct fit for each particular application have been eliminated.

**VISIT [WWW.TORKLIFT.COM](http://WWW.TORKLIFT.COM) FOR MORE INFORMATION**

## **Original SuperHitch & SuperHitch Magnum**

High strength extended hitch system engineered for safely towing all types of trailers behind your truck and camper. With a max towing capacity of 14,000 lbs. with an extension\* , (17,000 lbs. to 20,000 lbs. without\*) the Original SuperHitch and Superhitch Magnum are rated the strongest in the industry.



**CONTACT YOUR LOCAL DEALER FOR MORE DETAILS**

# **Torklift International Limited Lifetime Warranty Information**

1901 Fryar Ave Sumner, WA 98390

Torklift will require proof of purchase to register, with pictures of any defective product before issuing a replacement. Torklift will not register any product without proof of purchase, which can be faxed, scanned, emailed, or mailed to the information provided below.

Torklift warrants it's hitches, custom hitch receivers, frame mounted tie downs, turnbuckles, and accessories (excluding wire harnesses which carry a 90 day warranty) from date of purchase against defects in material and workmanship under normal use and service for the ownership life of the original consumer purchaser. **ALL COMMERCIAL APPLICATIONS ARE WARRANTED FOR A PERIOD OF 90 DAYS FROM THE DATE OF**

**INSTALLATION/SERVICE. Torklift will replace FREE OF CHARGE any part which proves defective in material or workmanship when presented to Torklift, TRANSPORTATION CHARGES PREPAID by purchaser, at the address above. THIS WARRANTY IS LIMITED TO DEFECTIVE PARTS REPLACEMENT ONLY. LABOR CHARGES AND/OR DAMAGE INCURRED IN INSTALLATION OR REPLACEMENT, AS WELL AS INCIDENTAL AND CONSEQUENTIAL DAMAGES**

**CONNECTED THEREWITH ARE EXCLUDED.** This warranty does not include the finish or paint on our products. Rusting, cracking or peeling of the finish is also excluded. Some states do not allow the exclusion or limitation of incidental or consequential damages, so the above limitation or exclusion may not apply to you. Any damage to Torklift products as a result of misuse, abuse, neglect, accident, improper installation or any use violative of

**instructions furnished by Torklift or WHEN USED IN ANY COMMERCIAL APPLICATION WILL VOID THE WARRANTY.**

This warranty gives you specific legal rights, and you may also have rights which vary from state to state. With warranty service, you may be able to go to a small claims court, a state court or a federal district court.



## ***INTERNATIONAL***

**1901 Fryar Avenue Sumner WA, 98390  
Phone (800) 246-8132 Fax (253) 854-8003**

**Or visit our website: [www.TorkLift.com](http://www.TorkLift.com)**

Dear Valued Customer,

Thank you for making TorkLift your choice for truck, camper packages and accessories for your vehicle. By choosing TorkLift products, you have chosen a company that has been serving the RV industry for nearly 40 years and whose name has become synonymous with strength, quality and advanced design and installation.

Please take a few moments of your time to complete the Product Registration Warranty Card on the next page. When registering your newly purchased TorkLift products, you can be assured that your contact information is secure and that you and your product are getting the attention and respect that you deserve.

Thank you again for choosing TorkLift quality products.

**Register for your lifetime warranty and receive a free  
Torklift  
International gift.**

To Fax: Send copies of the questionnaire, warranty card and receipt to  
253-854-8003

To E-mail: Send copies of the questionnaire, warranty card and receipt to  
[warranty@torklift.com](mailto:warranty@torklift.com)

To Mail: Send to Torklift International 322 N Railroad Ave. Kent, WA 98032



## OFFICIAL WARRANTY REGISTRATION CARD

PLEASE FILL OUT THIS FORM COMPLETELY AND RETURN TO TORKLIFT WITHIN  
30 DAYS OF PURCHASE ACCOMPANIED BY A COPY OF YOUR ORIGINAL RECEIPT

### 1. PART(S) PURCHASED

TODAY'S DATE: \_\_\_\_\_

PART#: \_\_\_\_\_ PART#: \_\_\_\_\_

PART#: \_\_\_\_\_ PART#: \_\_\_\_\_

PART#: \_\_\_\_\_ PART#: \_\_\_\_\_

### 2. PURCHASER INFORMATION

NAME: \_\_\_\_\_

ADDRESS: \_\_\_\_\_

CITY: \_\_\_\_\_ STATE: \_\_\_\_\_ ZIP / POSTAL CODE: \_\_\_\_\_

PHONE: ( ) - \_\_\_\_\_ EMAIL: \_\_\_\_\_

### 3. TRUCK INFORMATION

YEAR: \_\_\_\_\_ MAKE: \_\_\_\_\_

MODEL: \_\_\_\_\_ BED LENGTH: \_\_\_\_\_

### 4. CAMPER INFORMATION

YEAR: \_\_\_\_\_ MAKE: \_\_\_\_\_ MODEL: \_\_\_\_\_

### 5. DEALER INFORMATION

PURCHASED FROM: \_\_\_\_\_

ADDRESS: \_\_\_\_\_

CITY: \_\_\_\_\_ STATE: \_\_\_\_\_ ZIP / POSTAL: \_\_\_\_\_

INSTALLED BY: OWNER ABOVE DEALER ANOTHER DEALER

IF ANOTHER DEALER, WHO: \_\_\_\_\_