



TORKLIFT

INTERNATIONAL

OVER 35 YEARS OF INNOVATION, QUALITY, SAFETY.
IMPORTANT OWNER-OPERATOR INSTALLATION INSTRUCTIONS

A7009

TIE DOWN CAPPING KIT

UNIVERSAL

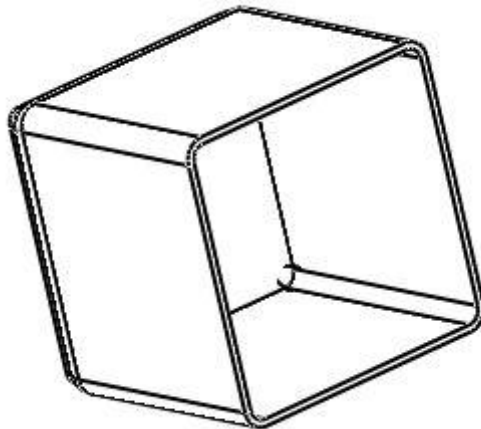

REVISED vers4 BY: DK 11/23/15

TECH SUPPORT (800) 246-8132

**AFTER INSTALL, PLEASE GIVE
THIS BOOKLET TO YOUR CUSTOMER**

UNIVERSAL CAPPING KIT INVENTORY

4 - 1-3/4" X 1-3/4" X 2" FOAM BACKING PLUG

4 - 2" X 2" X 1-1/2" RECEIVER CAP

INSTALLATION INSTRUCTIONS:

STEP 1

INSERT ONE 1-3/4" X 1-3/4" X 2" FOAM BACKING PLUG INTO THE BACK OF THE TIE DOWN RECEIVER OPENING. IF THE BACK OF THE RECEIVER IS INACCESSIBLE, INSERT THE FOAM BACKING PLUG IN THE FRONT OF THE TIE DOWN RECEIVER AND PRESS IT BACK WITH THE TIE DOWN INSERT.

SEE PHOTO A

STEP 2

INSERT ONE 2" X 2" X 1-1/2" RECEIVER CAP OVER THE END OF THE TIE-DOWN RECEIVER. **SEE PHOTO B** (IF THE 2" X 2" X 1-1/2" RECEIVER CAP DOES NOT FIT DOWN THE RECEIVER, YOU WILL NEED TO NOTCH IT OUT USING A BOX KNIFE OR SIMILAR) **SEE PHOTO C**

STEP 3

REPEAT ON THE OTHER TIE DOWN

PHOTO A

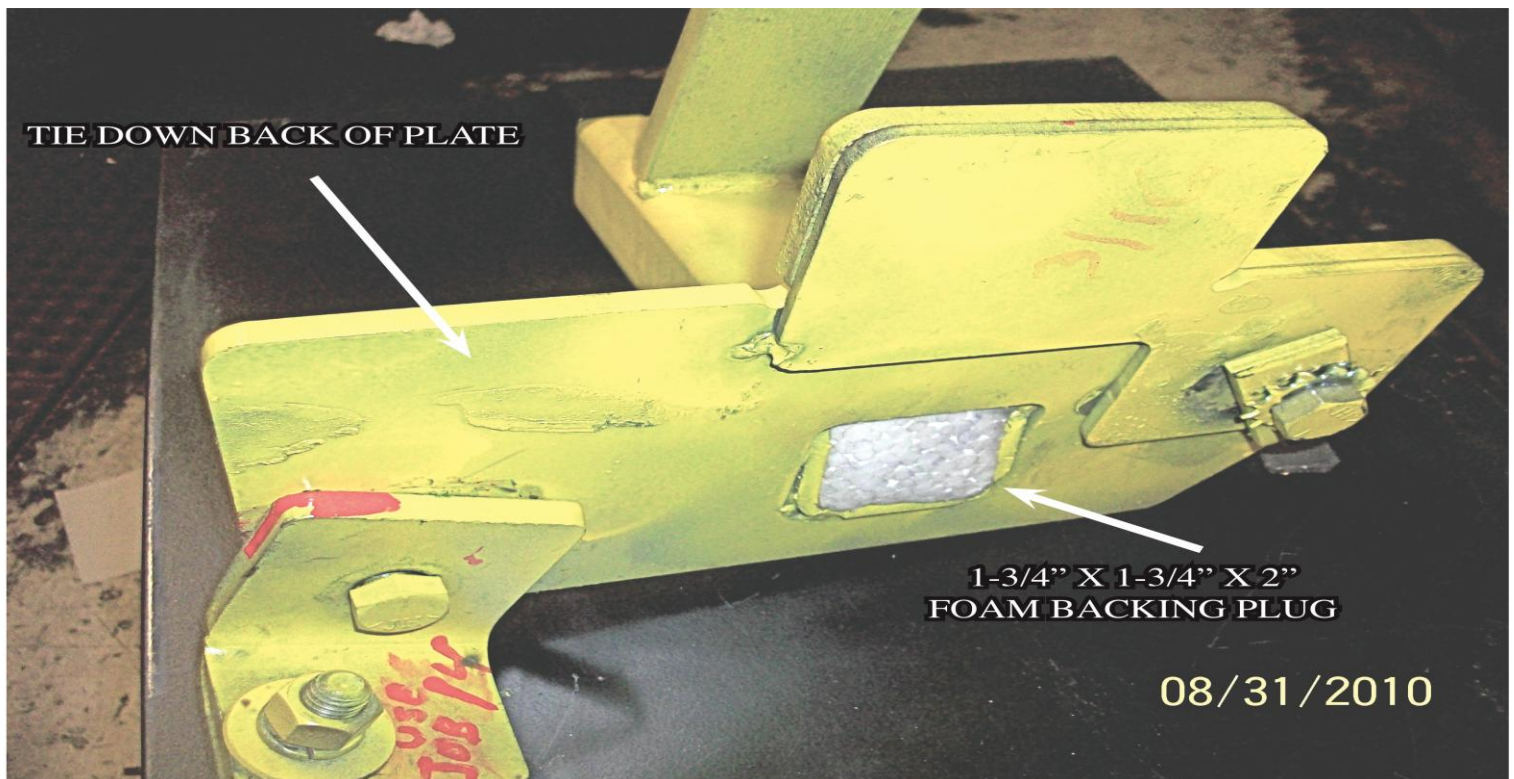

PHOTO B

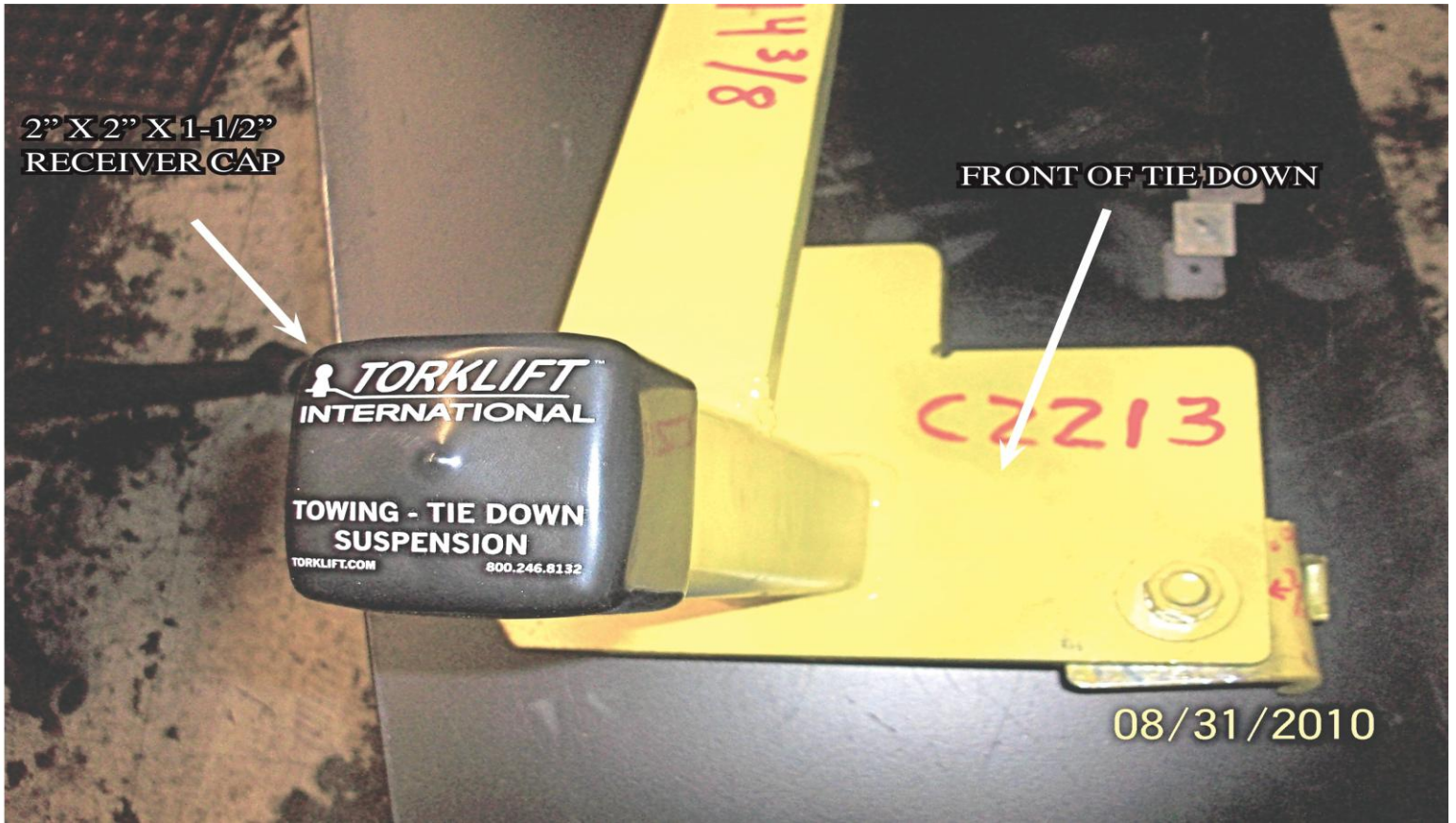
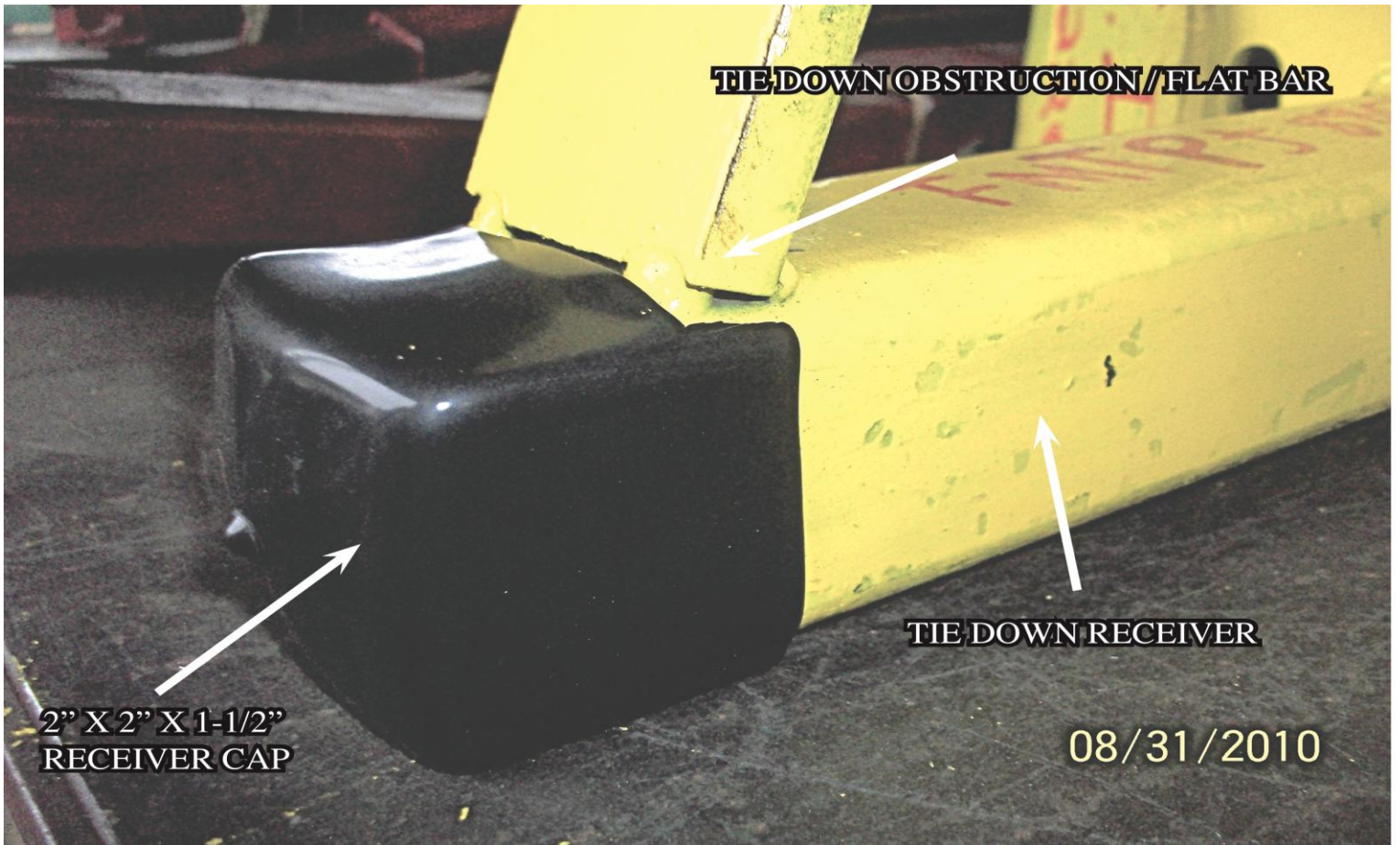

PHOTO C



Torklift International Limited Lifetime Warranty Information

322 N Railroad Ave. Kent, WA 98032

Torklift will require proof of purchase to register, with pictures of any defective product before issuing a replacement. Torklift will not register any product without proof of purchase, which can be faxed, scanned, emailed, or mailed to the information provided below. Torklift warrants its hitches, custom hitch receivers, frame mounted tie downs, turnbuckles, and accessories (excluding wire harnesses which carry a 90 day warranty) from date of purchase against defects in material and workmanship under normal use and service for the ownership life of the original consumer purchaser. ALL COMMERCIAL APPLICATIONS ARE WARRANTED FOR A PERIOD OF 90 DAYS FROM THE DATE OF INSTALLATION/SERVICE. Torklift will replace FREE OF CHARGE any part, which proves defective in material or workmanship when presented to Torklift, TRANSPORTATION CHARGES PREPAID by purchaser, at the address above. THIS WARRANTY IS LIMITED TO DEFECTIVE PARTS REPLACEMENT ONLY. LABOR CHARGES AND/OR DAMAGE INCURRED IN INSTALLATION OR REPLACEMENT, AS WELL AS INCIDENTAL AND CONSEQUENTIAL DAMAGES CONNECTED THEREWITH ARE EXCLUDED. This warranty does not include the finish or paint on our products. Rusting, cracking or peeling of the finish is also excluded. Some states do not allow the exclusion or limitation of incidental or consequential damages, so the above limitation or exclusion may not apply to you. Any damage to Torklift products as a result of misuse, abuse, neglect, accident, improper installation or any use violation of instructions furnished by Torklift or WHEN USED IN ANY COMMERCIAL APPLICATION WILL VOID THE WARRANTY. This warranty gives you specific legal rights, and you may also have rights, which vary from state to state. With warranty service, you may be able to go to a small claims court, a state court or a federal district court.



OVER 35 YEARS OF INNOVATION, QUALITY, SAFETY.

322 N Railroad Ave. Kent, WA 98032

Phone (800) 246-8132

Fax (253) 854-8003

or visit our website: www.TorkLift.com

Dear Valued Customer,

Thank you for making TorkLift your choice for truck, camper packages and accessories for your vehicle. By choosing TorkLift products, you have chosen a company that has been serving the RV industry for nearly 40 years and whose name has become synonymous with strength, quality and advanced design and installation.

Please take a few moments of your time to complete the Product Registration Warranty Card on the next page. When registering your newly purchased TorkLift products, you can be assured that your contact information is secure and that you and your product are getting the attention and respect that you deserve.

Thank you again for choosing TorkLift quality products.

Register for your lifetime warranty and receive a free Torklift International gift.

To Fax: Send copies of the questionnaire, warranty card and receipt to 253-854-8003

To E-mail: Send copies of the questionnaire, warranty card and receipt to warranty@torklift.com

To Mail: Send to Torklift International 322 N Railroad Ave. Kent, WA 98032



OVER 35 YEARS OF INNOVATION, QUALITY, SAFETY.

OFFICIAL WARRANTY REGISTRATION CARD

PLEASE FILL OUT THIS FORM COMPLETELY AND RETURN TO TORKLIFT WITHIN 30 DAYS OF PURCHASE ACCOMPANIED BY A COPY OF YOUR ORIGINAL RECEIPT

TODAY'S DATE: _____

1. PART(S) PURCHASED

PART#: _____ PART#: _____
PART#: _____ PART#: _____

2. PURCHASER INFORMATION

NAME: _____

ADDRESS: _____

CITY: _____ STATE: _____ ZIP / POSTAL CODE: _____

PHONE: (____) _____ - _____ EMAIL: _____

3. TRUCK INFORMATION

YEAR: _____ MAKE: _____

MODEL: _____ BED LENGTH: _____

4. CAMPER INFORMATION

YEAR: _____ MAKE: _____ MODEL: _____

5. DEALER INFORMATION

PURCHASED FROM: _____

ADDRESS: _____

CITY: _____ STATE: _____ ZIP / POSTAL: _____

INSTALLED BY: OWNER ABOVE DEALER ANOTHER DEALER

IF ANOTHER DEALER, WHO: _____