

GM TRUCK SUPPORT BRACKET KIT #3243

This bracket kit helps support different models of the Andersen Ultimate 5th Wheel Connection--#3220, #3220 TBX under standard models of 2015 and newer GM (GMC and Chevrolet) truck beds, but are not required for flat beds. It fastens to the frame beneath the rearward bed saver rail.

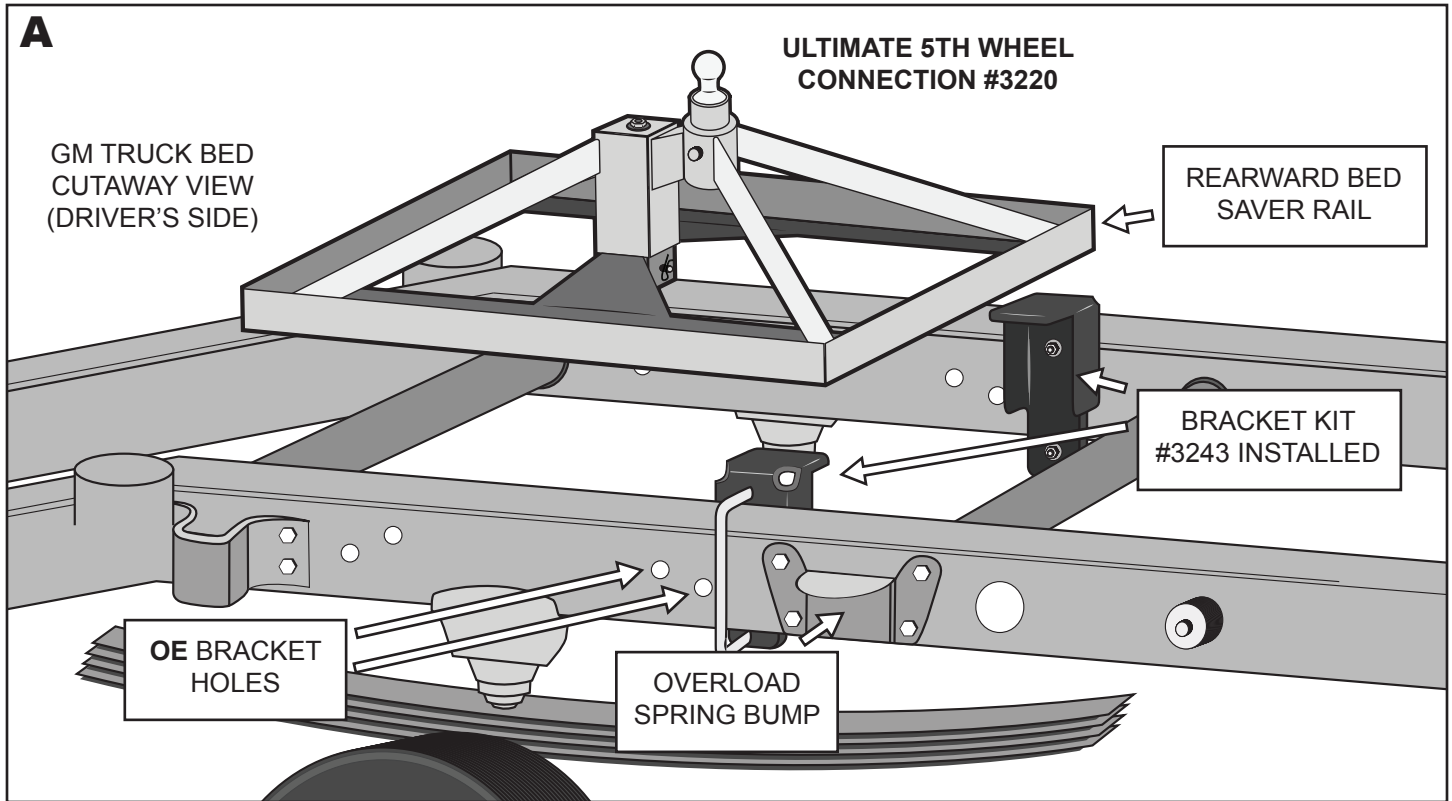

Note: The brackets are identical and can be used for either side.

To install, make sure the top of the brackets are placed below the Ultimate 5th Wheel Connection rearward bed saver rail. {fig. A}

1. Place U-bolt around the truck frame at the point between the OE bracket holes and the overload spring bump. {fig. C}. and slide on brackets inside truck frame.
2. Hand tighten (4) flange nuts on brackets {fig D}, and then torque all nuts to 75 foot pound.

