



**OVER 35 YEARS OF INNOVATION, QUALITY, SAFETY.**  
IMPORTANT OWNER-OPERATOR INSTALLATION

INSTRUCTIONS

## C1208-30

Application Fits

2011 Chevy 2500/3500 HD Long Box Crew Cab Diesel











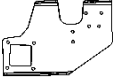











Version 13 BY: RAS 10-10-2017

TECH SUPPORT (800) 246-8132

**AFTER INSTALL, PLEASE GIVE  
THIS BOOKLET TO YOUR CUSTOMER**

# Part Inventory

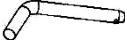
	<p style="text-align: center;"><b>30K Double Receiver Cross Tube</b></p>	<p style="text-align: center;"><b>1</b></p>
	<p style="text-align: center;"><b>Side Plates</b></p>	<p style="text-align: center;"><b>2</b></p>
	<p style="text-align: center;"><b>Angle Support Bracket</b></p>	<p style="text-align: center;"><b>2</b></p>
	<p style="text-align: center;"><b>1(2.54cm) x 2''(5cm) Plate Washer</b></p>	<p style="text-align: center;"><b>12</b></p>
	<p style="text-align: center;"><b>2''(5cm) x 2''(5cm) Center Hole Plate Washer</b></p>	<p style="text-align: center;"><b>4</b></p>
	<p style="text-align: center;"><b>1/2''(1.27cm) x 4-5/8(11.75cm)'' Chevy Galvanized Pipe</b></p>	<p style="text-align: center;"><b>2</b></p>
	<p style="text-align: center;"><b>M14 - 2.0 x 40MM 10.9 Bolt</b></p>	<p style="text-align: center;"><b>2</b></p>
	<p style="text-align: center;"><b>M12 - 1.75 X 190 MM 10.9 Bolt</b></p>	<p style="text-align: center;"><b>2</b></p>
	<p style="text-align: center;"><b>7/16'' Bolt Fisher</b></p>	<p style="text-align: center;"><b>1</b></p>
	<p style="text-align: center;"><b>1/2'' - 13 x 1-1/2'' Grade 8 Hex Bolt</b></p>	<p style="text-align: center;"><b>12</b></p>
	<p style="text-align: center;"><b>1/2'' - 13 x 2'' Grade 8 Hex Bolt</b></p>	<p style="text-align: center;"><b>8</b></p>

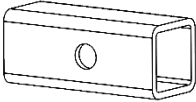
	<p><b>1/2" Washer USS Grade 5</b></p>	<p><b>12</b></p>
	<p><b>1/2" Star Washer</b></p>	<p><b>2</b></p>
	<p><b>1/2" Lock Washer High Alloy</b></p>	<p><b>16</b></p>
	<p><b>1/2" - 13 Hex Nut Grade 8</b></p>	<p><b>16</b></p>
	<p><b>7/16" - 14 x 1-3/4" Grade 8 Hex Bolt</b></p>	<p><b>2</b></p>
	<p><b>7/16" USS Flat Washer Grade 5</b></p>	<p><b>2</b></p>
	<p><b>7/16" Lock Washer High Alloy</b></p>	<p><b>2</b></p>
	<p><b>7/16" -14 Hex Nut Grade 8</b></p>	<p><b>2</b></p>
	<p><b>5/8" Pin</b></p>	<p><b>2</b></p>
	<p><b>Pin Clip</b></p>	<p><b>2</b></p>
	<p><b>Magnum Receiver Adapter</b></p>	<p><b>1</b></p>

## ***!WARNING!***

DO NOT LUBRICATE THREADS. BOLT FAILURE MAY OCCUR DUE TO OVERTIGHTENING. DO NOT DRILL ON THIS HITCH.

**NOTE THE  
DIRECTION  
OF THE  
SUPERHITCH  
SIDE PLATES  
BEFORE  
ASSEMBLY**

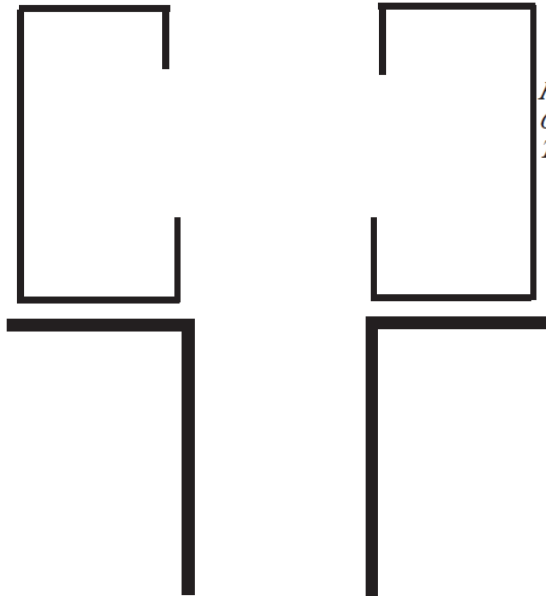

*FRAME  
OF  
TRUCK*

SUPERHITCH PLATES  
RUN-IN TOWARDS THE  
CENTER OF THE  
TRUCK FRAME IN THIS  
APPLICATION

**\*\* READ ALL INSTRUCTIONS AND FAMILIARIZE YOURSELF  
WITH THE HITCH AND FASTENERS BEFORE BEGINNING  
THE INSTALLATION \*\***

# **OVERVIEW**

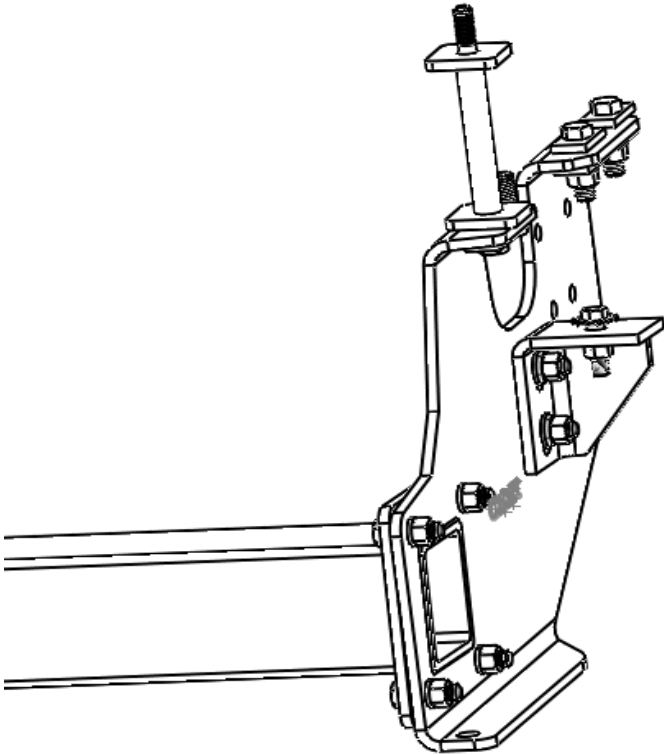

## Step 1

Remove or loosen the spare tire and locate the passenger side rear spring perch.

## Step 2

There will be three factory fasteners on the bottom side of the frame. Remove the factory hardware from **Hole 1**, **Hole 3**, and **Hole 4**. The Nut for **Hole 4** is welded to the frame, and will not be removed. See **Photo 2.1** for hole locations.

**Photo 2.1**

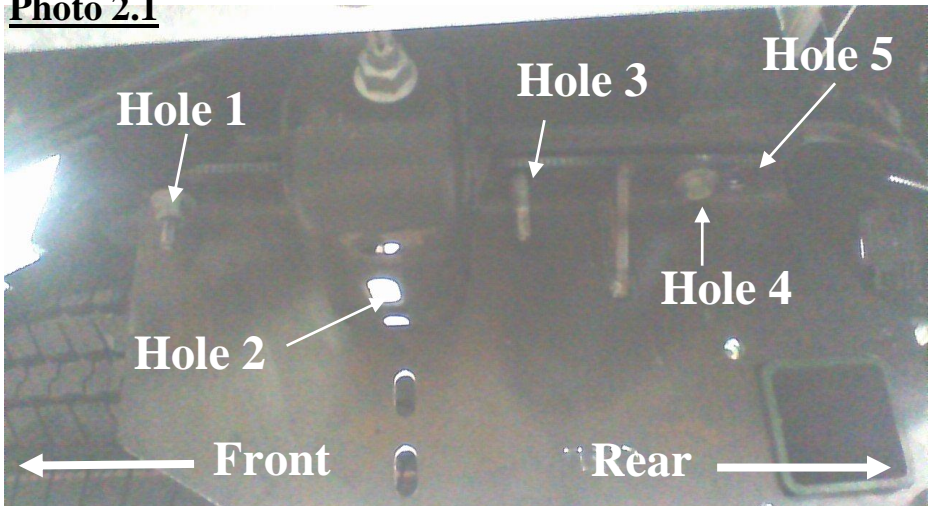

### Step 3

Above **Hole 5** in the frame there is one additional Factory Bolt connecting the frame to the bed. Remove this factory bolt.

### Step 4

Place the **Side Plate** up against the bottom of the frame, lining up **Holes 1, 3, 4, and 5** on the frame with the four holes on the **Side Plate**. Secure the **Side Plate** to the frame by hand tightening one **M14-2.0 x 40MM 10.9 Bolt** through **Hole 4** and into the weld-on Factory Nut.

### Step 5

Next, install one **M12 - 1.75 X 190 MM 10.9 Bolt** with one **1"(1.27cm) x 2"(5cm) Plate Washer** part way through **Hole 5**, place one **2"(5cm) x 2"(5cm) Center Plate Washer** inside the rear most part of the frame, centered over **Hole 5** and onto the **M12 - 1.75 X 190 MM 10.9 Bolt**.

## Step 6

Continue by placing two **1/2" Washer USS Grade 5s** and one **1/2"(1.27cm) x 4-5/8"(11.75cm) Chevy Galvanized Pipe** over the **2"(5cm) x 2"(5cm) Center Hole Plate Washer** installed in **Step 5** and onto the **M12 - 1.75 X 190 MM 10.9 Bolt**. See Photo 7.1 for an example.

## Step 7

Finally, place one more **2"(5cm) x 2"(5cm) Center Hole Plate Washer** over the **1/2"(1.27cm) x 4-5/8"(11.75cm) Chevy Galvanized Pipe** and onto the **M12 - 1.75 X 190 MM 10.9 Bolt**.

Thread the **M12 - 1.75 X 190 MM 10.9 Bolt** through the top of the frame and into the truck bed where the factory bolt was removed in **Step 3**. See Photo 7.1 for pipe and plate assembly.

**Photo 7.1**

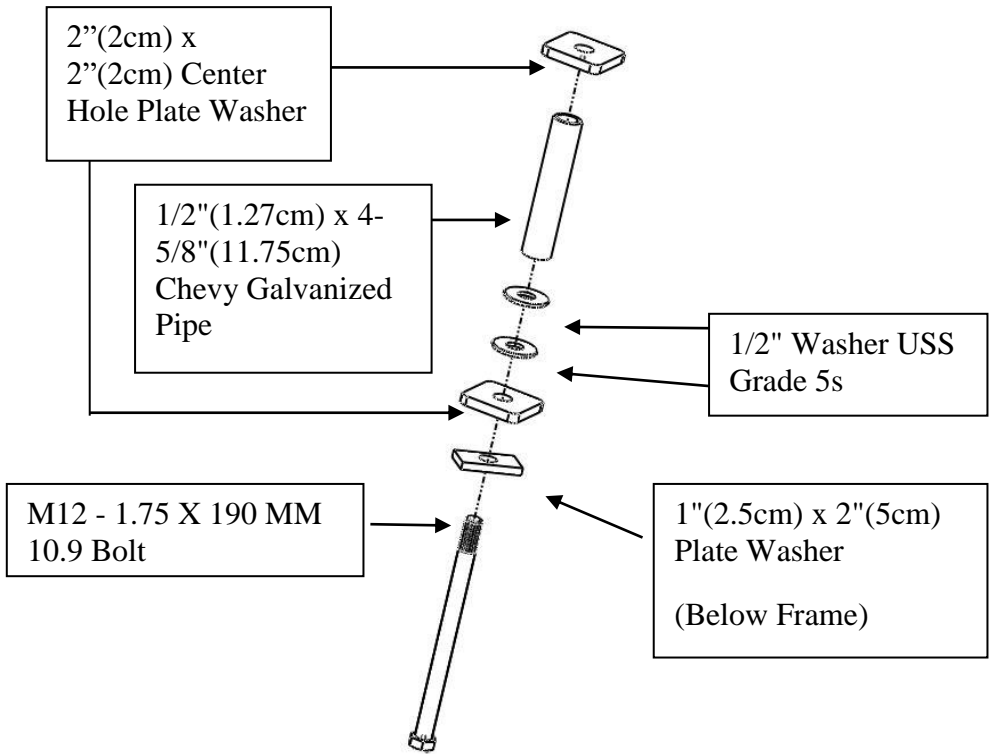

## Step 8

Next, take one **1/2" - 13 x 2" Grade 8 Hex Bolt** with one **1"(2.5cm) x 2"(5cm) Plate Washer** and install it down through **Hole 3** from the inside of the frame. Repeat this process for **Hole 1**.

## Step 9

Secure the bolts in **Hole 1** and **Hole 3** with one **1" (2.5cm) x 2" (5cm) Plate Washer**, one **1/2" Lock Washer High Alloy**, and one **1/2" - 13 Hex Nut Grade 8**. Hand tighten. See Photo 9.1 for bolt assembly reference.

**Photo 9.1**

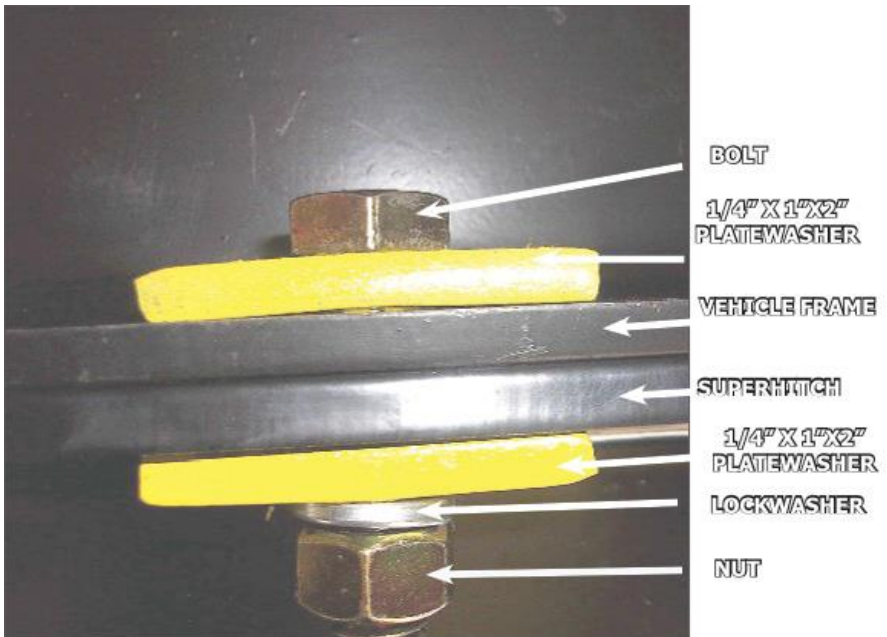

## Step 10

Place one **1/2" Star Washer** followed by one **1"(2.5cm) x 2"(5cm) Plate Washer** onto a **7/16"-14 x 1-3/4 Grade 8 Bolt**. Attach this bolt assembly to the **7/16" Bolt Fisher**. See Figure 10.1 for reference.

**Figure 10.1** - Bolt Assembly Order.

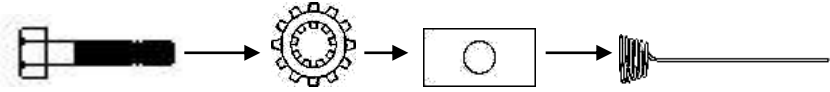

## Step 11

Fish the Bolt assembly into the large hole on the backside of the spring perch and through **Hole 2** on the spring perch. See Photo 11.1.

**Photo 11.1**

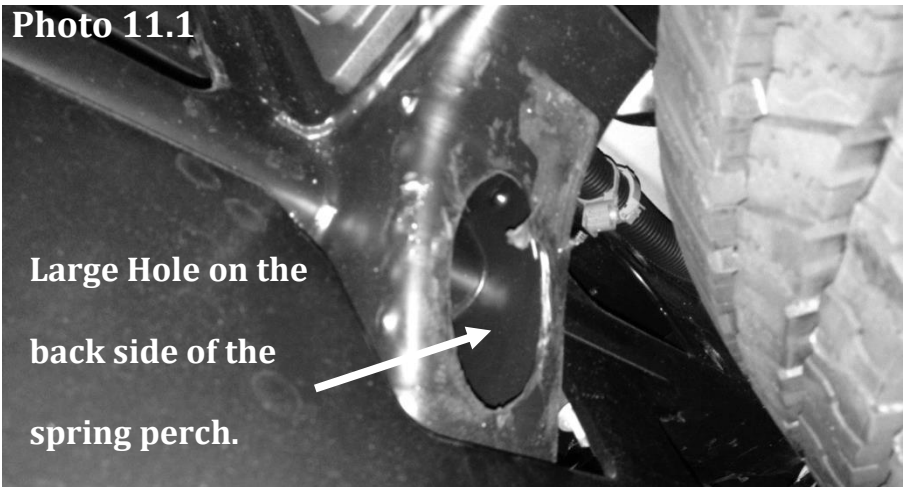

## Step 12

Repeat steps 2-11 on the driver's side.

## Step 13

Next, raise one end of the **Double Receiver Cross Tube** and place the end into the square hole on one of the **Side Plates**. Repeat the process on the other side of the **Double Receiver Cross Tube**.

*Note: We Recommend for two people to install the **Double Receiver Cross Tube** into the Super Hitch **Side Plates** to avoid personal injury.*

## Step 14

Install one  $\frac{1}{2}$ "-13 x 1- $\frac{1}{2}$ " **Grade 8 Hex Bolt** through each of the four holes in the end of the **Double Receiver Cross Tube** and out through the **Side Plates**. The threads should be facing towards the outside of the vehicle. See Photo 14.1.

**Photo 14.1**

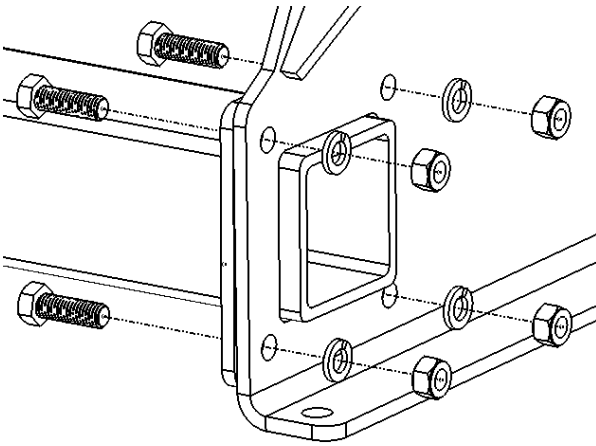

## Step 15

Secure each  $\frac{1}{2}$ "-13 x 1- $\frac{1}{2}$ " **Grade 8 Hex Bolt** on the outside of the **Side Plate** with one  $\frac{1}{2}$ " **Lock Washer**, and one  $\frac{1}{2}$ " -13 **Grade 8 Hex Nut**, hand tighten, see Figure 15.1 for reference.

**Figure 15.1**

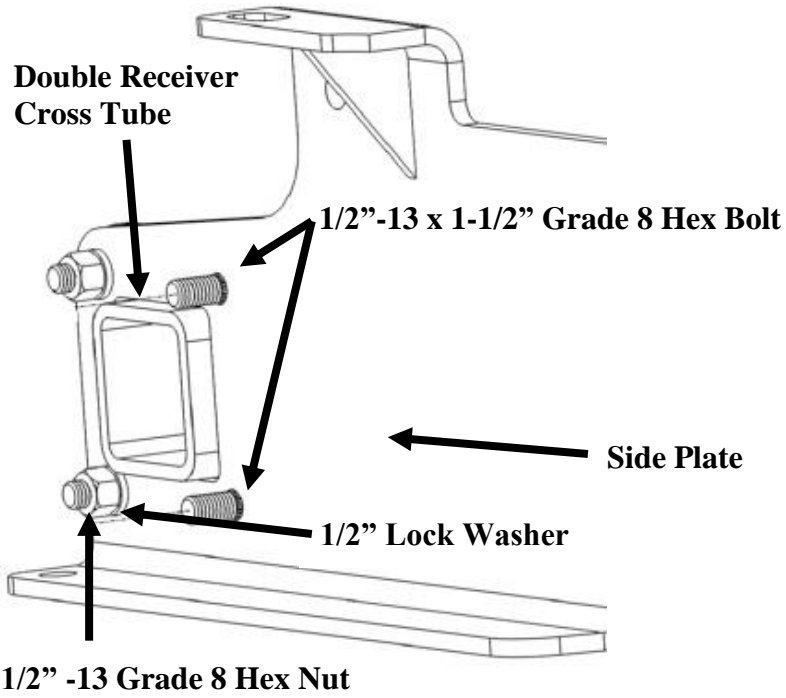

## Step 16

Lift the **Angle Support Bracket** up to the leaf spring perch with the open side facing towards the front of the truck. The side with two holes will face towards the hitch. The previously installed **7/16"-14 x 1-3/4" Grade 8 Hex Bolt** will protrude through the side with one hole. Place one **7/16" USS Flat Washer Grade 5**, followed by one **7/16" Lock Washer High Alloy**, and one **7/16" -14 Hex Nut Grade 8** onto the **7/16"-14 x 1-3/4" Grade 8 Hex Bolt**, hand tighten. See Figure 16.1.

**Figure 16.1**

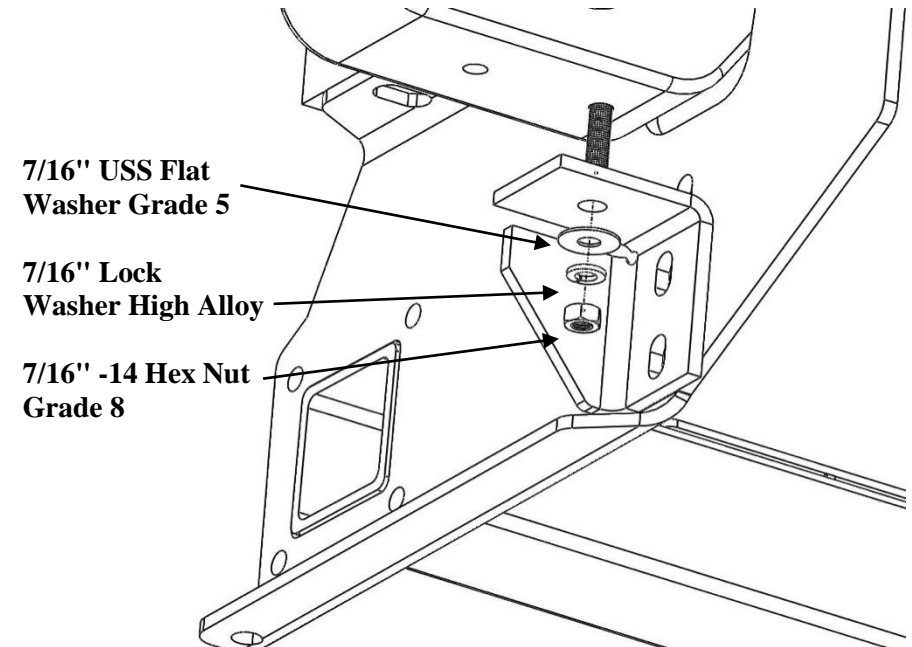

## Step 17

Line up the two **Angle Support Bracket** holes with the two holes in the **Side Plates**. Place two **1/2"-13 x 1-1/2" Grade 8 Hex Bolt** with one **1/2" Washer USS Grade 5** through each slot in the side plates and out through the **Angle Support Bracket** slots. Place one **1/2" Washer USS Grade 5**, one **1/2" Lock Washer**, and one **1/2" -13 Grade 8 Hex Nut** on each, hand tighten. Repeat on other side. See

Figure 17.1

Figure 17.1

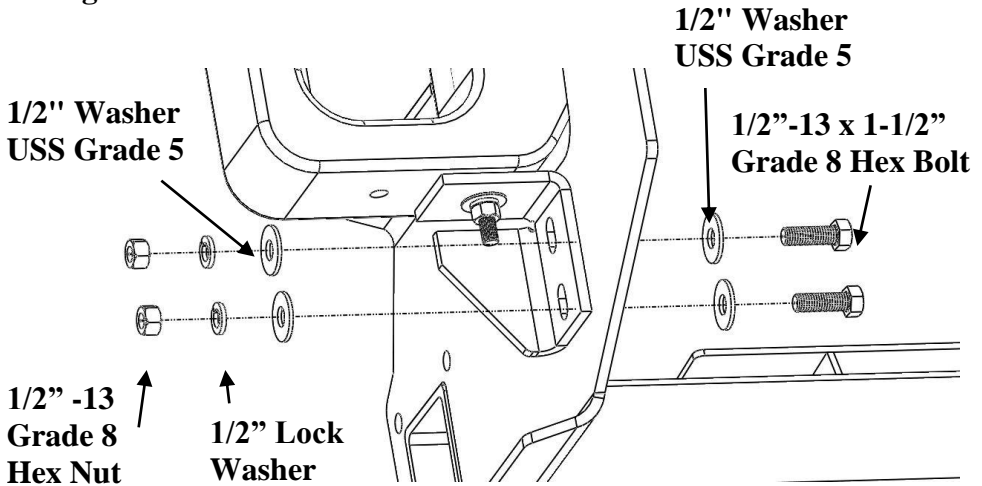

## **Step 18**

Torque parts in the following order:

1. **Side Plates** to frame
2. **Double Receiver Cross Tube** to **Side Plates**
3. **Angle Support Brackets** to **Rear Spring Perch** and **Side Plate**.

## **Torque Specifications**

Torque all **M14 Class 10.9 Bolts** and **1/2" Grade 8 Bolts** to **75 ft-lbs(101Nm)**

Torque all **M12 Class 10.9 Bolts** and **7/16" Grade 8 Bolts** to **60 ft-lbs(81Nm)**

## **Step 19**

Reinstall the Spare Tire.

**The C1208/C1208-30 Super Hitch Installation is Complete!!**

# INFORMATION ON TOWING

**TOWING EQUIPMENT OWNERS:** Make sure all of the operators of your equipment read and understand this information before towing. Save for reference. This will help you properly select, use, and maintain your towing equipment. Refer to your owner's manuals for your tow vehicle, trailer, and other parts of your towing system. Learn the capabilities and limitations of each part. The **GROSS TRAILER WEIGHT** and **TONGUE WEIGHT** are two of the most important items to consider. **THESE WEIGHTS MUST NEVER EXCEED THE LOWEST RATING OF ANY PART OF YOUR TOWING SYSTEM.** **GROSS TRAILER WEIGHT** is the weight of the trailer plus all cargo. Measure the **GROSS TRAILER WEIGHT** with the fully loaded trailer on a level surface. The weight is the downward force exerted on the ball by the trailer coupler. Measure the **TONGUE WEIGHT** with the fully loaded trailer on a level surface. The coupler must be at its normal towing height. Use a commercial scale or a bathroom scale. Set up the bathroom scale as shown for heavy tongue weights.

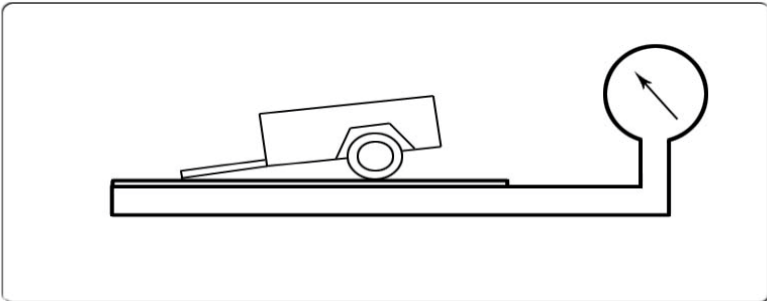

**Method for Measuring  
Gross Trailer Weight**

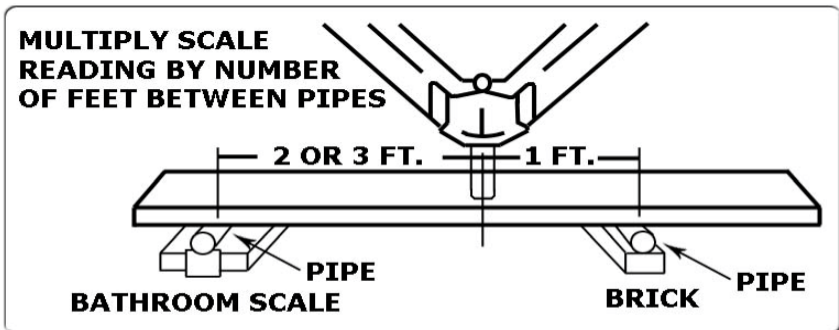

**Method for Measuring  
Trailer Tongue Weight**

# YOUR TOWING EQUIPMENT

## HITCH BALLS

Select by gross trailer weight rating, mounting platform thickness, hole size and coupler socket size. Platform must be at least 3/8 inch thick. Hole must not exceed threaded shank diameter by more than 1/16 inch. Use lock washer. Tighten per instructions. When tightened, shank must protrude beyond bottom of nut. Gross trailer weight rating and ball diameter are marked on Hitch balls.

## TRAILER COUPLERS

The coupler socket should be smooth, clean and lightly lubricated. Tighten or adjust per coupler manufacturer's instructions.

## SAFETY CHAINS

Connect safety chains properly EVERY TIME YOU TOW. Cross chains under coupler. Attach securely to the hitch or tow vehicle so they can't bounce loose. Leave only enough slack to permit full turning. Too much slack may prevent chains from maintaining control if other connections separate. Don't let chains drag on the road.

## TRAILER LIGHTS, TURN SIGNALS, ELECTRIC BRAKES AND BREAK AWAY SWITCH CONNECTIONS

Make these safety-critical connections EVERY TIME YOU TOW, no matter how short the trip. Check operation, including electric brake manual control, before getting on the road.

## SWAY CONTROLS

Sway controls can lessen the effects of sudden maneuvers, wind gusts and buffeting caused by other vehicles. We recommend them for trailers with large surface areas, such as travel trailers. Adjustable friction models can help control trailers with low tongue weight percentage.

## OTHER USEFUL EQUIPMENT

AIR SPRINGS, AIR SHOCKS or HELPER SPRINGS are useful for some hitch applications. A TRANSMISSION COOLER may be necessary for heavy towing. Many states require TOWING MIRRORS on both sides.

## TIRE INFLATION

Check often. Follow tow vehicle and trailer manufacturer's recommendations. Improper tire inflation can cause trailer sway.

**NO PASSENGERS IN TRAILERS:** NEVER allow people in trailers while towing, under any circumstances.

# HELPFUL TOWING TIPS

## TRAILER LOADING

Proper loading helps prevent sway. Place heavy object on the floor ahead of the axle. Balance the load side-to-side. Secure it to prevent shifting. Tongue weight should be 10-15 percent of gross weight for most trailers. Too low a percentage of tongue weight can cause sway. NEVER load the trailer rear heavy. LOAD THE TRAILER HEAVIER IN FRONT

## DRIVING

The additional weight of a trailer affects acceleration, braking, and handling. Allow extra time for passing, stopping, and changing lanes. Severe bumps can damage your towing vehicle, hitch, and trailer. Drive slowly on rough roads. STOP AND MAKE A THOROUGH INSPECTION IF ANY PART OF YOUR TOWING SYSTEM STRIKES THE ROAD. CORRECT ANY PROBLEMS BEFORE RESUMING TRAVEL.

## CHECK FOR EXCESSIVE SWAY AND ELIMINATE IT

Excessive sway can lead to loss of control. Sway motion should settle out quickly. Sway tends to increase on a downgrade. Starting slowly, increase speed in gradual steps. If sway occurs, adjust your trailer load and equipment. Repeat until the trailer is stable at highway speed. Do this whenever your trailer loading changes.

## IF TRAILER SUDDENLY STARTS TO SWAY

Turbulence from another vehicle, a wind gust, or a downgrade can cause sudden sway. So can a shift of the trailer's load or a trailer tire blowout. IF THE TRAILER SWAYS, IT IS THE DRIVER'S RESPONSIBILITY TO ASSESS THE SITUATION AND TAKE APPROPRIATE ACTION. Below are suggestions that may apply, depending on conditions:

## DO

- Reduce your speed gradually
- Hold the steering wheel as steady as possible
- If your trailer has electric brakes, apply the brakes alone, without using the tow vehicle's brakes.

## DON'T

- Don't hit your brake pedal hard unless absolutely necessary. A "jack-knife" can result.
- Don't try to steer out of the sway condition. Sudden or violent steering can make it worse.
- Don't speed up. Sway increases as you go faster.
- Don't continue towing a trailer that tends to sway. You may lose control during an emergency maneuver or if the conditions listed above occur.

## RECOMMENDED TRUCK CAMPER INSTALLATION INSTRUCTIONS

When securing any heavy load (especially a camper) in your truck bed, your front tie down points should pull the load forward as much as possible. Some camper anchor points may differ with different manufacturers, as well as the camper jack mounting locations. Your Torklift tie down inserts have offset triangular brackets to increase the angle of pull. These are designed to be used in the front facing forward, and the rear facing rearward but can be used in either front or rear. These recommendations are to be considered and followed as a basic rule of thumb . Obviously there will be some applications where this may not be possible. At a minimum, if opposite pull of both front and rear Tiedowns cannot be achieved for whatever reason, you should have at least a forward pull at the front or rear location. If your camper does not come with Rubber Bumpers on the front lower portion of the camper, installing Rubber Bumpers (Torklift has Rubber Bumpers available Part A7001) or using a block of wood such as a 2 x 4 in the bed, will prevent the camper from damaging the front bulk head of the truck bed. Minor movement (or settling) can occur in some incidental harsh driving conditions (on or off road). A rubber bed mat is not a requirement to maintain the lifetime warranty on a Torklift system, but a strong recommendation simply as a safety precaution to protect the truck bed, the bottom of the camper and to give the camper additional support.

**TORKLIFT DOES NOT RECOMMEND:** Installing your truck camper in your truck on top of a drop in plastic bed liner!!! The drop in plastic bed liners can slide on top of the truck bed surface, and the camper can slide on top of the slick surface of the bed liner. The liner can also act as a spring causing a trampoline effect increasing vertical truck camper movement, independent of the vehicle, possibly resulting in truck bed, and camper damage!

### INSTRUCTIONS FOR FINISH MAINTENANCE OF TORKLIFT PRODUCTS

#### **POWDER COATED STEEL:**

To keep your Torklift products looking good follow these guidelines. All steel powder coated Torklift products are sandblasted for maximum adhesion and use a high quality industrial urethane based powder coat. Due to the extreme, harsh, undercar environment that your Torklift products live in, (consistently sprayed with corrosive road chemicals such as salt, and road debris), Torklift does not warranty the power coated finish.

To minimize corrosion from these factors on powder coated steel products, Torklift recommends regularly cleaning and inspecting the powder coated surface and touching up any affected areas with an enamel or urethane based aerosol paint product. If there are any areas of surface rust, there are also aerosol spray rust converters available on the market that can be used as a preparation to touch-up paint application. These finish maintenance products are available at any automotive parts supplier.

#### **POLISHED STAINLESS STEEL :**

TorkLift utilizes quality grade 304 stainless steel in our stainless steel polished products. 304 stainless steel is well known for its anti-corrosive properties. However, in some environments such as coastal regions or when coming in contact with some road chemicals, corrosion may occur. For a quick clean simply use WD40 and a cloth rag. We also recommend occasional polishing of our polished stainless products to maintain their attractive finish. Use an approved stainless steel chrome or aluminum mag wheel polish cleaning product which can be purchased from any automotive parts supplier.



## **Frame Mounted Tie Downs**

Leading the camper tie down industry in strength, quality, advanced design and installation. TorKLift TRUE frame mounted tie downs are far superior to all tie down systems available.

The TorKLift system is unique in its design and is patented. Four independent tie down points (with no belly or crossbar) working much like your receiver type trailer hitch as the inserts are removable allowing the system to be virtually undetectable when not in use. They are designed for each make and model to fit tight to the frame so as not to compromise ground clearance. Torklift tie downs are not universal 'one size fits all' therefore all the problems with correct fit for each particular application have been eliminated.

**VISIT [WWW.TORKLIFT.COM](http://WWW.TORKLIFT.COM) FOR MORE INFORMATION**

## **Original SuperHitch & SuperHitch Magnum**

High strength extended hitch system engineered for safely towing all types of trailers behind your truck and camper. With a max towing capacity of 14,000 lbs.(6350Kg. with an extension\* , (17,000 lbs.(7711Kg) to 20,000 lbs.(9071Kg)



without\*) the Original SuperHitch and Superhitch Magnum are rated the strongest in the industry.

**CONTACT YOUR LOCAL DEALER FOR MORE DETAILS**

# **Torklift International Limited Lifetime Warranty Information**

**322 N. Railroad Ave. Kent, WA 98032**

Torklift will require proof of purchase to register, with pictures of any defective product before issuing a replacement. Torklift will not register any product without proof of purchase, which can be faxed, scanned, emailed, or mailed to the information provided below.

Torklift warrants it's hitches, custom hitch receivers, frame mounted tie downs, turnbuckles, and accessories (excluding wire harnesses which carry a 90 day warranty) from date of purchase against defects in material and workmanship under normal use and service for the ownership life of the original consumer purchaser. ALL

COMMERCIAL APPLICATIONS ARE WARRANTED FOR A PERIOD OF 90 DAYS FROM THE DATE OF

INSTALLATION/SERVICE. Torklift will replace FREE OF CHARGE any part which proves defective in material or

workmanship when presented to Torklift, TRANSPORTATION CHARGES PREPAID by purchaser, at the address above. THIS

WARRANTY IS LIMITED TO DEFECTIVE PARTS

REPLACEMENT ONLY. LABOR CHARGES AND/OR DAMAGE INCURRED IN INSTALLATION OR REPLACEMENT, AS WELL

AS INCIDENTAL AND CONSEQUENTIAL DAMAGES

CONNECTED THEREWITH ARE EXCLUDED. This warranty

does not include the finish or paint on our products. Rusting, cracking or peeling of the finish is also excluded. Some states do not allow the

exclusion or limitation of incidental or consequential damages, so the above limitation or exclusion may not apply to you. Any damage to

Torklift products as a result of misuse, abuse, neglect, accident, improper installation or any use violative of

instructions furnished by Torklift or WHEN USED IN ANY

COMMERCIAL APPLICATION WILL VOID THE WARRANTY.

This warranty gives you specific legal rights, and you may also have rights which vary from state to state. With warranty service, you may be able to go to a small claims court, a state court or a federal district court.



**322 N. Railroad Ave. Kent, WA 98032**

**Phone (800) 246-8132**

**Fax (253) 854-8003**

**Or visit our website: [www.TorkLift.com](http://www.TorkLift.com)**

Dear Valued Customer,

Thank you for making TorkLift your choice for truck, camper packages and accessories for your vehicle. By choosing TorkLift products, you have chosen a company that has been serving the RV industry for nearly 40 years and whose name has become synonymous with strength, quality and advanced design and installation.

Please take a few moments of your time to complete the Product Registration Warranty Card on the next page. When registering your newly purchased TorkLift products, you can be assured that your contact information is secure and that you and your product are getting the attention and respect that you deserve.

Thank you again for choosing TorkLift quality products.

**Register for your lifetime warranty and receive a free  
Torklift  
International gift.**

To Fax: Send copies of the questionnaire, warranty card and receipt to  
253-854-8003

To E-mail: Send copies of the questionnaire, warranty card and receipt to  
[warranty@torklift.com](mailto:warranty@torklift.com)

To Mail: Send to Torklift International 322 N Railroad Ave Kent WA 98032



## OFFICIAL WARRANTY REGISTRATION CARD

PLEASE FILL OUT THIS FORM COMPLETELY AND RETURN TO TORKLIFT WITHIN

30 DAYS OF PURCHASE ACCOMPANIED BY A COPY OF YOUR ORIGINAL RECEIPT

### 1. PART(S) PURCHASED

TODAY'S DATE: \_\_\_\_\_

PART #: \_\_\_\_\_ PART #: \_\_\_\_\_

PART #: \_\_\_\_\_ PART #: \_\_\_\_\_

PART #: \_\_\_\_\_ PART #: \_\_\_\_\_

### 2. PURCHASER INFORMATION

NAME: \_\_\_\_\_

ADDRESS: \_\_\_\_\_

CITY: \_\_\_\_\_ STATE: \_\_\_\_\_ ZIP / POSTAL CODE: \_\_\_\_\_

PHONE: (\_\_\_\_) \_\_\_\_\_ - \_\_\_\_\_ EMAIL: \_\_\_\_\_

### 3. TRUCK INFORMATION

YEAR: \_\_\_\_\_ MAKE: \_\_\_\_\_

MODEL: \_\_\_\_\_ BED LENGTH: \_\_\_\_\_

### 4. CAMPER INFORMATION

YEAR: \_\_\_\_\_ MAKE: \_\_\_\_\_ MODEL: \_\_\_\_\_

### 5. DEALER INFORMATION

PURCHASED FROM: \_\_\_\_\_

ADDRESS: \_\_\_\_\_

CITY: \_\_\_\_\_ STATE: \_\_\_\_\_ ZIP / POSTAL: \_\_\_\_\_

INSTALLED BY: \_\_\_\_\_ OWNER ABOVE DEALER ANOTHER DEALER

IF ANOTHER DEALER, WHO: \_\_\_\_\_