



# **TORKLIFT**

---

# **I N T E R N A T I O N A L**

**OVER 40 YEARS OF INNOVATION, QUALITY, SAFETY.  
IMPORTANT OWNER-OPERATOR INSTALLATION INSTRUCTIONS**

## **C2226**

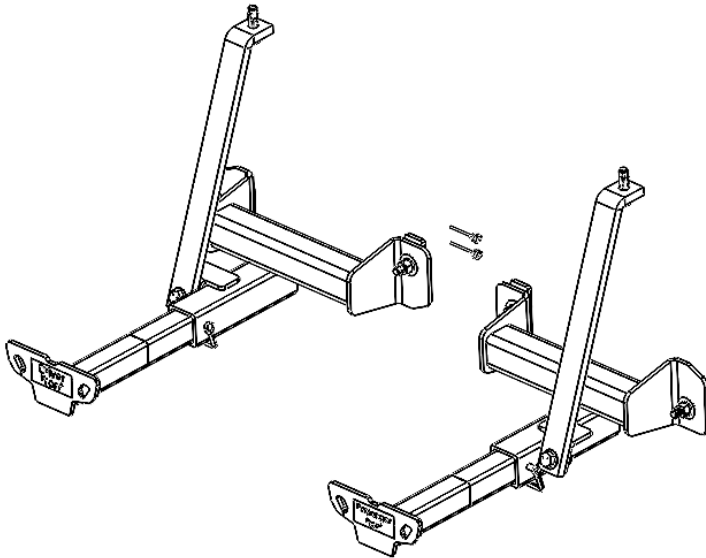

Version Number: 4, Date: 7/15/2022 By: CW

**TECH SUPPORT (800) 246-8132**

**AFTER INSTALL, PLEASE GIVE  
THIS BOOKLET TO YOUR CUSTOMER**

# Warnings

## Truck Bed and Camper Protection

Torklift **does not** recommend installing your camper on top of a plastic bed liner (or other compressible material such as foam). These materials can act as a spring, causing increased vertical truck camper movement independent of the vehicle. Plastic bed liners can slide on the truck bed surface, and the truck camper can slide on top of the bed liner. Using a plastic bed liner or similar compressible material will void your warranty and may additionally cause truck bed and/or camper damage.







Minor movement or settling can occur in some incidental harsh driving conditions (on or off-road). A rubber bed mat is recommended to protect the truck bed and camper, but is not a requirement to maintain the Torklift legendary lifetime warranty.



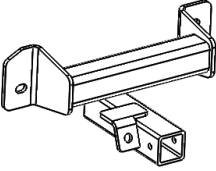
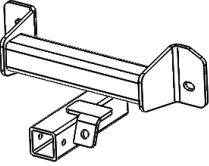

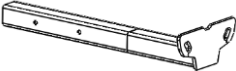
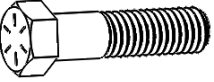
## Suspension

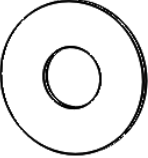
To significantly reduce body roll, sag and sway Torklift strongly recommends the StableLoad. Torklift International StableLoads improve safety, handling, and to help level your truck. More information can be found at ([www.Torklift.com/stableload](http://www.Torklift.com/stableload)).

If your truck is additionally equipped with suspension air bags Torklift cautions against over pressurization as this may lead to unsafe vehicle handling characteristics. We have found that airbags used in conjunction with StableLoads have allowed operators to lower air bag pressure by 50% or more. Only pressurize suspension air bags enough to level the truck.

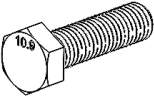
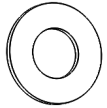
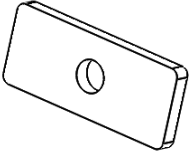
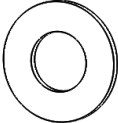
## Parts Inventory

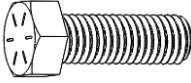
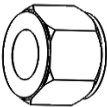
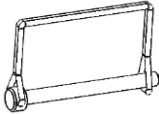
Item Image	Item Description	Item #	QTY
	Driver Side Tie Down Receiver	C2226-W1-D	1
	Passenger Side Tie Down Receiver	C2226-W1-P	1
	Receiver Brace	TD-FB-MS-S2	2
	17-7/8" Straight Tie Down Insert	TD-INS-MS-W12	2
	7/16"-14 x 1-3/4" Grade 8 Hex Bolt	10317	4
	7/16" Star Washer	11998	4
	7/16" USS Flat Washer	3536	4
	7/16" Split Lock Washer	3311	4
	7/16"-14 Grade 8 Hex Nut	9962	4

Item Image	Item Description	Item #	QTY
	M12-1.75 x 45mm - Hex Bolt – Class 10.9	20001	2
	M12 Flat Washer	20003	2
	1-1/4" x 3" x 1/4" – Plate Washer	TL-HW-PW- P35	4
	1/2" SAE Flat Washer	7465	2
	1/2" Split Lock Washer	9302	2
	1/2"-13 x 1-1/2" Grade 8 Hex Bolt	9960	2
	1/2"-13 Grade 8 Hex Nut	1751	2
	1/4" x 1-1/4" Bail Pin	1452	2
	Driver Front Insert Sticker	3844	1
	Passenger Front Insert Sticker	3845	1
	7/16" Bolt Fisher	12031	2

## Installation Notes:

### Step 1:

- On the driver side frame rail, insert the coiled end of a 7/16" bolt fisher into the round hole just forward of the front bed support bracket. See Figure 1.1
- Guide the coiled end of the bolt fisher out through the oval hole rearward of the front bed support bracket. Do not let the straight end of the bolt fisher fall into the frame.
- Install one plate washer and one 7/16" star washer over the coiled end of the bolt fisher, then attach the bolt fisher to a 7/16"-14 x 1-3/4" grade 8 hex bolt.

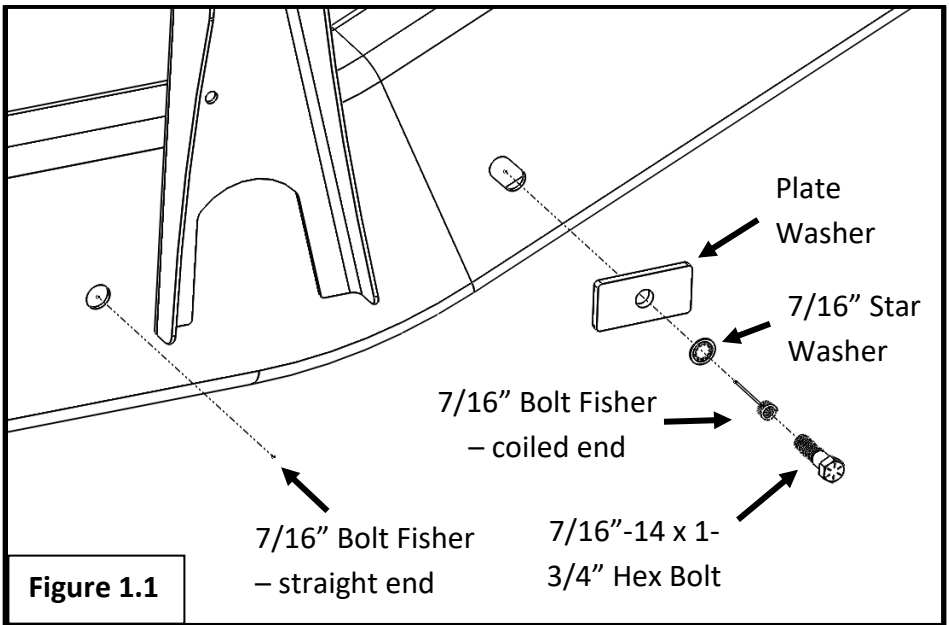

- Feed the plate washer, star washer, and bolt into the frame separately, then gently pull on the straight end of the bolt fisher until the threads of the bolt protrude out of the round hole in the frame. Leave the bolt fisher attached.

## Step 2:

- Place a plate washer and a 7/16" star washer over the coiled end of another 7/16" bolt fisher.
- Attach the coiled end of the bolt fisher to another 7/16"x1-3/4" hex bolt. See Figure 2.1

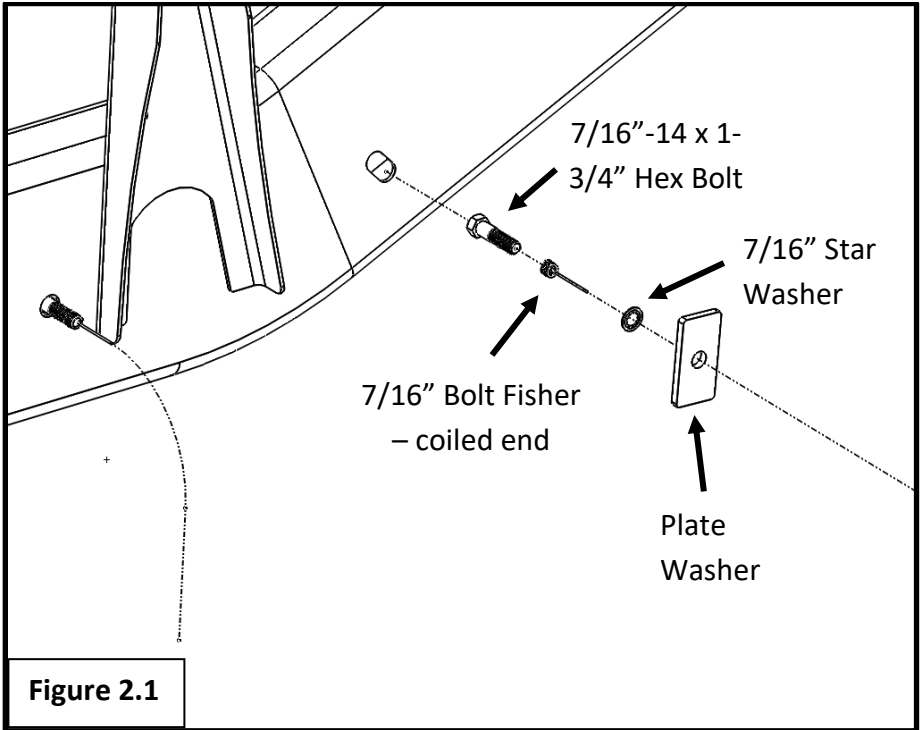

- Insert the bolt, star washer, and plate washer into the oval hole in the frame separately. Do not allow the straight end of the bolt fisher to go into the frame.
- Gently pull on the straight end of the bolt fisher until the threads of the bolt protrude out of the oval hole in the frame. Leave the bolt fisher attached.

### Step 3:

- Guide the straight end of each bolt fisher through the two holes in the driver side tie down receiver as shown in Figure 3.1
- Place the tie down receiver up against the frame.
- Use the straight end of each bolt fisher to pull the bolts through the tie down receiver holes.

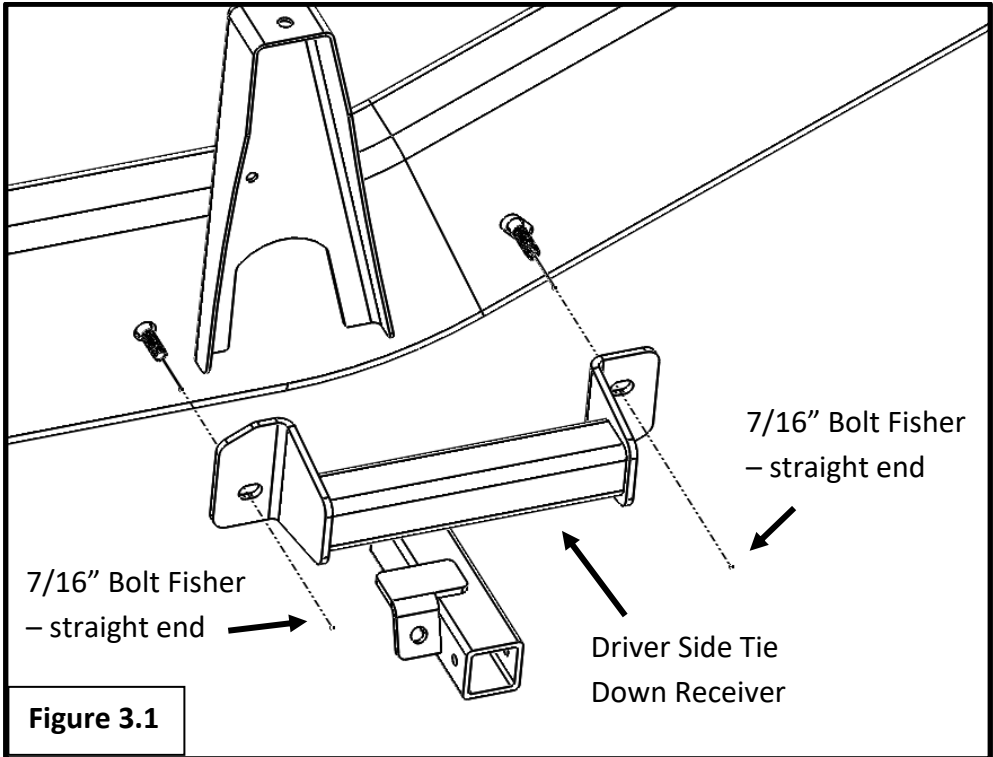

- Carefully remove one of the bolt fishers, then loosely secure the bolt with one 7/16" USS flat washer, one 7/16" split lock washer, and one 7/16"-14 grade 8 hex nut.
- Once the first bolt is secure, repeat the process on the second bolt. Leave the hardware loosely installed. See Figure 3.2

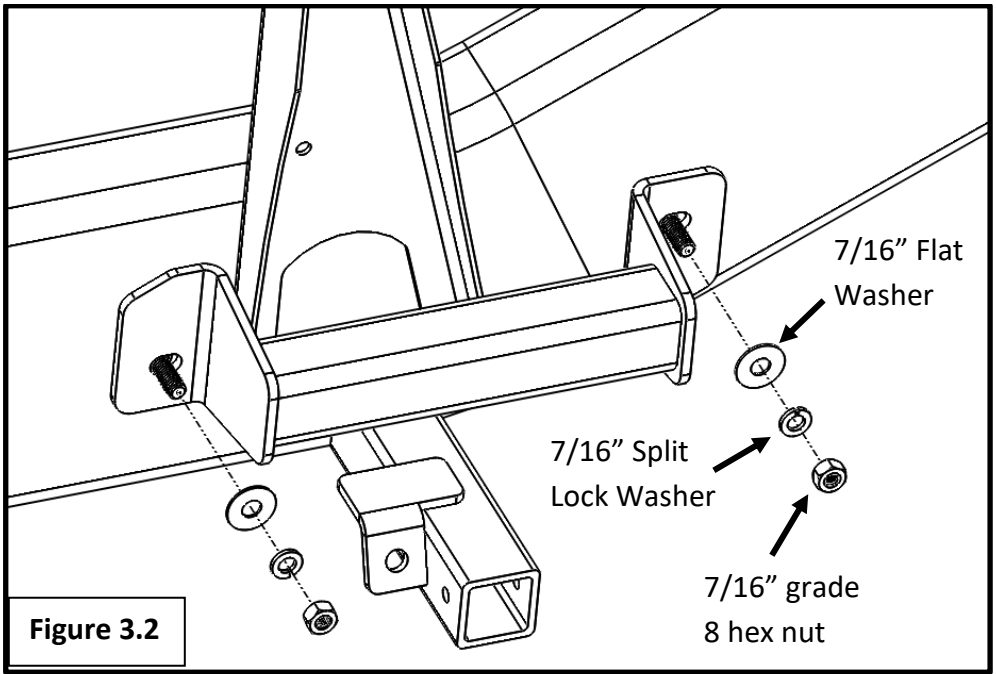

#### Step 4:

- Remove the factory bolt at the top of the bed support bracket. **Discard this factory bolt.** See Figure 4.1.

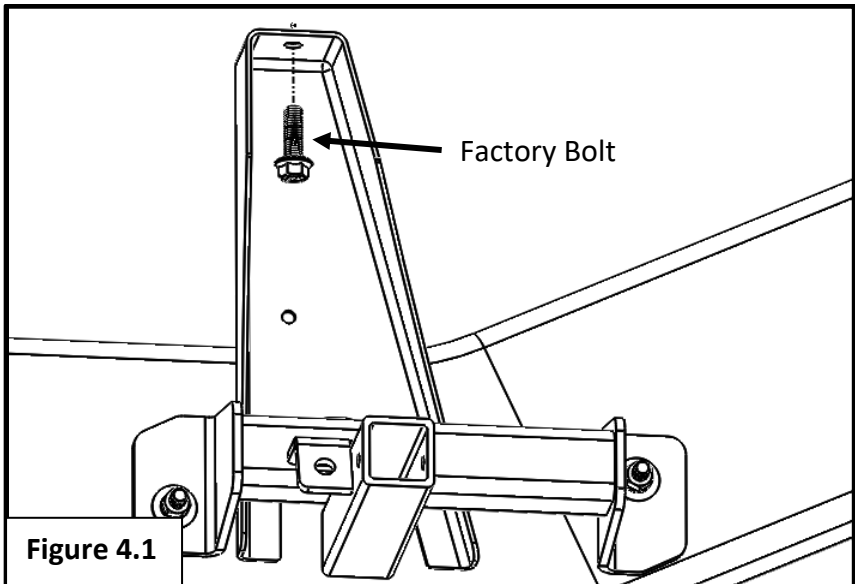

## Step 4 Cont.:

- Using an M12-1.75 x 45mm bolt with one M12 flat washer, loosely attach a receiver brace to the hole at the top of the bed support as shown in Figure 4.2.

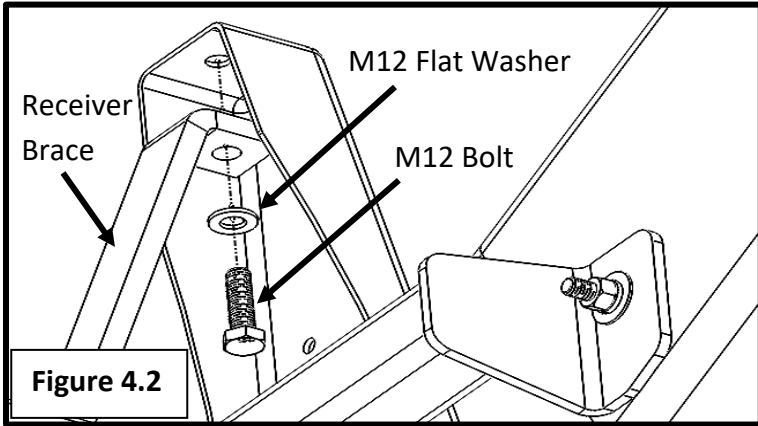

## Step 5:

- Insert a 1/2"-13 x 1-1/2" grade 8 hex bolt through a 1/2" SAE flat washer, the receiver brace, and the tie down receiver. See Figure 5.1.
- Secure the bolt with a 1/2" split lock washer and a 1/2"-13 grade 8 hex nut.

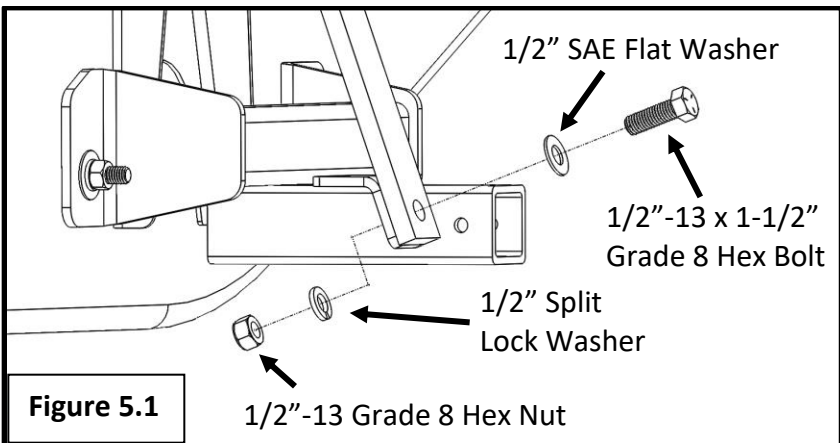

## Step 6:

Torque the hardware in the following sequence

1. M12 hardware            60 ft-lbs (108 Nm)
2. 1/2" hardware            75 ft-lbs (100 Nm)
3. 7/16" hardware           65 ft-lbs (88 Nm)

## Step 7:

Repeat Steps 1-6 on the passenger side of the vehicle.

## Step 8:

Slide a tie down insert into each receiver. The holes in the tie down insert end plates should be offset towards the top of the tube.

Use a 1/4" x 2-1/4" bail pin to secure the tie down inserts in place. Either hole in the insert can be used if there is sufficient clearance between the turnbuckles and vehicle body. We recommend at least 1".

The tiedown inserts can be removed when not in use.

***IMPORTANT NOTE: Your tie down inserts are designed to have clearance inside of the receiver. This is to account for road debris, as well as aid in installation and removal. Some rattle may be expected if the inserts are left installed while not under load from the camper.***

**Installation is complete.**

# **Torklift International Limited Lifetime Warranty Information**

322 Railroad Ave North, Kent, WA 98032

Torklift will require proof of purchase to register, with pictures of any defective product before issuing a replacement. Torklift will not register any product without proof of purchase, which can be faxed, scanned, emailed, or mailed to the information provided below. Torklift warrants its hitches, custom hitch receivers, frame mounted tie downs, turnbuckles, and accessories (excluding wire harnesses which carry a 90 day warranty) from date of purchase against defects in material and workmanship under normal use and service for the ownership life of the original consumer purchaser. All plastic, rubber, and/ or electrical components maintain a warranty of up to one year from the date of the purchase. **ALL COMMERCIAL APPLICATIONS ARE WARRANTED FOR A PERIOD OF 90 DAYS FROM THE DATE OF INSTALLATION/SERVICE.** Torklift will replace **FREE OF CHARGE** any part which proves defective in material or workmanship when presented to Torklift, **TRANSPORTATION CHARGES PREPAID** by purchaser, at the address above. **THIS WARRANTY IS LIMITED TO DEFECTIVE PARTS REPLACEMENT ONLY. LABOR CHARGES AND/OR DAMAGE INCURRED IN INSTALLATION OR REPLACEMENT, AS WELL AS INCIDENTAL AND CONSEQUENTIAL DAMAGES CONNECTED THEREWITH ARE EXCLUDED.** This warranty does not include the finish or paint on our products. Rusting, cracking or peeling of the finish is also excluded. Some states do not allow the exclusion or limitation of incidental or consequential damages, so the above limitation or exclusion may not apply to you. Any damage to Torklift products as a result of misuse, abuse, neglect, accident, improper installation or any use violation of instructions furnished by Torklift or **WHEN USED IN ANY COMMERCIAL APPLICATION WILL VOID THE WARRANTY.** This warranty gives you specific legal rights, and you may also have rights which vary from state to state. With warranty service, you may be able to go to a small claims court, a state court or a federal district court.



## ***INTERNATIONAL***

**322 Railroad Ave North, Kent, WA 98032**

**Phone (800) 246-8132 Fax (253) 854-8003**

**Or visit our website: [www.TorkLift.com](http://www.TorkLift.com)**

Dear Valued Customer,

Thank you for making TorkLift your choice for truck, camper packages and accessories for your vehicle. By choosing TorkLift products, you have chosen a company that has been serving the RV industry for nearly 40 years and whose name has become synonymous with strength, quality and advanced design and installation.

Please take a few moments of your time to complete the Product Registration Warranty Card on the next page. When registering your newly purchased TorkLift products, you can be assured that your contact information is secure and that you and your product are getting the attention and respect that you deserve.

Thank you again for choosing TorkLift quality products.

**Register for your lifetime warranty and receive a free Torklift International gift.**

To Fax: Send copies of the questionnaire, warranty card and receipt to  
253-854-8003

To E-mail: Send copies of the questionnaire, warranty card and receipt to  
[warranty@torklift.com](mailto:warranty@torklift.com)

To Mail: Send to Torklift International 322 Railroad Ave North, Kent, WA 98032



## OFFICIAL WARRANTY REGISTRATION CARD

**322 Railroad Ave North, Kent, Wa 98032**

Please fill out this form completely and return to Torklift within 30 days of purchase accompanied by a copy of your original receipt

### 1. PART(S) PURCHASED

TODAY'S DATE: \_\_\_\_\_

PART#: \_\_\_\_\_ PART#: \_\_\_\_\_

PART#: \_\_\_\_\_ PART#: \_\_\_\_\_

PART#: \_\_\_\_\_ PART#: \_\_\_\_\_

### 2. PURCHASER INFORMATION

NAME: \_\_\_\_\_

ADDRESS: \_\_\_\_\_

CITY: \_\_\_\_\_ STATE: \_\_\_\_\_ ZIP / POSTAL CODE: \_\_\_\_\_

PHONE: (\_\_\_\_) \_\_\_\_\_ - \_\_\_\_\_ EMAIL: \_\_\_\_\_

### 3. TRUCK INFORMATION

YEAR: \_\_\_\_\_ MAKE: \_\_\_\_\_

MODEL: \_\_\_\_\_ BED LENGTH: \_\_\_\_\_

### 4. CAMPER INFORMATION

YEAR: \_\_\_\_\_ MAKE: \_\_\_\_\_ MODEL: \_\_\_\_\_

### 5. DEALER INFORMATION

PURCHASED FROM: \_\_\_\_\_

ADDRESS: \_\_\_\_\_

CITY: \_\_\_\_\_ STATE: \_\_\_\_\_ ZIP / POSTAL: \_\_\_\_\_

INSTALLED BY: \_\_\_\_\_ OWNER ABOVE DEALER ANOTHER DEALER

IF ANOTHER DEALER, WHO: \_\_\_\_\_