

TORKLIFT INTERNATIONAL

**OVER 35 YEARS OF INNOVATION, QUALITY, SAFETY.
IMPORTANT OWNER-OPERATOR INSTALLATION INSTRUCTIONS**

Part # D1108-30

Owner's Manual

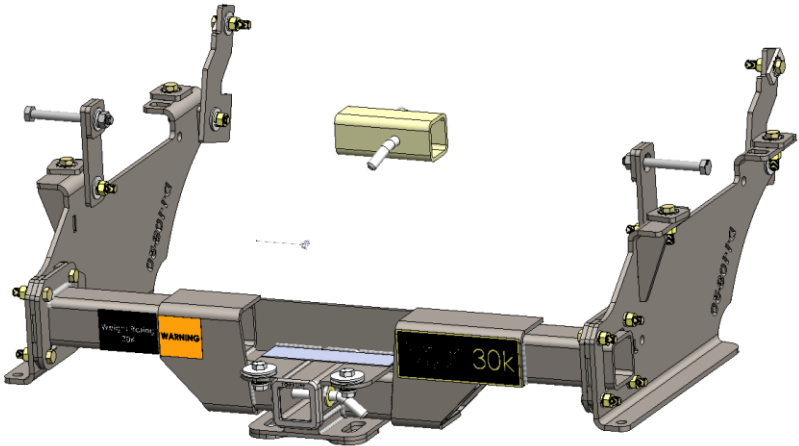

Version 6 BY: CW 8-12-2019

TECH SUPPORT (800) 246-8132

**AFTER INSTALL, PLEASE GIVE
THIS BOOKLET TO YOUR CUSTOMER**

Hitch Weight Capacity

Weight Carry

20,000 lbs maximum pull weight
2,500 lbs maximum tongue weight







Weight Distribution

30,000 lbs maximum pull weight
3,000 lbs maximum tongue weight.

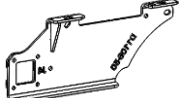
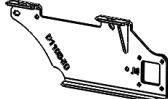
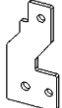

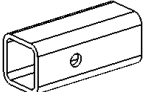

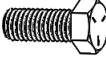
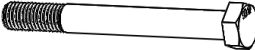
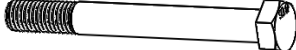



Warning

Do not exceed the factory weight ratings of
your vehicle



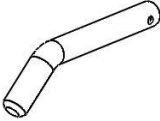

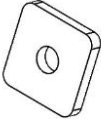
Parts Inventory

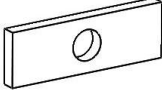
Item Image	Item Description	Item #	QTY
	30K Super Hitch Cross Tube	SH-3.00-38.00-A7	1
	D1104-30 Passenger Side Plate	D1104-30-W1-P-BK62	1
	D1104-30 Driver Side Plate	D1104-30-W1-D-BK62	1
	Front Side Strap	SH-SS-P5-BK62	2
	6-3/8" x 2-1/4" Rear Side Strap	SH-SS-P9-BK62	2
	2" x 2" Receiver Adapter	SH-RA-2.50-S1-Zinc	1
	1/2" Star Washer	4566	6
	1/2"-13 x 2" Grade 8 Hex Bolt	3659	18
	1/2"-13 x 1-1/4" Grade 5 Hex Bolt	7321	2
	M14-2.00 x 130mm Class 10.9 Hex Bolt	11072	2
	M16-2.00 x 130mm Class 10.9 Hex Bolt	13479	2
	M14-2.00 Class 10.9 Hex Nut	10366	2

Parts Inventory

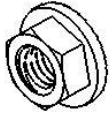
Item Image	Item Description	Item #	QTY
	M16-2.00 Class 10.9 Hex Nut	13480	2
	1/2"-13 Grade 8 Hex Nut	1751	18
	1/2" USS Flat Washer	6039	26
	1/2" Lock Washer	9302	20
	1/2" Bolt Fisher	3818	1
	5/8" Pin and Clip	3703	2
	1/2" x 2" x 3/16" Fender Washer	4623	4
	1-3/8" ID x 2-1/4" OD x 5/16" Plate Washer	TL-HW- PW-P32	2
	2" x 2" x 5/16" Center Hole Plate Washer	11403	6
	1" x 2" x 1/4" Plate Washer	10859	2
	1" x 3" x 1/4" Plate Washer	11721	2

Parts Inventory

Item Image	Item Description	Item #	QTY
	1/2"-13 Grade 5 Serrated Flange Nut	7181	2
	1/2" x 2" x 1/16" Fender Washer	12461	2
	5/8" USS Flat Washer	6089	6
	5/8" Split Lock Washer	6023	2
	2" x 8-1/4" UHMW Strip	Shear- 11683- 8.25	1

Step 1

Temporarily remove spare tire, and loosen the six bolts (three per side) holding in the factory hitch to the side of the frame. These bolts must be loosened to aid in aligning the factory hitch receiver to the Super Hitch. Begin the installation process on the passenger side of the vehicle.

Step 2

- Attach a 1"x 3"x1/4" Plate Washer, one 1/2" Star Washer and one 1/2" x 2" Hex Bolt to the 1/2" Bolt Fisher. See figure 2.1.
- Leave the hardware separated on the bolt fisher.

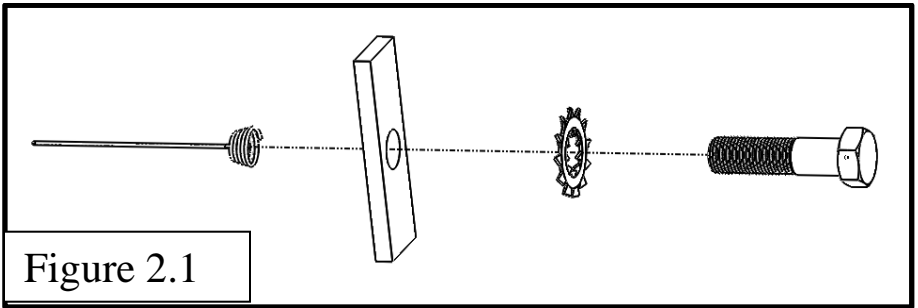

- Insert the hardware through Hole #1 in the frame rail, then pull on the wire end of the bolt fisher to seat the 1/2" x 2" Grade 5 Hex Bolt through the two washers. It may be necessary to temporarily remove the heat shield to access this hole. See figure 2.2.
- The 1"x3"x1/4" Plate Washer should be holding the hardware inside of the frame, with the bolt fisher and the threaded end of the bolt on the outside of the frame. See figure 2.3

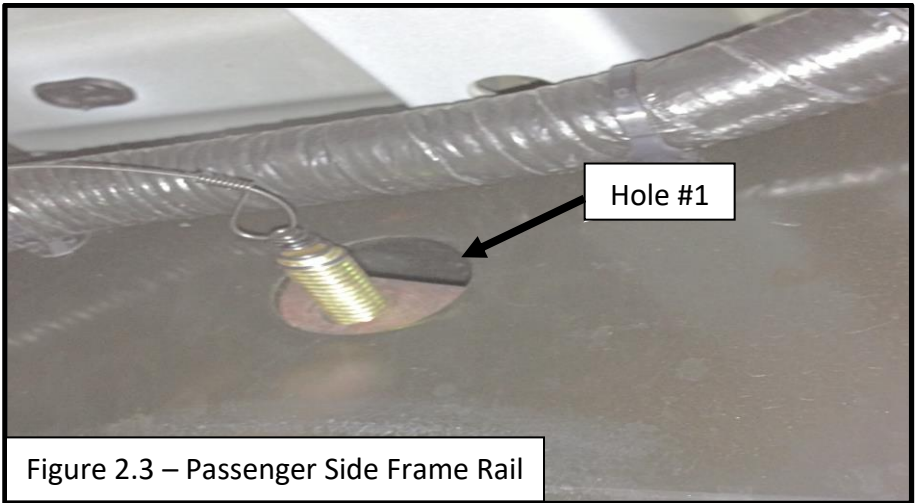
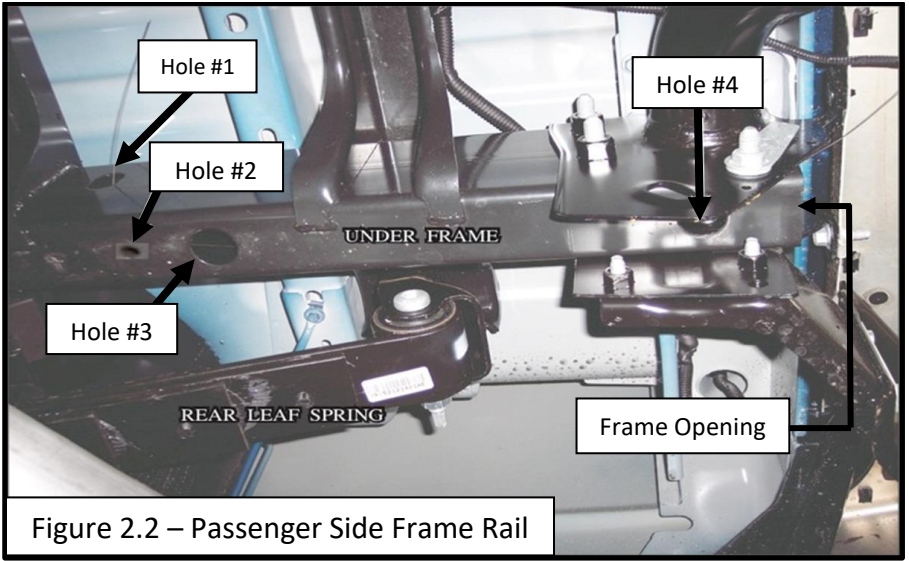

Step 3

- Carefully slide the Front Side Strap onto the bolt fisher wire and onto the bolt.
- Remove the bolt fisher and loosely install one 1/2" Flat Washer, one 1/2" Lock Washer, and one 1/2"-13 Grade 8 Hex Nut. See Photo 3.1

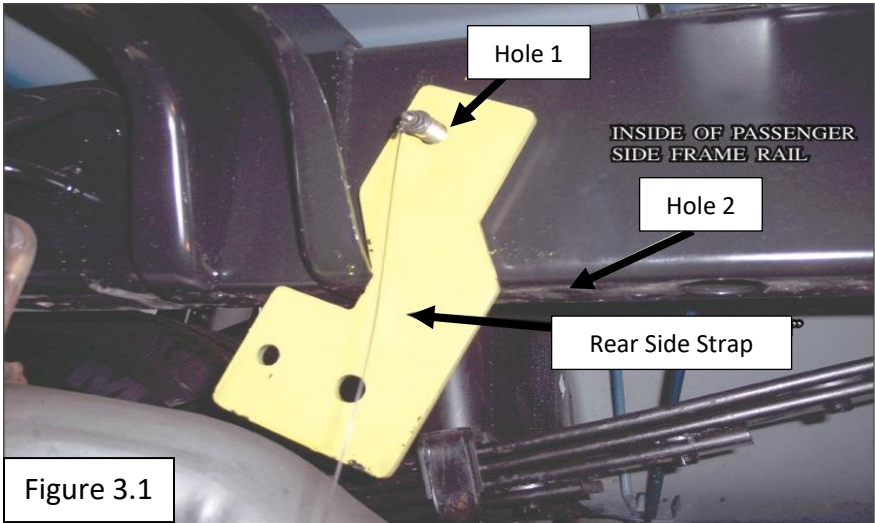

Step 4

Short Bed Installation

- Insert the coiled end of the bolt fisher into Hole #2, and guide it out through Hole #3. See figure 2.2.
- Attach a 1"x 2"x1/4" Plate Washer, one 1/2" Star Washer and one 1/2" x 2" Hex Bolt to the 1/2" Bolt Fisher. See figure 4.1.

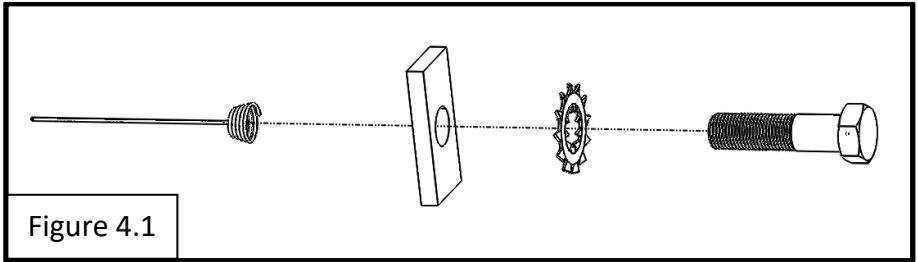

- Pull the wire end of the bolt fisher to guide the threaded end of the bolt back out through Hole #3, Then carefully disconnect the bolt fisher

Long Bed Installation

- Insert the coiled end of the bolt fisher into Hole#3, and guide it out through the opening in the end of the frame. See figure 2.2
- Attach one 2"x2"x5/16" Center Hole Plate Washer, one 1/2" Star Washer, and one 1/2"x2" Grade 5 Hex Bolt to the coiled end of the bolt fisher.
- Pull on the wire end of the bolt fisher until the threaded end of the bolt protrudes from Hole #3. Carefully remove the bolt fisher.

Step 5

- Insert A screw Driver, or the end of a socket wrench up through Hole #4. Slide a 2"x2"x5/16" Center Hole Plate Washer into the opening in the end of the frame. The item inserted into Hole #4 will keep the plate washer from sliding too far into the frame. See Figure 5.1.



- Carefully remove the screw driver/socket wrench, and align the hole in the Center Hole plate washer with Hole #4. See Figure 5.2
- Continued on next page.

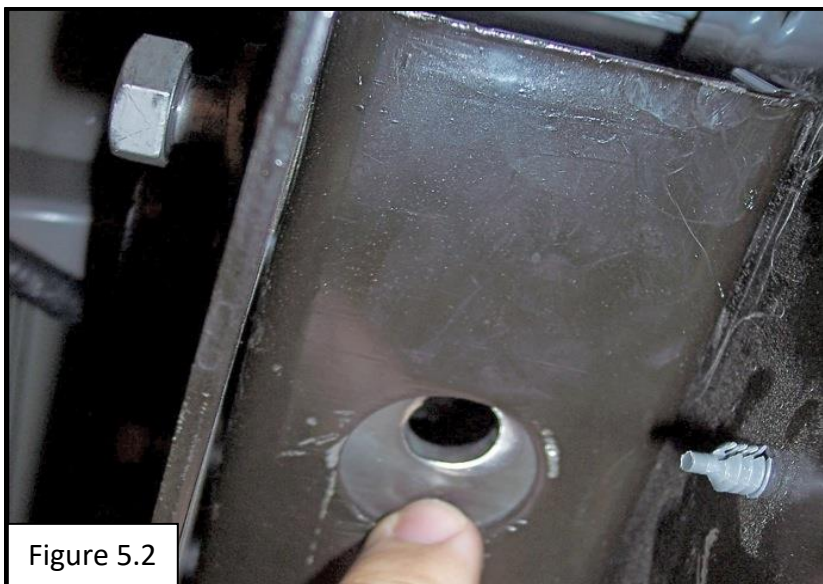

Figure 5.2

- Guide the coiled end of the bolt fisher up through the center hole plate washer and into the hole in the bottom of the factory hitch cross tube. Continue to guide the bolt fisher out the end of the factory hitch cross tube.
- Attach one 1/2" Star Washer and one 1/2"x2" Grade 5 Hex Bolt to the bolt fisher, then pull on the wire end of the bolt fisher to guide the 1/2"x2" Grade 5 Hex Bolt through the Center Hole Plate Washer.

Step 6

- On this installation, the Super Hitch Side Plates have both the top and bottom flanges bent towards the outside of the vehicle.
- Choose the correct side plate, and carefully raise it into position against the bottom of the frame. Be sure not to push the previously installed bolts back into the frame, as retrieving them can be difficult.

- Secure each of the previously installed bolts with two 1/2” Flat Washers, one 1/2” Lock Washer, and one 1/2”-13 Grade 8 Nut. Leave the hardware loose.

Step 7

- Remove the front lower factory hitch mounting bolt as shown in Figure 7.1.
 - On 2013-2017 vehicles, Replace the bolt with a 14mm-2.00 x 130mm Class 10.9 Hex Bolt and one 1/2” USS Flat Washer
 - On 2018 vehicles, Replace the bolt with a 16mm-2.00 x 130mm Class 10.9 Hex Bolt and one 5/8” USS Flat Washer.



- Install one 1/2”x2” grade 8 hex bolt with two 1/2” flat washers through the side of the Super Hitch Side Plate and out through the slotted hole in the factory hitch plate as shown in figure 7.2.

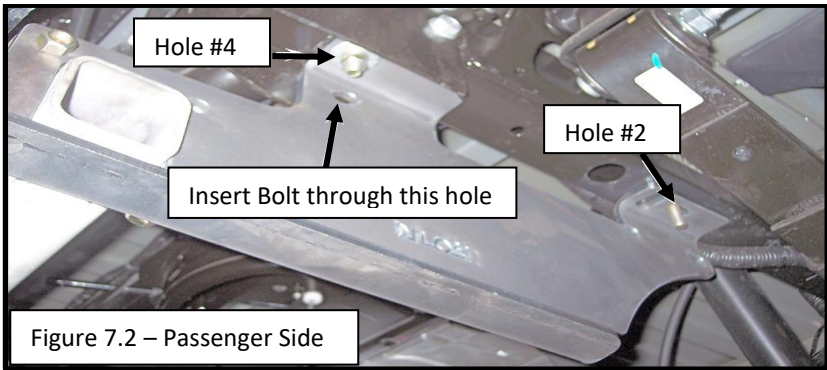
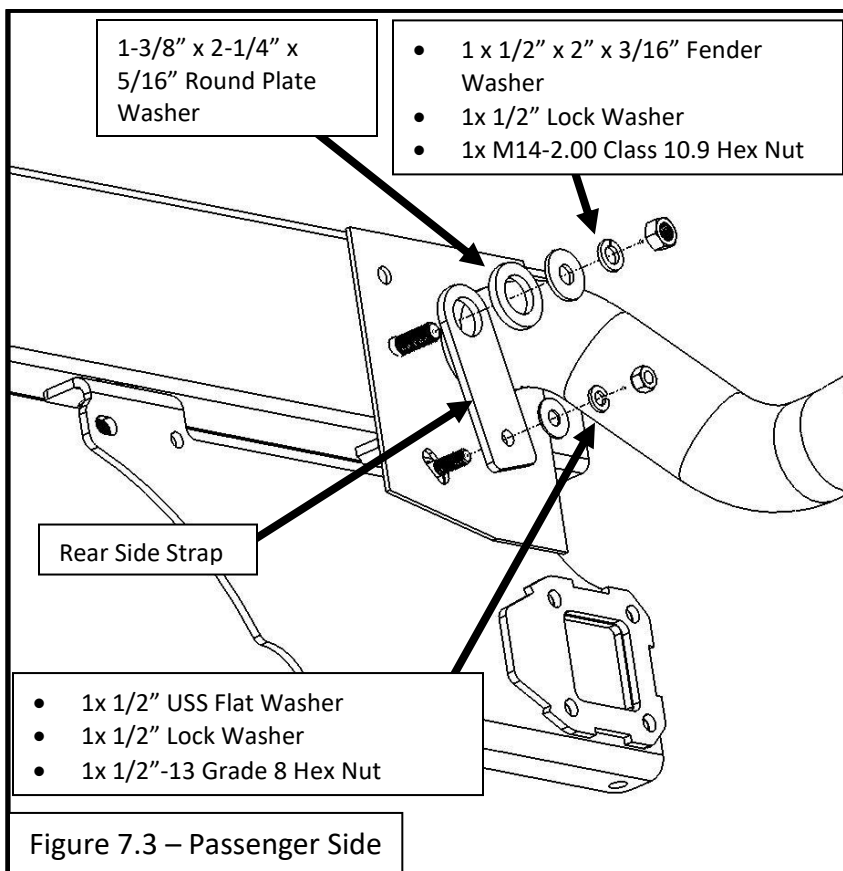
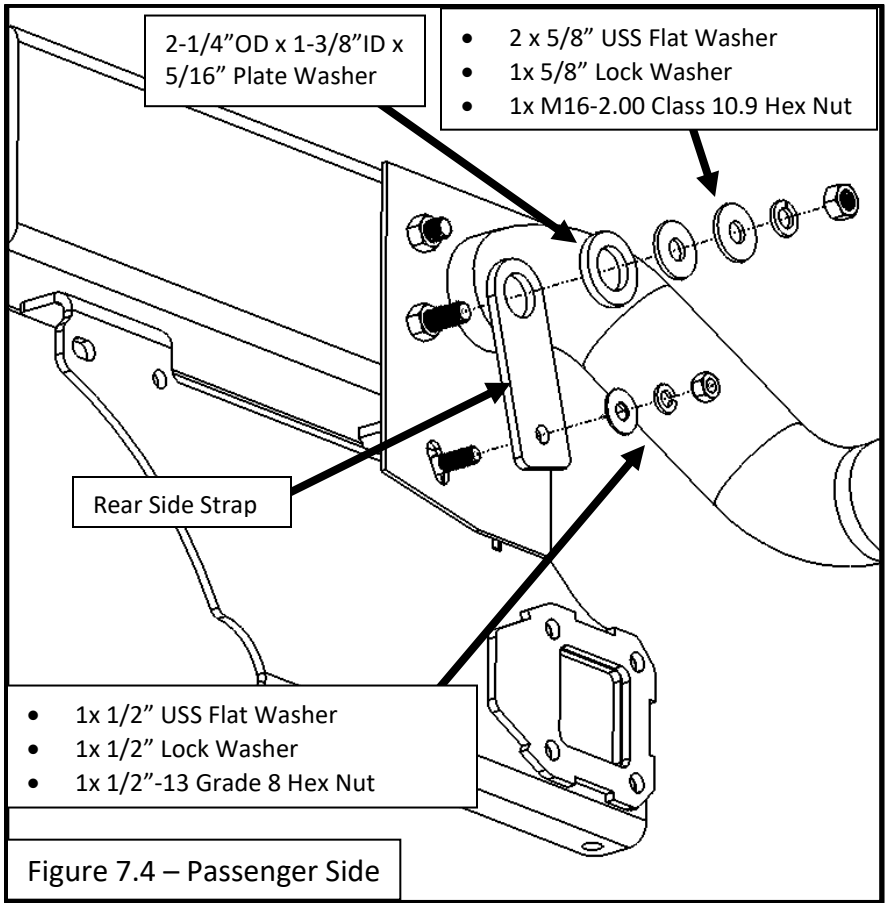

Figure 7.2 – Passenger Side

- On the inside of the Super Hitch Side Plate, place a Rear Side Strap over the 1/2" bolt threads and the factory weld nut. Secure the Rear Side Strap to the 1/2" bolt using one 1/2" USS Flat Washer, one 1/2" Lock Washer, and one 1/2"-13 Grade 8 Hex Nut.
- For 2013-2017 vehicles, secure the top of the Rear Side Strap with one 1-3/8" x 2-1/4" x 5/16" Plate Washer, one 1/2" x 2" x 3/16" Fender Washer, one 1/2" Lock Washer, and one M14-2.00 Class 10.9 Hex Nut. See figure 7.3



- For 2018 vehicles, secure the top of the Rear Side Strap with one 1-3/8" x 2-1/4" x 5/16" Plate Washer, two 5/8" USS Flat Washers, one 5/8" Lock Washer, and one M14-2.00 Class 10.9 Hex Nut. See figure 7.4



Step 8

- Insert a 1/2"x2" Grade 8 Hex Bolt with two 1/2" Flat Washers through the front hole in the side of the Super Hitch Side Plate, with the threads facing towards the fuel tank.
- On the opposite side of the plate, install a 2"x2"x5/16" Center Hole Washer over the bolt before inserting the bolt through the lower hole in the Front Side Strap. See Figure 8.1

Continued on next page.

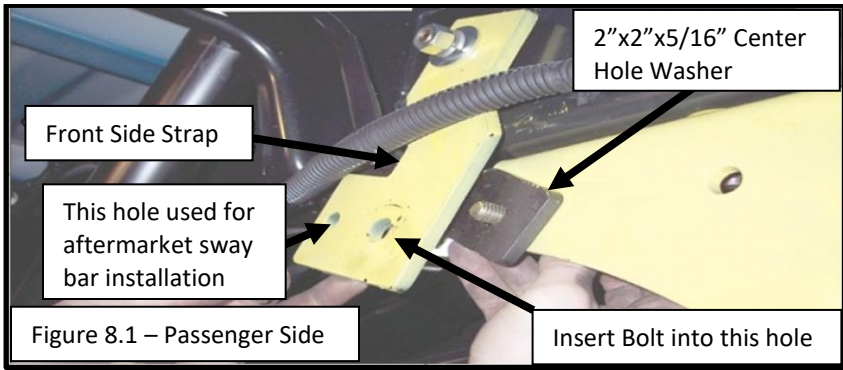

- Secure the bolt with two 1/2” Flat Washers, one 1/2” Lock Washer, and one 1/2”-13 Grade 8 Hex Nut. Leave the hardware loose.

Step 9

Repeat Step 2 through Step 8 on the driver side of the vehicle. It is important to leave all hardware as loose as possible.

Step 10 (2013-2017 vehicles only)

- For trucks of model year 2018 or newer, skip to Step 11.
- For proper spacing between the factory receiver and Super Hitch receiver on 2017 or older trucks, a spacer will need to be installed on the Super Hitch Cross Tube.
- Using a damp cloth, wipe down the top of the Super Hitch receiver tube and adjacent plates to remove any dust or debris. Dry the surfaces before proceeding.
- Remove the backing from the 2” x 8-1/4” UHMW Strip and apply it to the top of the Super Hitch Receiver as shown in figure 10.1. Press firmly on the UHMW to ensure a proper bond.

Continued on next page.

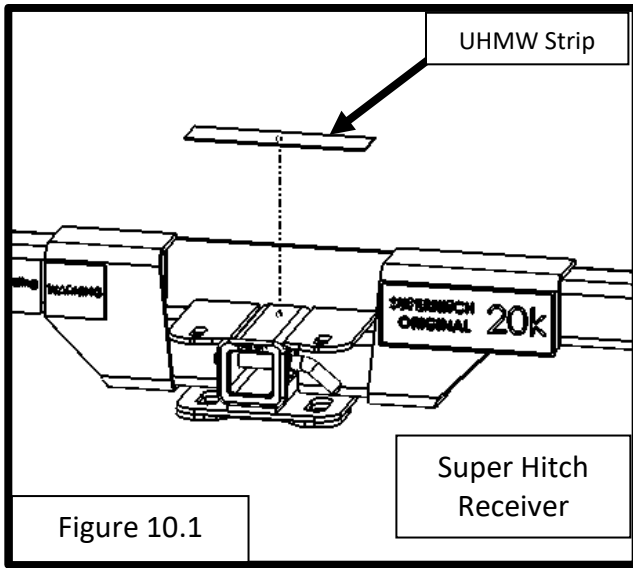

Step 11

- Slide one side of the Super Hitch Cross tube into the square hole in the Super Hitch side Plate.
- Install one 1/2" x 2" Grade 8 Hex Bolt into one of the four holes in the Super Hitch Cross Tube and through the Super Hitch Side Plate. Loosely secure the bolt with one 1/2" Lock Washer and one 1/2"-13 Grade 8 Hex Nut. See Figure 11.1.

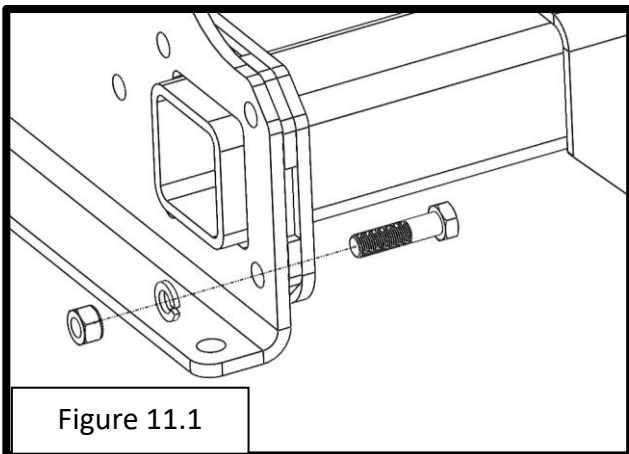

- Repeat the process for the opposite side of the cross tube, followed by the remaining six holes (three per side). It may be necessary to further loosen the side plate hardware to gain enough clearance between the side plates to install the cross tube.

Step 12

- Place one 1/2" x 2" x 3/16" Fender Washer and two 1/2" USS Flat Washers onto the threads of a 1/2"x1-1/4" Grade 5 Hex Bolt.
- For 2013-2017 vehicle only, place a 1/2" x 2" x 1/16" fender washer between the two factory chain plate holes and the two slotted holes in the Super Hitch Cross Tube. See Figure 12.1
- Insert the bolts with washers through the two large holes in the top of the factory chain plate and through the slotted holes in the Super Hitch Cross Tube.
- Secure each bolt with one 1/2"-13 Grade 5 Serrated Flange Nut. Leave the hardware loose. See Figure 12.1.

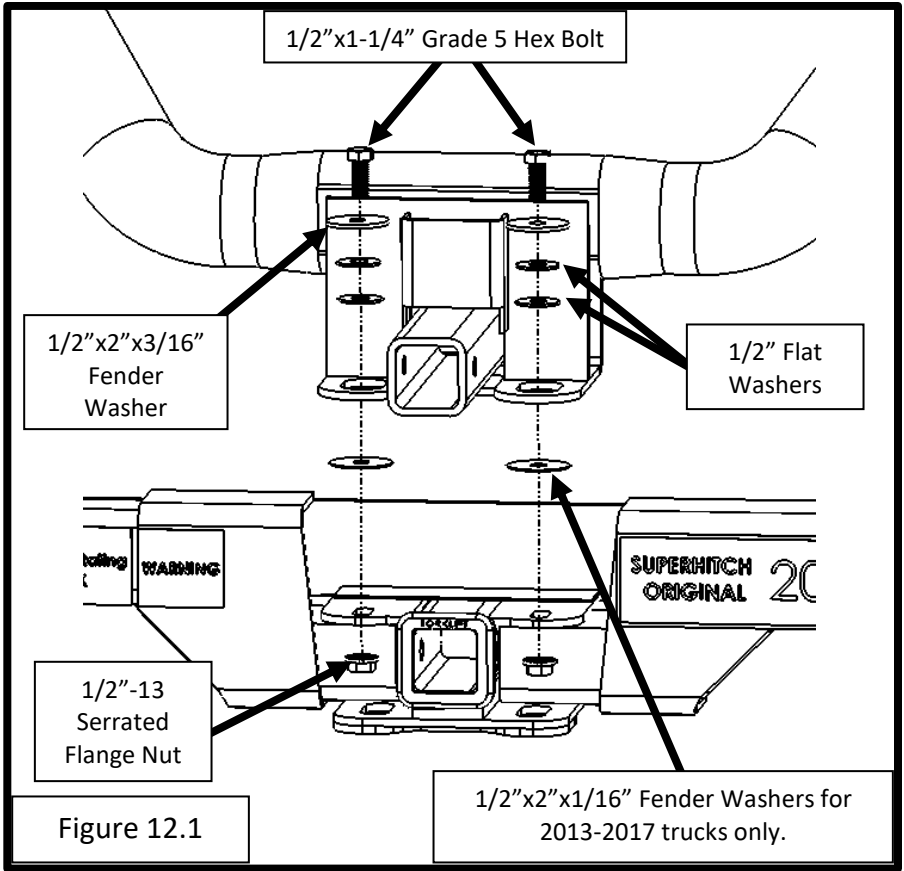

Step 13

- Align the Super Hitch Receiver and factory hitch receiver so that they are both in vertical alignment from left to right.
- Verify that the Super Hitch receiver pin hole is in vertical alignment (front to back) with the factory hitch pin hole.
- Using two 3/4" wrenches, snug the 1/2"x1-1/4" Grade 5 Hex Bolts to draw the two receivers together. Do not fully tighten.

Step 14

Torque the following hardware in sequence.

8x Super Hitch Cross Tube to Super Hitch Side Plate bolts: 75 ft-lbs (100 nm)

2x rear most Super Hitch Side Plate to truck frame bolts: 60 ft-lbs (80nm)

2x front most Super Hitch Side Plate to truck frame bolts: 60 ft-lbs (80nm)

2x Front Side Strap to Super Hitch Side Plate bolts: 60 ft-lbs (80nm)

2x Front Side Strap to truck frame bolts: 60 ft-lbs (80nm)

2x Super Hitch Cross tube to factory chain plate bolts: 60 ft-lbs (80nm)

6x factory hitch to truck frame bolts: 60 ft-lbs (80nm)

2x Rear Side Strap hardware: 60 ft-lbs (80nm)

Step 15

- Reinstall the heat shield. It will be necessary to reform the heat shield with a hammer around the bolt in Hole 1 to be able to get the mounting holes to realign.
- Reinstall the spare tire.

Installation is now complete

**THESE STEPS MAY VARY DEPENDING ON
WEIGHT DISTRIBUTION HITCH
MANUFACTURER**

**WEIGHT DISTRIBUTING
(LOAD EQUALIZING HITCH)**

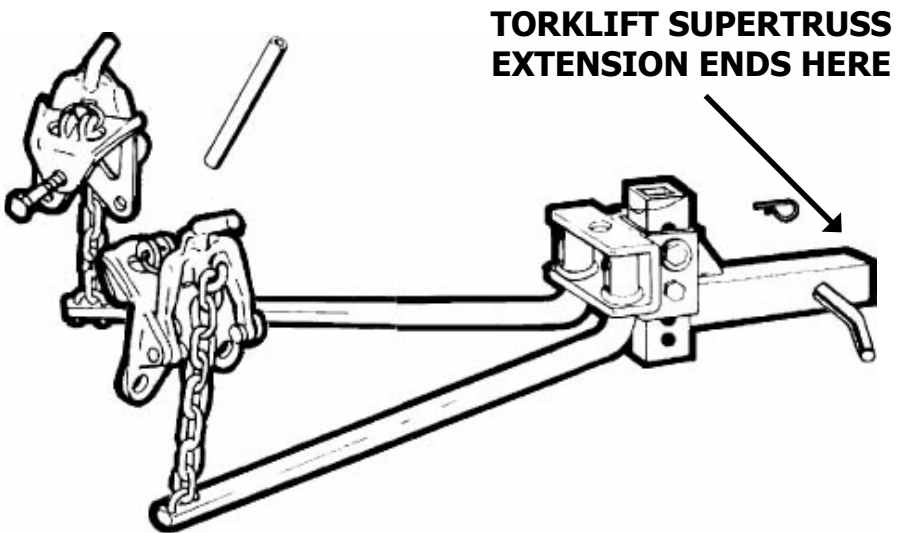

**THIS TYPE OF BALLMOUNT IS REQUIRED IN
ADDITION TO YOUR HITCH TO
OBTAIN THE MAXIMUM RATED CAPACITY.
INCORRECT INSTALLATION OF THE WEIGHT
DISTRIBUTION SYSTEM MAY RESULT IN
DAMAGE TO YOUR VEHICLE.**

WEIGHT DISTRIBUTION - CONTINUED

When towing trailers that exceed the dead weight rating on your extension it is mandatory to use a weight distributing type hitch/ball mount and related hardware (SPRING BARS, QUICK HOOKUP CLIPS ETC).

Not all weight distribution systems are rated at the same capacity. Your weight distributing ball mount and bars must be rated at least 100 lbs.(45kg) higher in regards to tongue weight, than your pre-existing tongue weight of your trailer **when fully loaded.**

It is of critical importance that your weight distribution system is not only rated high enough to match your existing tongue weight, but that you also have the system set up correctly.

We have supplied a formula to assist you in accurately determining the tongue weight load of your trailer when fully loaded. After accurately determining your tongue weight and making sure that your weight distribution system is rated high enough, your next step is to ensure the set up of the system is correct.

PLEASE READ CAREFULLY

1. The height of the ball must be determined before any assembly work can be started. To get ball height, measure trailer from ground level to top of ball coupler. Be sure trailer is parallel to ground. With your camper on your truck, fully loaded with gear and overloads adjusted, slide the weight distribution ball mount into the SuperHitch extension. Be sure the truck is on level ground. The measurement from ground to top of ball should be $1\frac{1}{2}$ "(4cm) higher than the level height of trailer top of ball measurement.

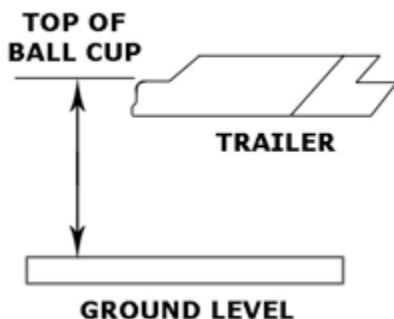

2. After ball height has been determined write down the ascertained height. EXAMPLE: Measured top of coupler height was 17"(43cm) from ground; ball height should be $18\frac{1}{2}$ "(47cm).

3. Slide the shank into the sleeve receiver, insert hitch pin and spring clip. With the ball attached to the ball mount, slide the ball mount up or down the shank until nearest dimension is obtained and the holes line up with shank. Insert the bolt in the bottom hole first (rest hitch head).

4. The rivet and 8 spacer washers are supplied in order to gain the correct downward angle of the spring bars. Insert rivet, and depending on the angle or the slope of bars that must be gained, use either 8 or the least amount of washers necessary in order to establish correct angle. The rivet and its accompanying washers are placed in the $\frac{1}{2}$ " hole between the "U" on the ball mount to acquire desired angle of spring bar. Once the spring bar angle has been determined, insert the top bolt with a flat washer, both sides, the lock washer, and nut to secure the unit in correct position, now insert the bottom bolt, use the lock washer and nut. Before tightening the bolts, lock the setscrew. (After the first day of towing, check set the screw for tightness).

See the following page for further illustrated diagrams

ILLUSTRATED DIAGRAMS

BEFORE HOOKING UP

Spring bar should hang down on a 10-13 degree angle when ball mount has been tilted back at 6-8 degree angle.

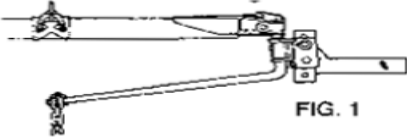

FIG. 1

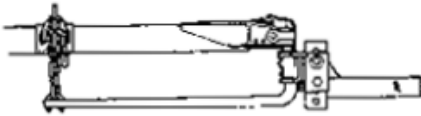

FIG. 2

AFTER HOOKING UP

Spring bar should be parallel with trailer frame, or a slight angle up or down. Slight bow or bend to bar is normal.

WRONG Readjust degree of tilt on ball mount, if you have more than 5 links of chain hanging free. The number of links should be the same on both bars.

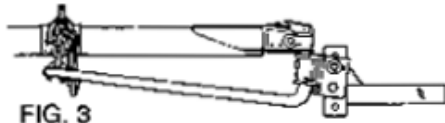
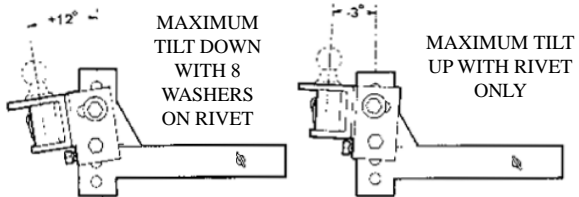
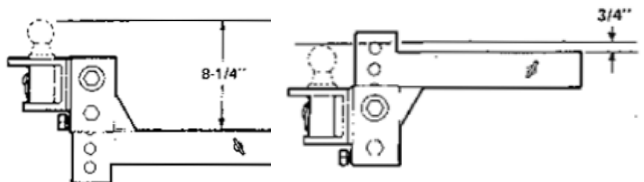

FIG. 3

EACH WASHER LOWERS CHAIN END OF SPRING BAR APPROX. 1-1/2"



BOLT-TOGETHER BALL MOUNT HAS 7-1/2" ADJUSTMENT, EACH ADJUSTMENT IS 1-1/4" EXTRA HY-LOW SHANKS AVAILABLE IF NEEDED



THESE STEPS MAY VARY DEPENDING ON WEIGHT

DISTRIBUTION HITCH MANUFACTURER

1. Put the ball mount into the sleeve and insert the 5/8" hitch pin using spring clip to lock the pin into place, hitch balls are not furnished with the hitch as there are several sizes. Normally they are supplied or may be purchased from the dealer to match the coupler of the trailer. Ball shank bushings are supplied to reduce the size of the ball hole in the hitch down to 1"(2cm) if needed.
2. Measure the towing vehicle ball height before adding load to towing vehicle. Hook the trailer to the truck. Lock on the ball. To make hooking up easier and safer - raise front of the trailer and back of the towing vehicle above level with the trailer tongue jack. This removes some of the tension by reducing the distance between the spring bar and hook-up arm.

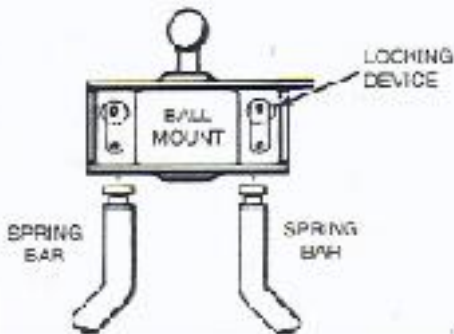

3. This step may vary depending on the manufacturer. The spring bars can be inserted into either side of the ball mount. (There is no 'right' or 'left' bar). To insert and lock spring bar in socket, hold the bar under socket and push up. The spring bar will automatically be locked into position by the

spring bar-locking device. (Check to make sure the bar is locked in by moving it up and down at the chain end.) To remove the spring bars, just pull out the locking device or swing the bar around under the bumper and it will drop free.

4. To find correct location on trailer frame for quick hook-up bracket, hold the chain straight up and down and free of twist center hook-up bracket on frame and tighten. Set the screw 1/4 turn only. **DO NOT OVERTIGHTEN.** On straight tongue trailers a poli-tongue adapter is necessary
5. You are now ready to put tension on the spring bars. When using the quick hook-up, lower the arm and slip link of chain over hook. Insert hook-up handle over the end of the quick hook-up arm. Lift and flip over center. (See fig A).

Continue onto next page for further directions

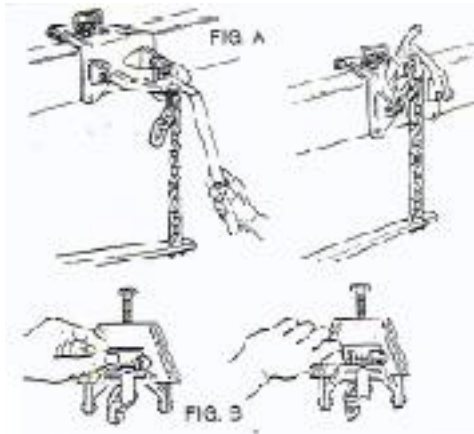

CAUTION: MAKE SURE THAT THE HOOK-UP ARM IS COMPLETELY SEATED AND THAT THE SPRING BAR IS PUSHED DIRECTLY UNDER THE HOOK-UP CHAIN HOOK.

Now install the hook-up locking clip through locking ears and over hook on hook-up arm. (See fig B)

6. Release the trailer tongue jack by adjusting the chain links up or

down; the desired load on the bars will be gained. Now lock the coupler on to the ball and raise the front of the trailer approximately 3"(8cm) above level. Now attach the chain link to the hook-up clip. It should require 50-100 lbs.(22-45kg) of force to properly tension the spring bars. Bow or bend to the spring bar is normal.

7. To release tension on the spring bars, raise the front of the trailer and the back of the towing vehicle above level (approx. 3"(8cm)) with the trailer tongue jack. Remove the locking clip from the bracket. Insert the handle over arm. Carefully lower the arm with the handle. It will require effort to bring the arm over the center and then to resist the chain tension as the arm rotates downward.

MAINTENANCE:

Use heavy lubrication such as fibre type wheel bearing grease on the hitch ball and on spring bars inside the ball mount. This is recommended every day. Also keep the hitch painted to prevent rust and check the tightness of bolts regularly. Clean out old grease and do not let it harden inside of the ball mount

IMPORTANT CONSUMER INFORMATION ON TOWING

TOWING EQUIPMENT OWNERS: Make sure all of the operators of your equipment read and understand this information before towing. Save for reference. This will help you properly select, use, and maintain your towing equipment. Refer to your owner's manuals for your tow vehicle, trailer, and other parts of your towing system. Learn the capabilities and limitations of each part. The **GROSS TRAILER WEIGHT** and **TONGUE WEIGHT** are two of the most important items to consider. **THESE WEIGHTS MUST NEVER EXCEED THE LOWEST RATING OF ANY PART OF YOUR TOWING SYSTEM.** **GROSS TRAILER WEIGHT** is the weight of the trailer plus all cargo. Measure the **GROSS TRAILER WEIGHT** with the fully loaded trailer on a level surface. The weight is the downward force exerted on the ball by the trailer coupler. Measure the **TONGUE WEIGHT** with the fully loaded trailer on a level surface. The coupler must be at its normal towing height. Use a commercial scale or a bathroom scale. Set up the bathroom scale as shown for heavy tongue weights.

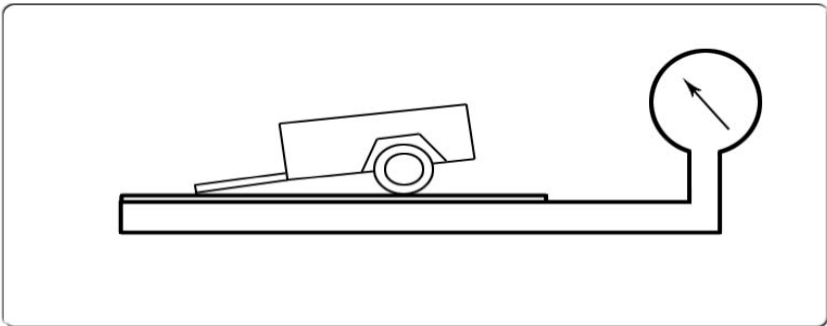

**Method for Measuring
Gross Trailer Weight**

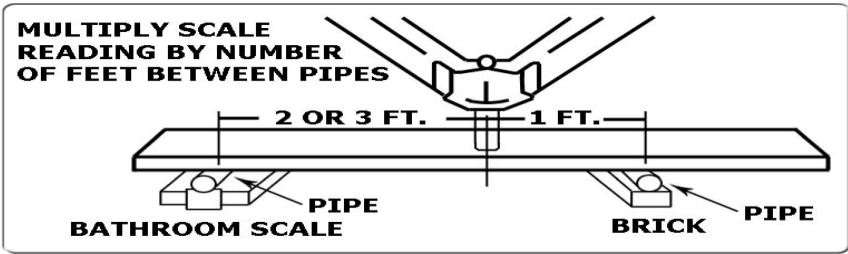

Method for Measuring Trailer Tongue Weight

YOUR TOWING EQUIPMENT

HITCH BALLS

Select by gross trailer weight rating, mounting platform thickness, hole size and coupler socket size. Platform must be at least 3/8 inch thick. Hole must not exceed threaded shank diameter by more than 1/16 inch. Use lock washer. Tighten per instructions. When tightened, shank must protrude beyond bottom of nut. Gross trailer weight rating and ball diameter are marked on Hitch balls.

TRAILER COUPLERS

The coupler socket should be smooth, clean and lightly lubricated. Tighten or adjust per coupler manufacturer's instructions.

SAFETY CHAINS

Connect safety chains properly EVERY TIME YOU TOW. Cross chains under coupler. Attach securely to the hitch or tow vehicle so they can't bounce loose. Leave only enough slack to permit full turning. Too much slack may prevent chains from maintaining control if other connections separate. Don't let chains drag on the road.

TRAILER LIGHTS, TURN SIGNALS, ELECTRIC BRAKES AND BREAK AWAY SWITCH CONNECTIONS

Make these safety-critical connections EVERY TIME YOU TOW, no matter how short the trip. Check operation, including electric brake manual control, before getting on the road.

SWAY CONTROLS

Sway controls can lessen the effects of sudden maneuvers, wind gusts and buffeting caused by other vehicles. We recommend them for trailers with large surface areas, such as travel trailers. Adjustable friction models can help control trailers with low tongue weight percentage.

OTHER USEFUL EQUIPMENT

AIR SPRINGS, AIR SHOCKS or HELPER SPRINGS are useful for some hitch applications. A TRANSMISSION COOLER may be necessary for heavy towing. Many states require TOWING MIRRORS on both sides.

TIRE INFLATION

Check often. Follow tow vehicle and trailer manufacturer's recommendations. Improper tire inflation can cause trailer sway.

NO PASSENGERS IN TRAILERS: NEVER allow people in trailers while towing, under any circumstances.

HELPFUL TOWING HINTS

TRAILER LOADING

Proper loading helps prevent sway. Place heavy object on the floor ahead of the axle. Balance the load side-to-side. Secure it to prevent shifting. Tongue weight should be 10-15 percent of gross weight for most trailers. Too low a percentage of tongue weight can cause sway. NEVER load the trailer rear heavy. LOAD THE TRAILER HEAVIER IN FRONT

DRIVING

The additional weight of a trailer affects acceleration, braking, and handling. Allow extra time for passing, stopping, and changing lanes. Severe bumps can damage your towing vehicle, hitch, and trailer. Drive slowly on rough roads. STOP AND MAKE A THOROUGH INSPECTION IF ANY PART OF YOUR TOWING SYSTEM STRIKES THE ROAD. CORRECT ANY PROBLEMS BEFORE RESUMING TRAVEL.

CHECK FOR EXCESSIVE SWAY AND ELIMINATE IT

Excessive sway can lead to loss of control. Sway motion should settle out quickly. Sway tends to increase on a downgrade. Starting slowly, increase speed in gradual steps. If sway occurs, adjust your trailer load and equipment. Repeat until the trailer is stable at high speed. Do this whenever your trailer loading changes.

IF TRAILER SUDDENLY STARTS TO SWAY

Turbulence from another vehicle, a wind gust, or a downgrade can cause sudden sway. So can a shift of the trailer's load or a trailer tire blowout. IF THE TRAILER SWAYS, IT IS THE DRIVER'S RESPONSIBILITY TO ASSESS THE SITUATION AND TAKE APPROPRIATE ACTION. Below are suggestions that may apply, depending on conditions:

DO

- Reduce your speed gradually
- Hold the steering wheel as steady as possible
- If your trailer has electric brakes, apply the brakes alone, without using the tow

vehicle's brakes.

DONT

-Don't hit your brake pedal hard unless absolutely necessary. A "jack-knife" can result.

-Don't try to steer out of the sway condition. Sudden or violent steering can make it worse.

-Don't speed up. Sway increases as you go faster.

-Don't continue towing a trailer that tends to sway. You may lose control during an emergency maneuver or if the conditions listed above occur.

Torklift International Limited Lifetime Warranty Information

322 N. Railroad Ave. Kent, WA 98032

Torklift will require proof of purchase to register, with pictures of any defective product before issuing a replacement. Torklift will not register any product without proof of purchase, which can be faxed, scanned, emailed, or mailed to the information provided below. Torklift warrants its hitches, custom hitch receivers, frame mounted tie downs, turnbuckles, and accessories (excluding wire harnesses which carry a 90 day warranty) from date of purchase against defects in material and

workmanship under normal use and service for the ownership life of the original consumer purchaser. All plastic, rubber, and/ or electrical components maintain a warranty of up to one year from the date of the purchase. **ALL COMMERCIAL APPLICATIONS ARE WARRANTED FOR A PERIOD OF 90 DAYS FROM THE DATE OF INSTALLATION/SERVICE.** Torklift will replace **FREE OF CHARGE** any part which proves defective in material or workmanship when presented to Torklift, **TRANSPORTATION CHARGES PREPAID** by purchaser, at the address above. **THIS WARRANTY IS LIMITED TO DEFECTIVE PARTS REPLACEMENT ONLY. LABOR CHARGES AND/OR DAMAGE INCURRED IN INSTALLATION OR REPLACEMENT, AS WELL AS INCIDENTAL AND CONSEQUENTIAL DAMAGES CONNECTED THEREWITH ARE EXCLUDED.** This warranty does not include the finish or paint on our products. Rusting, cracking or peeling of the finish is also excluded. Some states do not allow the exclusion or limitation of incidental or consequential damages, so the above limitation or exclusion may not apply to you. Any damage to Torklift products as a result of misuse, abuse, neglect, accident, improper installation or any use violative of instructions furnished by Torklift or **WHEN USED IN ANY COMMERCIAL APPLICATION WILL VOID THE WARRANTY.** This warranty gives you specific legal rights, and you may also have rights which vary from state to state. With warranty service, you may be able to go to a small claims court, a state court or a federal district court.

Dear Valued Customer,

Thank you for making TorkLift your choice for truck, camper packages and accessories for your vehicle. By choosing TorkLift products, you have chosen a company that has been serving the RV industry for nearly 40 years and whose name has become synonymous with strength, quality and advanced design and installation.

Please take a few moments of your time to complete the Product Registration Warranty Card on the next page. When registering your newly purchased TorkLift products, you can be assured that your contact information is secure and that you and your product are getting the attention and respect that you deserve.

Thank you again for choosing TorkLift quality products.

**Register for your lifetime warranty and receive a free
Torklift International gift.**

To Fax: Send copies of the questionnaire, warranty card and receipt to
253-854-8003

To E-mail: Send copies of the questionnaire, warranty card and receipt to
warranty@torklift.com

To Mail: Send to Torklift International 322 N. Railroad Ave Kent, WA 98032

OFFICIAL WARRANTY REGISTRATION CARD

PLEASE FILL OUT THIS FORM COMPLETELY AND RETURN TO TORKLIFT WITHIN

30 DAYS OF PURCHASE ACCOMPANIED BY A COPY OF YOUR ORIGINAL RECEIPT



1. PART(S) PURCHASED

TODAY'S DATE: _____

PART #: _____ PART #: _____
PART #: _____ PART #: _____
PART #: _____ PART #: _____

2. PURCHASER INFORMATION

NAME: _____
ADDRESS: _____

CITY: _____ STATE: _____ ZIP / POSTAL CODE: _____
PHONE: (____) _____ - _____ EMAIL: _____

3. TRUCK INFORMATION

YEAR: _____ MAKE: _____
MODEL: _____ BED LENGTH: _____

4. CAMPER INFORMATION

YEAR: _____ MAKE: _____ MODEL: _____

5. DEALER INFORMATION

PURCHASED FROM: _____
ADDRESS: _____

CITY: _____ STATE: _____ ZIP / POSTAL: _____
INSTALLED BY: _____ OWNER ABOVE DEALER ANOTHER DEALER

IF ANOTHER DEALER, WHO: _____