

TORKLIFT

INTERNATIONAL

**OVER 40 YEARS OF INNOVATION, QUALITY, SAFETY.
IMPORTANT OWNER-OPERATOR INSTALLATION
INSTRUCTIONS**

D2134 - Tie Down Kit

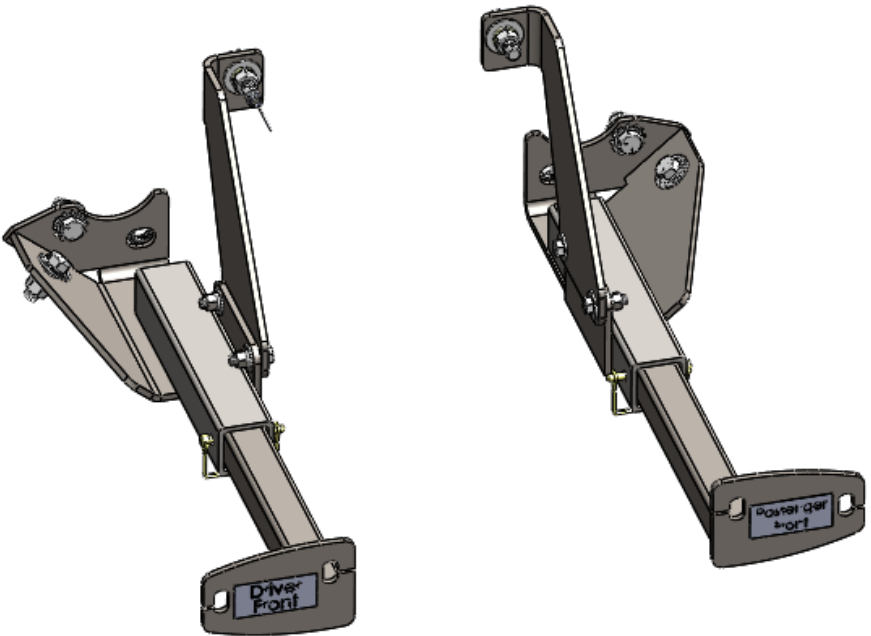

**Version 1 BY: CW 4-19-2017
TECH SUPPORT (800) 246-8132**

**AFTER INSTALL, PLEASE GIVE
THIS BOOKLET TO YOUR CUSTOMER**

Warnings

Truck Bed and Camper Protection







Torklift **does not** recommend installing your camper on top of a plastic bed liner (or other compressible material such as foam). These materials can act as a spring, causing increased vertical truck camper movement independent of the vehicle. Plastic bed liners can slide on the truck bed surface, and the truck camper can slide on top of the bed liner. Using a plastic bed liner or similar compressible material will void your warranty and may additionally cause truck bed and/or camper damage.



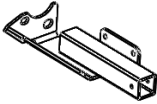
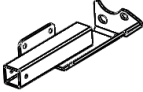

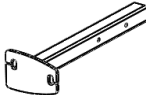
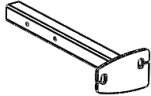
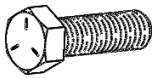
Minor movement or settling can occur in some incidental harsh driving conditions (on or off-road). A rubber bed mat is recommended to protect the truck bed and camper, but is not a requirement to maintain the Torklift legendary lifetime warranty.

Suspension

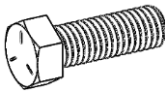
To significantly reduce body roll, sag and sway Torklift strongly recommends the StableLoad. Torklift International StableLoads improve safety, handling, and to help level your truck. More information can be found at (www.Torklift.com/stableload).

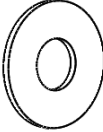
If your truck is additionally equipped with suspension air bags Torklift cautions against over pressurization as this may lead to unsafe vehicle handling characteristics. We have found that airbags used in conjunction with StableLoads have allowed operators to lower air bag pressure by 50% or more. Only pressurize suspension air bags enough to level the truck.

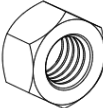
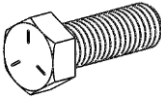
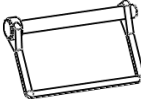
<u>Parts Inventory</u>			
Item Image	Item Description	Part #	Qty
	Driver Side Tie Down Receiver	D2134-W1-D	1
	Passenger Side Tie Down Receiver	D2134-W1-P	1
	Driver Side Bolt-on Gusset	D2134-P3-D	1
	Passenger Side Bolt-on Gusset	D2134-P3-P	1
	17-7/8" Straight Insert – Right Offset	TD-INS-17.875-STR-RO-ST	1
	17-7/8" Straight Insert – Left Offset	TD-INS-17.875-STR-LO-ST	1
	3/8"-16 x 1-1/4" Grade 5 Hex Bolt	4627	4
	3/8" USS Flat Washer	6001	8
	3/8" Split Lock Washer	6003	4
	3/8"-16 – Grade 5 Hex Nut	3306	4
	1/2" Internal External Lock Washer	4566	6
	1/2"-13 x 1-1/2" Grade 5 Hex Bolt	3443	4

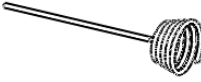
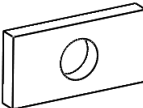
<u>Parts Inventory</u>			
Item Image	Item Description	Part #	Qty
	1/2" USS Flat Washer	6039	8
	1/2" Split Lock Washer	9302	6
	1/2"-13 Grade 5 Hex Nut	6022	6
	1/2"-13 x 2" Grade 5 Hex Bolt	3442	2
	1/4" x 2-1/4" Bail Pin	1452	2
	M16-2.00 – Jam Nut	13179	2
	M16 – Internal Lock Washer	13084	2
	1/2" Bolt Fisher	3818	1
	1/2" x 1" x 2" Plate Washer	10859	4
	Front Driver Insert Sticker	3844	1
	Front Passenger Insert Sticker	3845	1

Step 1

Locate the lower control arm frame mount on the driver side of the vehicle (Figure 1.1).

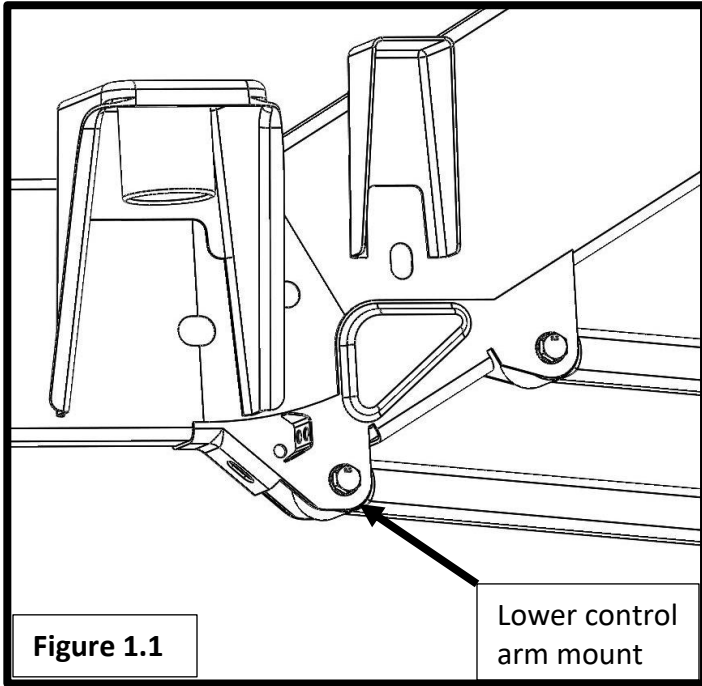

Remove the nut from the lower control arm mounting bolt (Figure 1.2).

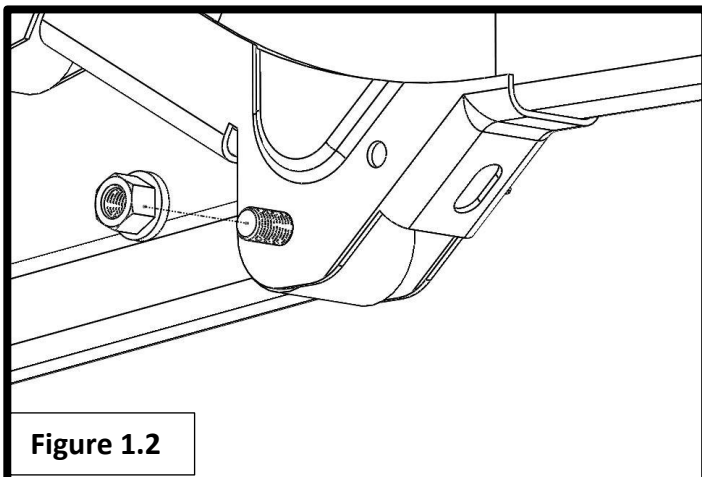

Step 2

Place a 1/2" Internal External Lock Washer onto a 1/2"-13 x 1-1/2" Grade 5 Hex Bolt.

Place the bolt inside the front portion of the lower control arm mount, then insert it through the hole just forward of the lower control arm (Figure 2)

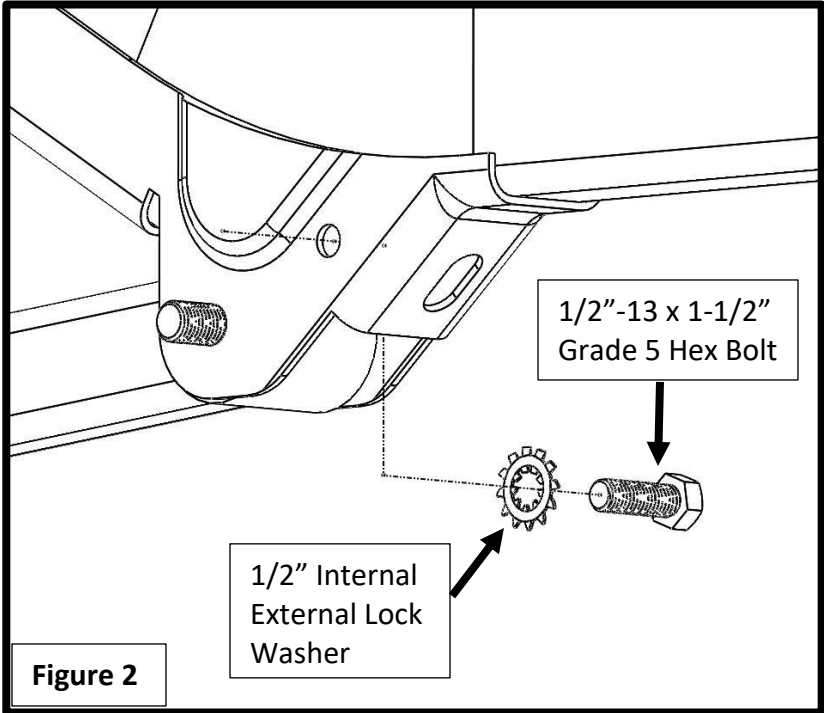

The threads should now be facing towards the fuel tank.

Step 3

Install the Driver Side Tie Down Receiver over the lower control arm mounting bolt and the previously installed 1/2"-13 x 1-1/2" Grade 5 Hex Bolt (Figure 3)

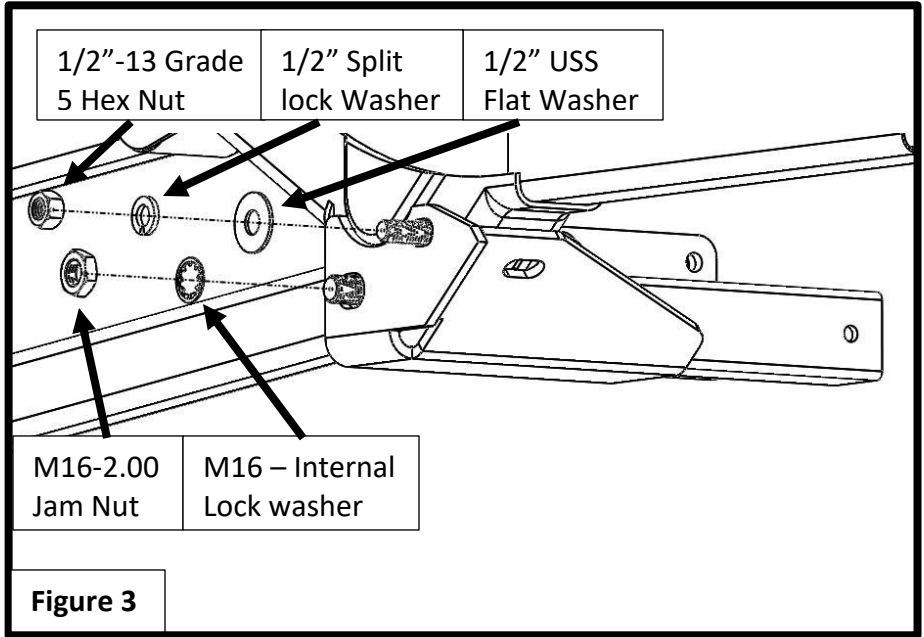

Loosely install a M16 – Internal Lock washer and a M16-2.00 Jam Nut onto the remaining threads of the lower control arm mounting bolt.

Loosely install a 1/2" USS Flat Washer, a 1/2" Split lock Washer, and a 1/2"-13 Grade 5 Hex Nut onto the previously installed 1/2"-13 x 1-1/2" Grade 5 Hex Bolt.

Step 4

Insert the coiled end of the 1/2" bolt fisher through the Driver Side Tie Down Receiver and lower control arm mount as shown in figure 4.1

Guide the coiled end of the bolt fisher over the control arm until it is accessible from the rear of the Driver Side Tie Down Receiver.

Place one 1/2" Internal External Lock Washer followed by one 1/2" USS Flat Washer onto the threads of a 1/2"-13 x 1-1/2" Grade 5 Hex Bolt.

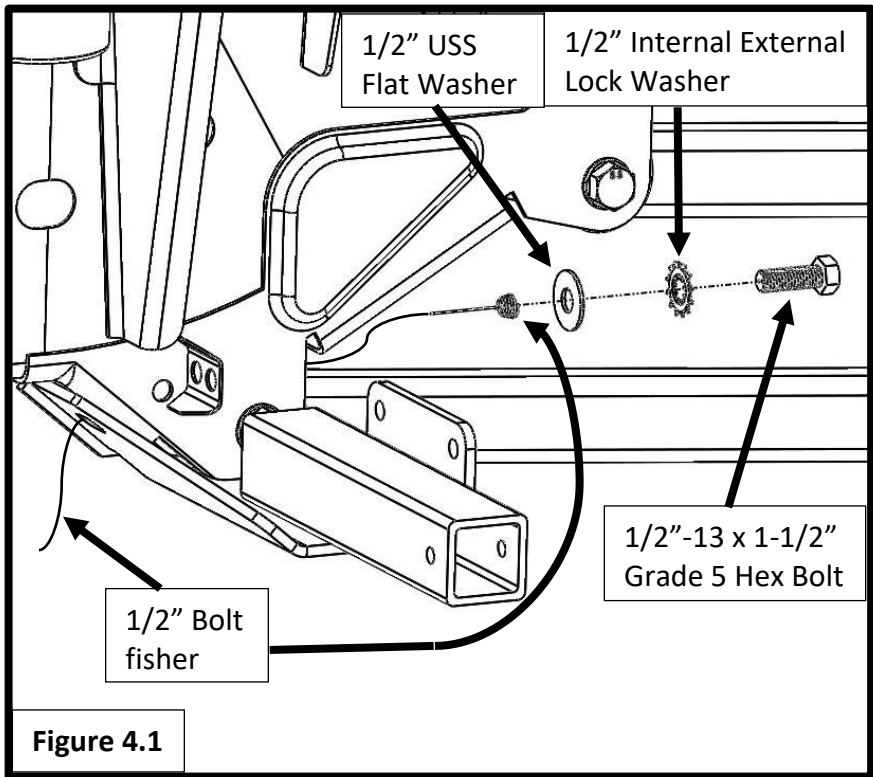

Step 4 Cont.

Attach the bolt to the bolt fisher. Using the wire end of the bolt fisher, pull the bolt and hardware over the top of the lower control arm and through frame and tie down.

Remove the bolt fisher, then loosely secure the bolt with one 1/2" USS Flat Washer, one 1/2" Split Lock Washer, and one 1/2"-13 Grade 5 Hex Nut. See figure 4.2

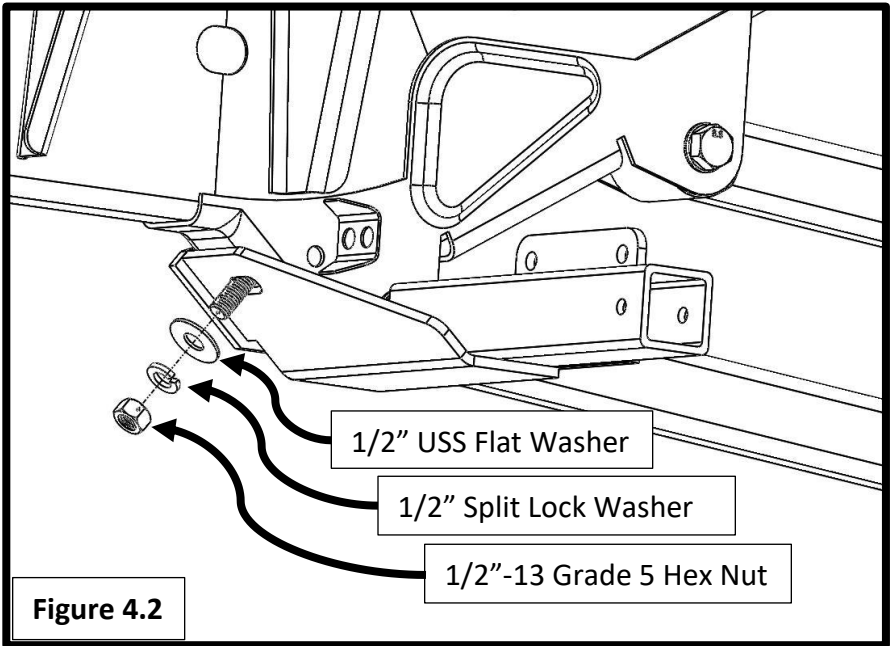

Step 5

Place one 1/2" Internal External Lock Washer followed by one 1/2" x 1" x 2" Plate Washer onto the threads of a 1/2"-13 x 2" Grade 5 Hex Bolt.

Attach the bolt to the 1/2" bolt fisher, then insert the hardware (bolt first) into the frame as shown in figure 5.1

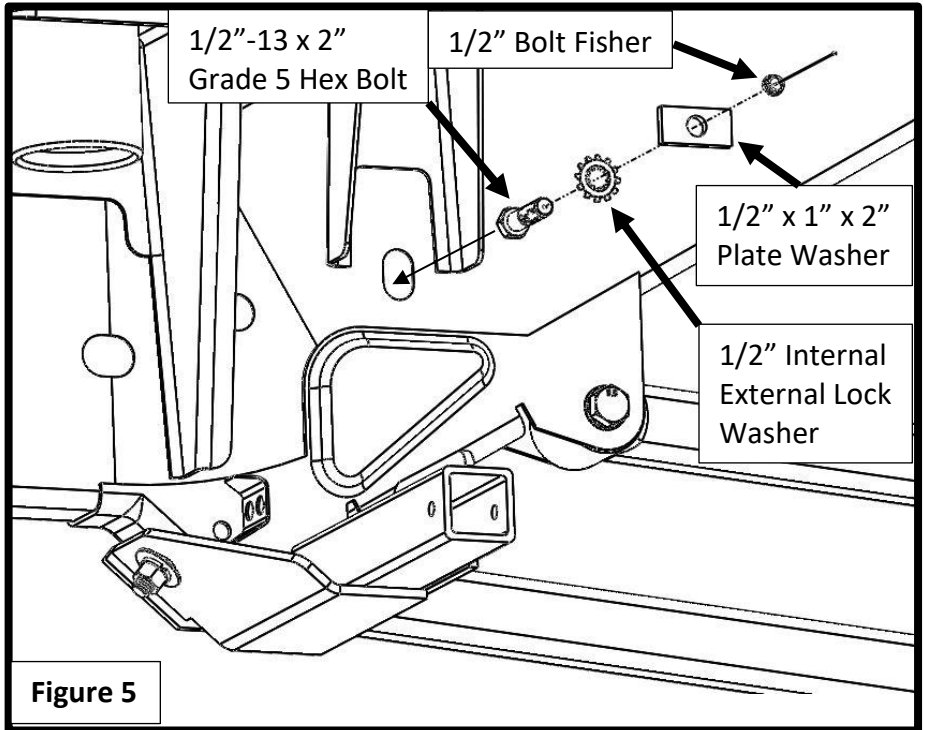

Make sure to leave the wire end of the bolt fisher outside of the frame.

Step 6

Slide the wire end of the bolt fisher through an additional 1/2" x 1" x 2" Plate Washer, and then through the Driver Side Bolt-on Gusset. Place the gusset up against the frame.

Using the 1/2" Bolt Fisher, pull the threaded end of the 1/2"-13 x 2" Grade 5 Bolt back out of the frame and through the Driver Side Bolt-on Gusset.

Carefully remove the bolt fisher, then loosely secure the bolt with one 1/2" USS Flat Washer, one 1/2" Split Lock Washer, and one 1/2"-13 Grade 5 Hex Nut (Figure 6).

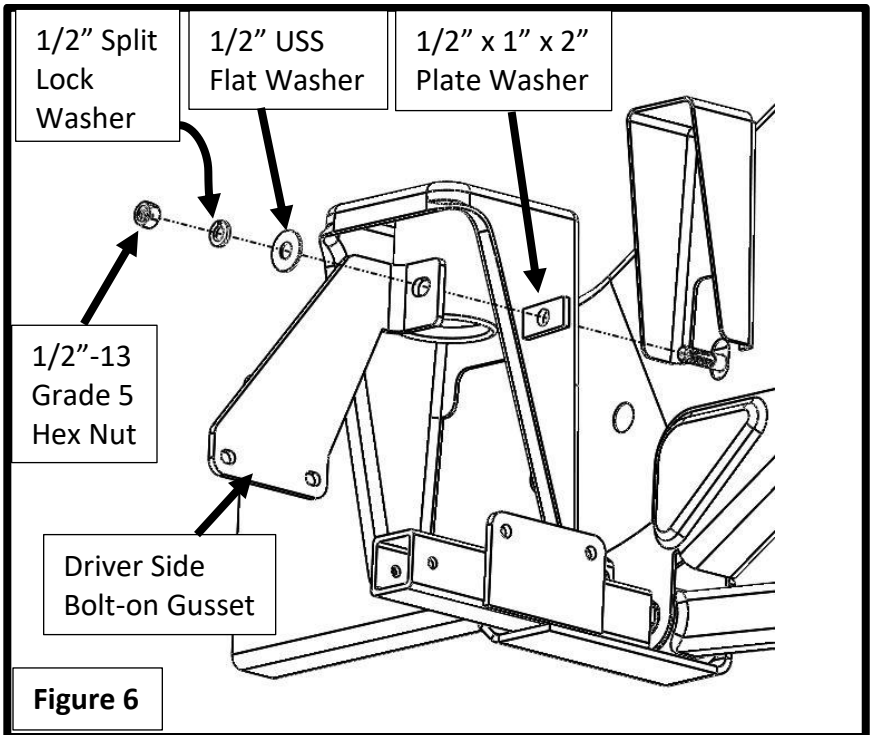

Step 7

Insert one 3/8"-16 x 1-1/4" Grade 5 Hex Bolt with one 3/8" USS Flat Washer into each of the lower holes of the Driver Side Bolt-on Gusset and out through the two 3/8" holes in the Driver Side Tie Down Receiver (Figure 7).

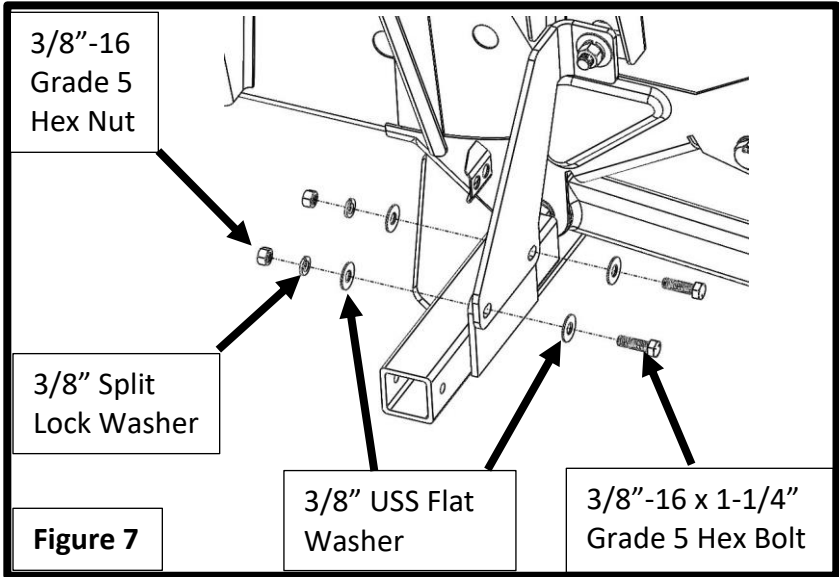

Secure each bolt with one 3/8" USS Flat Washer, one 3/8" Split Lock Washer, and one 3/8"-16 Grade 5 Hex Nut.

Step 8

Torque the hardware in the following order:

- | | |
|--|-------------------|
| 1. M16 Jam nut/Lower control arm bolt | 55 ft-lbs (75 Nm) |
| 2. 1/2" Hardware in lower control arm mount | 55 ft-lbs(75 Nm) |
| 3. 1/2" Hardware in Driver Side Bolt-on Gusset | 55 ft-lbs(75 Nm) |
| 4. 3/8" Hardware | 30 ft-lbs (41 Nm) |

Step 9

Repeat the installation process on the passenger side of the vehicle.

TIEDOWN INSERT INSTALLATION

INSTRUCTIONS

On one end of each of your tie down inserts is a triangular plate referred to by Torklift as a bullet plate. In most cases, the tie down inserts should be installed with the shorter side of the bullet plate facing away from each other (The shorter side of the front insert should point to the front of the truck and the shorter side of the rear insert should point towards the rear of the truck).



DRIVERS SIDE FRONT



DRIVERS SIDE REAR

Once installed, attach the TorkLift directional stickers to the face of the bullet plate on the insert as a reminder.

IMPORTANT NOTE: *Your tie down inserts are designed to have clearance inside of the receiver. This is to account for road debris, as well as aid in installation and removal. Some rattle may be expected if the inserts are left installed while not under load from the camper.*

Torklift International Limited Lifetime Warranty Information

322 Railroad Ave North, Kent, WA 98032

Torklift will require proof of purchase to register, with pictures of any defective product before issuing a replacement. Torklift will not register any product without proof of purchase, which can be faxed, scanned, emailed, or mailed to the information provided below. Torklift warrants its hitches, custom hitch receivers, frame mounted tie downs, turnbuckles, and accessories (excluding wire harnesses which carry a 90 day warranty) from date of purchase against defects in material and workmanship under normal use and service for the ownership life of the original consumer purchaser. All plastic, rubber, and/ or electrical components maintain a warranty of up to one year from the date of the purchase. **ALL COMMERCIAL APPLICATIONS ARE WARRANTED FOR A PERIOD OF 90 DAYS FROM THE DATE OF INSTALLATION/SERVICE.** Torklift will replace **FREE OF CHARGE** any part which proves defective in material or workmanship when presented to Torklift, **TRANSPORTATION CHARGES PREPAID** by purchaser, at the address above. **THIS WARRANTY IS LIMITED TO DEFECTIVE PARTS REPLACEMENT ONLY. LABOR CHARGES AND/OR DAMAGE INCURRED IN INSTALLATION OR REPLACEMENT, AS WELL AS INCIDENTAL AND CONSEQUENTIAL DAMAGES CONNECTED THEREWITH ARE EXCLUDED.** This warranty does not include the finish or paint on our products. Rusting, cracking or peeling of the finish is also excluded. Some states do not allow the exclusion or limitation of incidental or consequential damages, so the above limitation or exclusion may not apply to you. Any damage to Torklift products as a result of misuse, abuse, neglect, accident, improper installation or any use violative of instructions furnished by Torklift or **WHEN USED IN ANY COMMERCIAL APPLICATION WILL VOID THE WARRANTY.** This warranty gives you specific legal rights, and you may also have rights which vary from state to state. With warranty service, you may be able to go to a small claims court, a state court or a federal district court.



INTERNATIONAL

**322 Railroad Ave North, Kent, WA
98032**

**Phone (800) 246-8132 Fax (253) 854-
8003**

Or visit our website: www.TorkLift.com

Dear Valued Customer,

Thank you for making TorkLift your choice for truck, camper packages and accessories for your vehicle. By choosing TorkLift products, you have chosen a company that has been serving the RV industry for nearly 40 years and whose name has become synonymous with strength, quality and advanced design and installation.

Please take a few moments of your time to complete the Product Registration Warranty Card on the next page. When registering your newly purchased TorkLift products, you can be assured that your contact information is secure and that you and your product are getting the attention and respect that you deserve.

Thank you again for choosing TorkLift quality products.

**Register for your lifetime warranty and receive a free
Torklift International gift.**

To Fax: Send copies of the questionnaire, warranty card and receipt to
253-854-8003

To E-mail: Send copies of the questionnaire, warranty card and receipt to
warranty@torklift.com



To Mail: Send to Torklift International 1901 Fryar Ave Sumner, Wa 98390

OFFICIAL WARRANTY REGISTRATION CARD

322 Railroad Ave North, Kent, WA 98032

PLEASE FILL OUT THIS FORM COMPLETELY AND RETURN TO TORKLIFT WITHIN
30 DAYS OF PURCHASE ACCOMPANIED BY A COPY OF YOUR ORIGINAL RECEIPT

1. PART(S) PURCHASED

TODAY'S DATE: _____

PART#: _____ PART#: _____
PART#: _____ PART#: _____
PART#: _____ PART#: _____

2. PURCHASER INFORMATION

NAME: _____
ADDRESS: _____

CITY: _____ STATE: _____ ZIP / POSTAL CODE: _____
PHONE: (____) _____ - _____ EMAIL: _____

3. TRUCK INFORMATION

YEAR: _____ MAKE: _____
MODEL: _____ BED LENGTH: _____

4. CAMPER INFORMATION

YEAR: _____ MAKE: _____ MODEL: _____

5. DEALER INFORMATION

PURCHASED FROM: _____
ADDRESS: _____

CITY: _____ STATE: _____ ZIP / POSTAL: _____
INSTALLED BY: _____ OWNER ABOVE DEALER ANOTHER DEALER

IF ANOTHER DEALER, WHO: _____