

# **TORKLIFT** **INTERNATIONAL**

**OVER 35 YEARS OF INNOVATION, QUALITY, SAFETY.  
IMPORTANT OWNER-OPERATOR INSTALLATION INSTRUCTIONS**

## **Part # F1002-30**

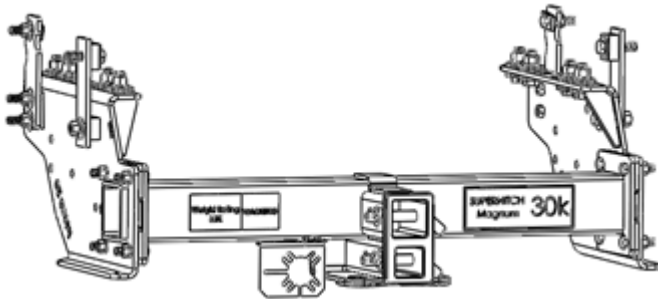

REVISED v6 BY: CW 12-3-2019

**TECH SUPPORT (800) 246-8132**

**AFTER INSTALL, PLEASE GIVE  
THIS BOOKLET TO YOUR CUSTOMER**

# Hitch Weight Capacity

## **Weight Carry**

20,000 lbs maximum pull weight  
2,500 lbs maximum tongue weight







## **Weight Distribution**



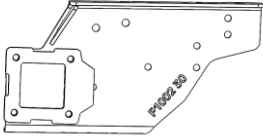
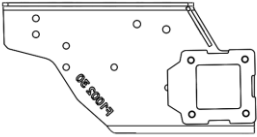
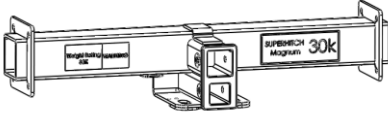

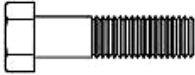



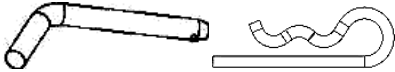

30,000 lbs maximum pull weight  
3,000 lbs maximum tongue weight.



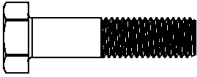
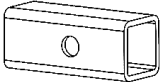

## **Warning**

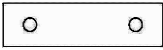
Do not exceed the factory weight ratings of  
your vehicle

## F1002-30 Parts List

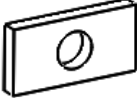
<p><b>Driver Side Plate</b></p>		<p><b>1</b></p>	<p><b>F1002-30-W1-D</b></p>
<p><b>Passenger Side Plate</b></p>		<p><b>1</b></p>	<p><b>F1002-30-W1-P</b></p>
<p><b>Cross Tube</b></p>		<p><b>1</b></p>	<p><b>SH-4.00-38.00-A1</b></p>
<p><b>3/4" Spacer Plates</b></p>		<p><b>4</b></p>	<p><b>TL-HW-PW-P17</b></p>
<p><b>1/2"-13 x 2" Grade 8 Hex Bolts</b></p>		<p><b>14</b></p>	<p><b>3659</b></p>
<p><b>1/4" Lock washers</b></p>		<p><b>2</b></p>	<p><b>3457</b></p>
<p><b>1/4"-20 Nut</b></p>		<p><b>2</b></p>	<p><b>3458</b></p>
<p><b>1/4"-20 x 1" Hex Bolt</b></p>		<p><b>2</b></p>	<p><b>3454</b></p>
<p><b>#12 x 3/4" Self-Tapping Screws</b></p>		<p><b>2</b></p>	<p><b>3313</b></p>

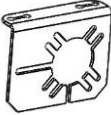
<p><b>5/8" Hitch Pin and Clip</b></p>		<p><b>2</b></p>	<p><b>3703</b></p>
<p><b>9/16" USS Flat Washer</b></p>		<p><b>8</b></p>	<p><b>6042</b></p>
<p><b>9/16" -12 Grade 8 Nuts</b></p>		<p><b>2</b></p>	<p><b>13087</b></p>
<p><b>1/2" USS Flat Washer</b></p>		<p><b>10</b></p>	<p><b>6039</b></p>
<p><b>M14-2.00 x 60 MM Hex Bolts</b></p>		<p><b>2</b></p>	<p><b>9867</b></p>
<p><b>Magnum Receiver Adapter</b></p>		<p><b>1</b></p>	<p><b>9580</b></p>
<p><b>5/8" USS Flat Washer</b></p>		<p><b>32</b></p>	<p><b>6089</b></p>
<p><b>5/8" Lock Washers</b></p>		<p><b>8</b></p>	<p><b>6023</b></p>
<p><b>5/8" -11 GR8 Nuts</b></p>		<p><b>8</b></p>	<p><b>9842</b></p>
<p><b>5/8"-11 x 2" GR8 Bolts</b></p>		<p><b>8</b></p>	<p><b>9846</b></p>
<p><b>Rear Side Strap</b></p>		<p><b>2</b></p>	<p><b>SH-SS-P2</b></p>
<p><b>Front Side Strap</b></p>		<p><b>2</b></p>	<p><b>SH-SS-P8</b></p>

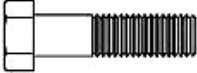
2-1/2" X 2-1/2" X 1/4" Spacers		2	TL-HW-PW-P20
1" x 2" Plate Washers		2	10859
1/2" Lock Washers		14	9302
1/2"-13 Grade 8 Hex Nuts		14	1751
Plug Bracket		1	16016
M14-2.00 x 40mm Hex Bolt		2	10209
9/16" Lock Washer		2	4071
9/16"-12 x 2-1/4" Grade 8 Hex Bolts		2	9843

**WARNING:** Do not lubricate threads. Bolt failure may occur due to over tightening. Do **not** drill on this hitch.

**Note:** This product is not recommended for use on a 1/2-ton vehicle.

# Installation Instructions

## Step 1

Start by loosening the spare tire so it can be pushed forward if necessary. Remove existing receiver hitch (if equipped).

- If your truck is equipped with a factory hitch, proceed to **Step 2a**
- If your truck is not equipped with a factory hitch, proceed to **Step 2b**

## Step 2a

Hold the driver side Super Hitch Side Plate up to the truck frame, reinstall the rearmost nut plate back onto the frame and thread one factory bolt into the rearmost hole of the plate. This will hold the plate in place, as seen in **Photo 2.1**.



**Photo 2.1**

## Step 3a

Hold the forward most nut plate in position, and reinstall the other three factory bolts, as seen in **Photo 3.1**. Leave the bolts loose.

Repeat Steps 2 and 3 for the passenger side **Super Hitch Side Plate**



**Photo 3.1**

Proceed to **Step 4**

## Step 2b

Hold the driver side Super Hitch Side Plate up to the truck frame, Install one **5/8"-11 x 2" Grade 8 Bolt** and two **5/8" Flat Washers** down through the frame and into the rearmost hole in the **Super Hitch Side Plate**.

## Step 3b

Secure the bottom side of the bolt with two **5/8" Flat Washers**, one **5/8" Lock Washer**, and one **5/8"-11 Nut**. Leave loose at this time. Repeat this process for the three remaining holes between the **Super Hitch Side Plate** and the vehicle frame.

Proceed to **Step 4**.

## Step 4

Place one end of the **Super Hitch Cross Tube** into the square hole in one of the **Super Hitch Side Plates**. Install one **1/2"-13 x 2" Bolt** into one of the lower holes in the cross tube flange and out through the **Super Hitch Side Plate**.

## Step 5

Place the other end of the **Super Hitch Cross Tube** into the square hole in the other **Super Hitch Side Plate**.

Lightly tighten the bolts holding the **Super Hitch Side Plates** to the vehicle frame. This will help to keep the **Super Hitch Cross Tube** from coming out of the **Super Hitch Side Plates**.

## Step 6

Install the remaining **1/2"-13 x 2" Bolts** into the holes in the cross tube flanges and out through the super hitch side plates.

Secure each bolt with one **1/2" Lock Washer** and one **1/2"-13 Grade 8 Hex Nut**

## Step 7.

From the inside of the truck frame, directly above the forward most hole in the driver side **Super Hitch Side Plate**, Insert a **1/2"-13 x 2" Grade 8 Hex Bolt** with one **1" x 2" Plate Washer** through the hole in the truck frame. See **Photo 7.1**



Photo 7.1

## Step 8

Place a **Front Side Strap** over the upper bolt (**See Photo 8.1**) and secure with one **1/2" USS Flat Washer**, one **1/2" Lock Washer** and one **1/2"-13 Hex Nut**. Hand tighten the upper bolt. Align the **2-1/2" X 2-1/2" X 1/4" Spacer** between the **Front Side Strap** and **Super Hitch Side Plate** (See photo 6.1). Through each of the holes, place one **1/2"-13 x 2"** Grade 8 Bolt with one **1/2" USS Flat Washer**. Secure the other side of the bolts with one **1/2" USS Flat Washer**, one **1/2" Lock Washer**, and one **1/2"-13 Grade 8 Nut**.



**Photo 8.1**

## Step 9

Working on only the driver side, remove the two factory bolts attaching the bumper bracket to the rear of the vehicle frame. See **Photo 9.1**



**Photo 9.1**

### **Step 10**

From the inside of the frame, place one **M14 - 2.00 x 40mm Bolt** with one **9/16" USS Flat Washer** through the forward most hole in the bumper bracket. Secure the other side of the bolt with the factory nut.

From the inside of the frame, place one **M14 - 2.00 x 60mm Bolt** with one **9/16" USS Flat Washer** through the rearward most hole of the bumper bracket. From the outside of the frame, place one **3/4" Spacer** onto the bolt, followed by one end of **Rear Side Strap**. Secure with the factory nut. Leave loose.

### **Step 11**

Slide another **3/4" Spacer** between the lower portion of the **Rear Side Strap** and the **Super Hitch Side Plate**.

Install a **9/16" x 2-1/4" Grade 8 Bolt** and one **9/16" USS Flat Washer** from the inside of the **Super Hitch Side Plate** out through the **3/4" Spacer** and **Rear Side Strap**. Secure with one **9/16" USS Flat Washer**, one **9/16" Lock Washer**, and one **9/16"-12 Grade 8 Hex Nut**. See **Photos 11.1 and 11.2**

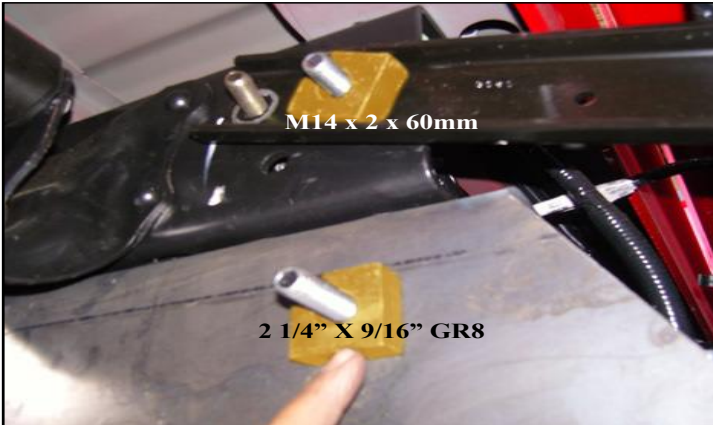

**Photo 11.1**



**Photo 11.2**

## Step 12

Repeat steps 5 through 8 for the passenger side.

## Step 13

For pre-2008 vehicles, attach the Plug Bracket onto the tab welded to the Super Hitch Cross Tube. Use the supplied **1/4"-20 x 1" Hex Bolt**, **1/4" Lock Washers**, and the **1/4"-20 Hex Nuts**. Tighten until snug.

Secure the factory plug to the plug bracket using the supplied **#12 x 3/4" Self Tapping Screws**.

## Step 13

Torque all Fasteners to the following ratings:

- Side Plate to vehicle frame bolts: 100 ft-lbs (135 nm)
- Super Hitch Cross Tube to Super Hitch Side Plates: 75 ft-lbs (101 nm)
- 14mm Bumper Bracket bolts: 100 ft-lbs (135 nm)
- Remaining 1/2" and 9/16" Side Strap to Super Hitch Side Plate bolts: 75 ft-lbs (101 nm)

## Step 14

For Vehicles prior to 2008, install the included plug bracket to the tab welded to the Super Hitch Cross tube using one 1/4"-20 x 1" Hex Bolt, one 1/4" Lock washer and one 1/4"-20 Hex nut per hole.

Attach the factory plug to the Plug Bracket Using the included **Self Drilling Tek Screws**

For Vehicles 2008 and up, the factory plug bracket can be attached to the tab welded to the **Super Hitch Cross Tube** by using the supplied **Self Drilling Tek Screws**. See **photo 10.1**



**Photo 14.1**

## Step 15

Tighten the Spare tire back into position.

# YOUR TOWING EQUIPMENT

## HITCH BALLS

Select by gross trailer weight rating, mounting platform thickness, hole size and coupler socket size. Platform must be at least 3/8 inch thick. Hole must not exceed threaded shank diameter by more than 1/16 inch. Use lock washer. Tighten per instructions. When tightened, shank must protrude beyond bottom of nut. Gross trailer weight rating and ball diameter are marked on Hitch balls.

## TRAILER COUPLERS

The coupler socket should be smooth, clean and lightly lubricated. Tighten or adjust per coupler manufacturer's instructions.

## SAFETY CHAINS

Connect safety chains properly EVERY TIME YOU TOW. Cross chains under coupler. Attach securely to the hitch or tow vehicle so they can't bounce loose. Leave only enough slack to permit full turning. Too much slack may prevent chains from maintaining control if other connections separate. Don't let chains drag on the road.

## TRAILER LIGHTS, TURN SIGNALS, ELECTRIC BRAKES AND BREAK AWAY SWITCH CONNECTIONS

Make these safety-critical connections EVERY TIME YOU TOW, no matter how short the trip. Check operation, including electric brake manual control, before getting on the road.

## SWAY CONTROLS

Sway controls can lessen the effects of sudden maneuvers, wind gusts and buffeting caused by other vehicles. We recommend them for trailers with large surface areas, such as travel trailers. Adjustable friction models can help control trailers with low tongue weight percentage.

## OTHER USEFUL EQUIPMENT

AIR SPRINGS, AIR SHOCKS or HELPER SPRINGS are useful for some hitch applications. A TRANSMISSION COOLER may be necessary for heavy towing. Many states require TOWING MIRRORS on both sides.

## TIRE INFLATION

Check often. Follow tow vehicle and trailer manufacturer's recommendations. Improper tire inflation can cause trailer sway.

**NO PASSENGERS IN TRAILERS:** NEVER allow people in trailers while towing, under any circumstances.

## RECOMMENDED TRUCK CAMPER INSTALLATION INSTRUCTIONS

When securing any heavy load (especially a camper) in your truck bed, your front tie down points should pull the load forward as much as possible. Some camper anchor points may differ with different manufacturers, as well as the camper jack mounting locations. Your Torklift tie down inserts have offset triangular brackets to increase the angle of pull. These are designed to be used in the front facing forward, and the rear facing rearward but can be used in either front or rear. These recommendations are to be considered and followed as a basic rule of thumb . Obviously there will be some applications where this may not be possible. At a minimum, if opposite pull of both front and rear Tiedowns cannot be achieved for whatever reason, you should have at least a forward pull at the front or rear location. If your camper does not come with Rubber Bumpers on the front lower portion of the camper, installing Rubber Bumpers (Torklift has Rubber Bumpers available Part A7001) or using a block of wood such as a 2 x 4 in the bed, will prevent the camper from damaging the front bulk head of the truck bed. Minor movement (or settling) can occur in some incidental harsh driving conditions (on or off road). A rubber bed mat is not a requirement to maintain the lifetime warranty on a Torklift system, but a strong recommendation simply as a safety precaution to protect the truck bed, the bottom of the camper and to give the camper additional support.

**TORKLIFT DOES NOT RECOMMEND:** Installing your truck camper in your truck on top of a drop in plastic bed liner!!! The drop in plastic bed liners can slide on top of the truck bed surface, and the camper can slide on top of the slick surface of the bed liner. The liner can also act as a spring causing a trampoline effect increasing vertical truck camper movement, independent of the vehicle, possibly resulting in truck bed, and camper damage!

### INSTRUCTIONS FOR FINISH MAINTENANCE OF TORKLIFT PRODUCTS

#### **POWDER COATED STEEL:**

To keep your Torklift products looking good follow these guidelines. All steel powder coated Torklift products are sandblasted for maximum adhesion and use a high quality industrial urethane based powder coat. Due to the extreme, harsh, undercar environment that your Torklift products live in, (consistently sprayed with corrosive road chemicals such as salt, and road debris), Torklift does not warranty the powder coated finish.

To minimize corrosion from these factors on powder coated steel products, Torklift recommends regularly cleaning and inspecting the powder coated surface and touching up any affected areas with an enamel or urethane based aerosol paint product. If there are any areas of surface rust, there are also aerosol spray rust converters available on the market that can be used as a preparation to touch-up paint application. These finish maintenance products are available at any automotive parts supplier.

#### **POLISHED STAINLESS STEEL :**

TorkLift utilizes quality grade 304 stainless steel in our stainless steel polished products. 304 stainless steel is well known for its anti-corrosive properties. However, in some environments such as coastal regions or when coming in contact with some road chemicals, corrosion may occur. For a quick clean simply use WD40 and a cloth rag. We also recommend occasional polishing of our polished stainless products to maintain their attractive finish. Use an approved stainless steel chrome or aluminum mag wheel polish cleaning product which can be purchased from any automotive parts supplier.



## **Frame Mounted Tie Downs**

Leading the camper tie down industry in strength, quality, advanced design and installation. TorkLift TRUE frame mounted tie downs are far superior to all tie down systems available.

The TorkLift system is unique in its design and is patented. Four independent tie down points (with no belly or crossbar) working much like your receiver type trailer hitch as the inserts are removable allowing the system to be virtually undetectable when not in use. They are designed for each make and model to fit tight to the frame so as not to compromise ground clearance. Torklift tie downs are not universal 'one size fits all' therefore all the problems with correct fit for each particular application have been eliminated.

**VISIT [WWW.TORKLIFT.COM](http://WWW.TORKLIFT.COM) FOR MORE INFORMATION**

## **Original SuperHitch & SuperHitch Magnum**

High strength extended hitch system engineered for safely towing all types of trailers behind your truck and camper. With a max towing capacity of 14,000 lbs(6350 Kg). with an extension\* , (17,000 lbs (7711Kg). to 20,000 lbs(9071 Kg). without\*) the Original SuperHitch and Superhitch Magnum are rated the strongest in the industry.



**CONTACT YOUR LOCAL DEALER FOR MORE DETAILS**

# **Torklift International Limited Lifetime Warranty Information**

**322 N. Railroad Ave. Kent, WA 98032**

Torklift will require proof of purchase to register, with pictures of any defective product before issuing a replacement. Torklift will not register any product without proof of purchase, which can be faxed, scanned, emailed, or mailed to the information provided below.

Torklift warrants it's hitches, custom hitch receivers, frame mounted tie downs, turnbuckles, and accessories (excluding wire harnesses which carry a 90 day warranty) from date of purchase against defects in material and workmanship under normal use and service for the ownership life of the original consumer purchaser. **ALL**

**COMMERCIAL APPLICATIONS ARE WARRANTED FOR A PERIOD OF 90 DAYS FROM THE DATE OF**

**INSTALLATION/SERVICE. Torklift will replace FREE OF CHARGE any part which proves defective in material or**

**workmanship when presented to Torklift, TRANSPORTATION CHARGES PREPAID by purchaser, at the address above. THIS**

**WARRANTY IS LIMITED TO DEFECTIVE PARTS**

**REPLACEMENT ONLY. LABOR CHARGES AND/OR DAMAGE INCURRED IN INSTALLATION OR REPLACEMENT, AS WELL**

**AS INCIDENTAL AND CONSEQUENTIAL DAMAGES**

**CONNECTED THEREWITH ARE EXCLUDED. This warranty**

**does not include the finish or paint on our products. Rusting, cracking or peeling of the finish is also excluded. Some states do not allow the**

**exclusion or limitation of incidental or consequential damages, so the above limitation or exclusion may not apply to you. Any damage to**

**Torklift products as a result of misuse, abuse, neglect, accident, improper installation or any use violative of**

**instructions furnished by Torklift or WHEN USED IN ANY COMMERCIAL APPLICATION WILL VOID THE WARRANTY.**

**This warranty gives you specific legal rights, and you may also have rights which vary from state to state. With warranty service, you may be able to go to a small claims court, a state court or a federal district court.**



# **TORKLIFT™**

## **INTERNATIONAL**

**322 N. Railroad Ave. Kent, WA 98032**

**Phone (800) 246-8132**

**Fax (253) 854-8003**

**Or visit our website: [www.TorkLift.com](http://www.TorkLift.com)**

Dear Valued Customer,

Thank you for making TorkLift your choice for truck, camper packages and accessories for your vehicle. By choosing TorkLift products, you have chosen a company that has been serving the RV industry for nearly 40 years and whose name has become synonymous with strength, quality and advanced design and installation.

Please take a few moments of your time to complete the Product Registration Warranty Card on the next page. When registering your newly purchased TorkLift products, you can be assured that your contact information is secure and that you and your product are getting the attention and respect that you deserve.

Thank you again for choosing TorkLift quality products.

**Register for your lifetime warranty and receive a free  
Torklift  
International gift.**

To Fax: Send copies of the questionnaire, warranty card and receipt to  
253-854-8003

To E-mail: Send copies of the questionnaire, warranty card and receipt to  
[warranty@torklift.com](mailto:warranty@torklift.com)

To Mail: Send to Torklift International 322 N Railroad Ave. Kent, WA 98032



## OFFICIAL WARRANTY REGISTRATION CARD

PLEASE FILL OUT THIS FORM COMPLETELY AND RETURN TO TORKLIFT WITHIN  
30 DAYS OF PURCHASE ACCOMPANIED BY A COPY OF YOUR ORIGINAL RECEIPT

### 1. PART(S) PURCHASED

TODAY'S DATE: \_\_\_\_\_

PART #: \_\_\_\_\_ PART #: \_\_\_\_\_  
 PART #: \_\_\_\_\_ PART #: \_\_\_\_\_  
 PART #: \_\_\_\_\_ PART #: \_\_\_\_\_

### 2. PURCHASER INFORMATION

NAME: \_\_\_\_\_  
 ADDRESS: \_\_\_\_\_

CITY: \_\_\_\_\_ STATE: \_\_\_\_\_ ZIP / POSTAL CODE: \_\_\_\_\_  
 PHONE: (\_\_\_\_) \_\_\_\_\_ - \_\_\_\_\_ EMAIL: \_\_\_\_\_

### 3. TRUCK INFORMATION

YEAR: \_\_\_\_\_ MAKE: \_\_\_\_\_  
 MODEL: \_\_\_\_\_ BED LENGTH: \_\_\_\_\_

### 4. CAMPER INFORMATION

YEAR: \_\_\_\_\_ MAKE: \_\_\_\_\_ MODEL: \_\_\_\_\_

### 5. DEALER INFORMATION

PURCHASED FROM: \_\_\_\_\_  
 ADDRESS: \_\_\_\_\_  
 CITY: \_\_\_\_\_ STATE: \_\_\_\_\_ ZIP / POSTAL: \_\_\_\_\_  
 INSTALLED BY: \_\_\_\_\_ OWNER ABOVE DEALER ANOTHER DEALER

IF ANOTHER DEALER, WHO: \_\_\_\_\_