

TORKLIFT **INTERNATIONAL**

**OVER 35 YEARS OF INNOVATION, QUALITY, SAFETY.
IMPORTANT OWNER-OPERATOR INSTALLATION INSTRUCTIONS**

Part F1006

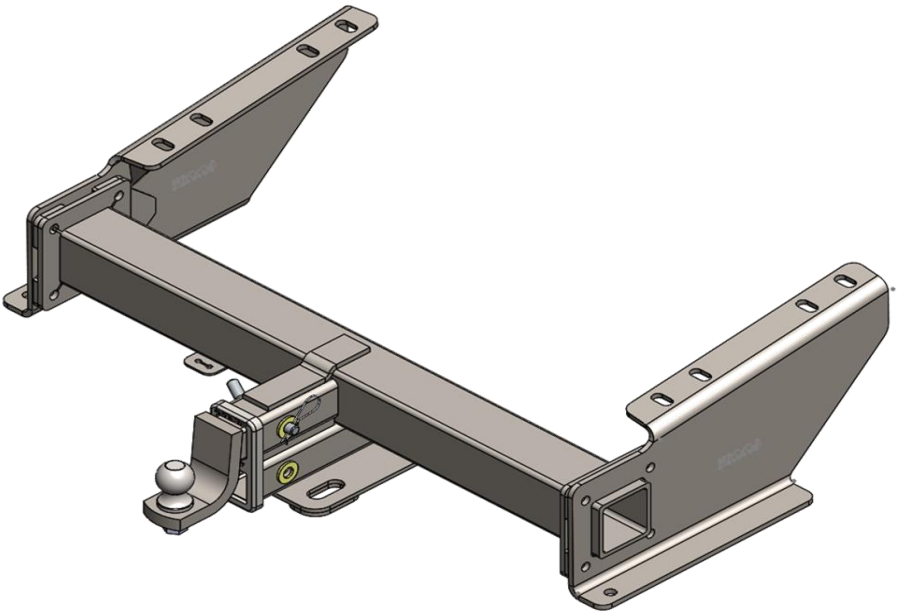









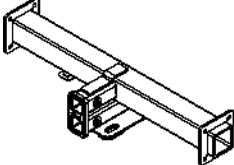
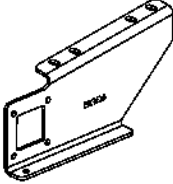











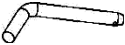

Version 2 BY: CW 8-14-17

TECH SUPPORT (800) 246-8132

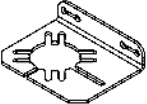
**AFTER INSTALL, PLEASE GIVE
THIS BOOKLET TO YOUR CUSTOMER**

Parts Inventory

Item Image	Item Description	Quantity
	<p style="text-align: center;">Double Receiver Cross Tube</p>	<p style="text-align: center;">1</p>
	<p style="text-align: center;">Side Plates (Passenger Side Shown)</p>	<p style="text-align: center;">2</p>
	<p style="text-align: center;">1"(2.54cm) x 2"(5cm) Plate Washer</p>	<p style="text-align: center;">6</p>
	<p style="text-align: center;">1/2" Star Washer</p>	<p style="text-align: center;">6</p>
	<p style="text-align: center;">1/2" Washer USS Grade 5</p>	<p style="text-align: center;">12</p>
	<p style="text-align: center;">1/2" Lock Washer High Alloy</p>	<p style="text-align: center;">14</p>
	<p style="text-align: center;">1/2" - 13 Hex Nut Grade 8</p>	<p style="text-align: center;">14</p>
	<p style="text-align: center;">1/2" Bolt Fisher</p>	<p style="text-align: center;">1</p>
	<p style="text-align: center;">1/2" - 13 x 1-1/2" Hex Bolt Grade 8</p>	<p style="text-align: center;">8</p>
	<p style="text-align: center;">1/2" - 13 x 2" Hex Bolt Grade 8</p>	<p style="text-align: center;">6</p>
	<p style="text-align: center;">5/8" - 11 x 2" Hex Bolt Grade 8</p>	<p style="text-align: center;">2</p>
	<p style="text-align: center;">5/8" SAE Flat Washer</p>	<p style="text-align: center;">4</p>
	<p style="text-align: center;">5/8" Lock Washer High Alloy</p>	<p style="text-align: center;">2</p>
	<p style="text-align: center;">5/8" Star Washer</p>	<p style="text-align: center;">2</p>
	<p style="text-align: center;">5/8" - 11 Hex Nut Grade 8</p>	<p style="text-align: center;">2</p>

Item Image	Item Description	Quantity
	5/8" Pin	2
	Pin Clip	2
	Universal Trailer Hitch Plug Bracket	1
	1/4" - 20 x 1" Hex Bolt	2
	1/4" Lock Washer	2
	1/4" Hex Nut	2
	#10 - 24 x 1" SS Phillips Truss Head Screw	4
	#10 SS Flanged Serrated Hex Nut	4

Step 1:

After ensuring that your vehicle is secure on flat level ground, begin by removing the rear bumper. Unplug the wiring harness attached to the bumper and loosen the two mounting bolts on each side. It is recommended to have an assistant hold the bumper while the mounting bolts are removed, as it is heavy and awkward. Also, disconnect the factory trailer hitch plug at this time.

(Photos 1.1, 1.2, 1.3)

Photo 1.1

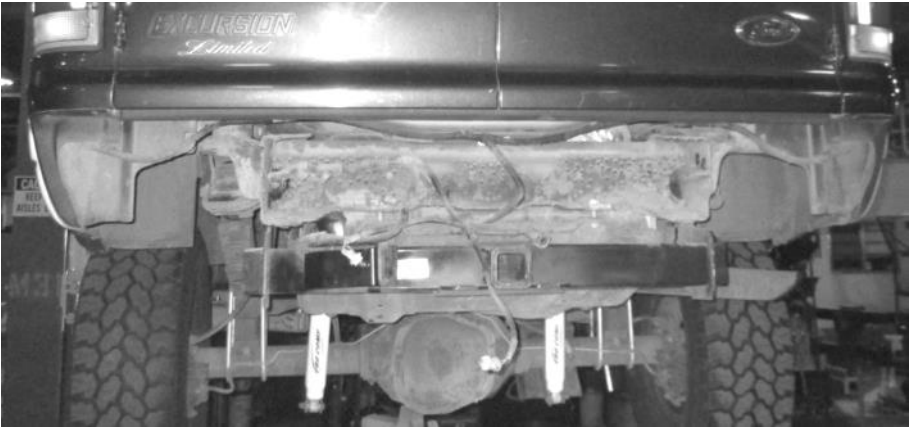

Photo 1.2



Note: If your vehicle is equipped with parking sensors, you will have two wiring harnesses to disconnect.

Photo 1.3



Step 2:

The fuel tank mounting straps must be loosened to allow the tank to drop around one inch, which will facilitate the installation of new mounting hardware into the frame. Follow this procedure exactly to prevent the fuel tank from falling.

- a) Using an 18mm socket, loosen the passenger rear fuel tank mounting bolt until it can be removed.
- b) Thread the same bolt back in three full turns, so that it can support the weight of the tank, but there is still approximately a 1" gap between the bolt head and tank strap.
- c) Repeat steps "a" and "b" for the remaining three bolts.
(Photos 2.1, 2.2)

Photo 2.1

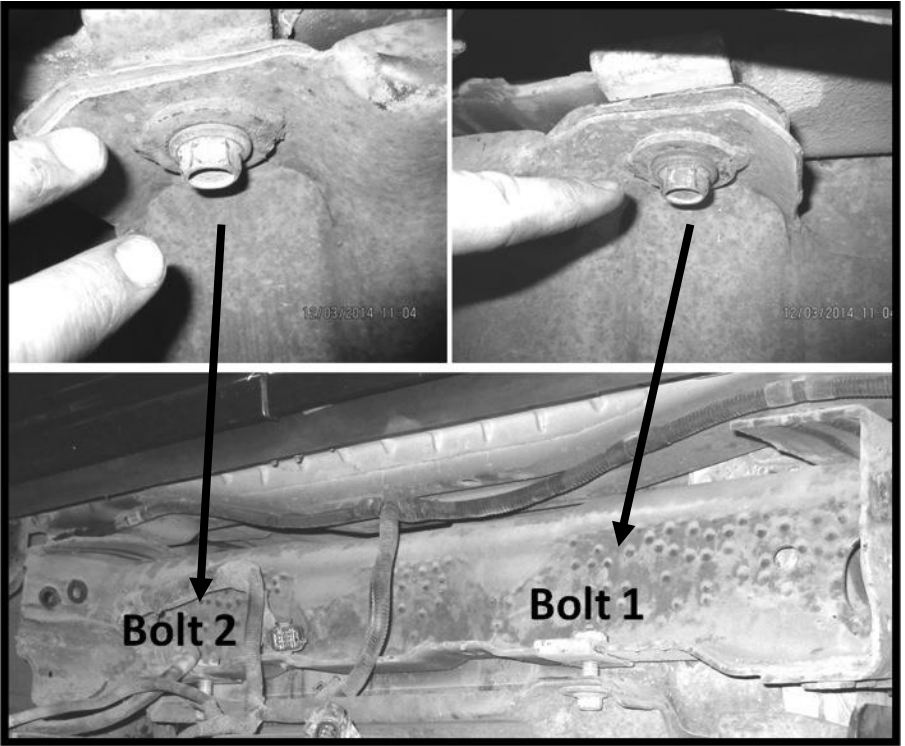
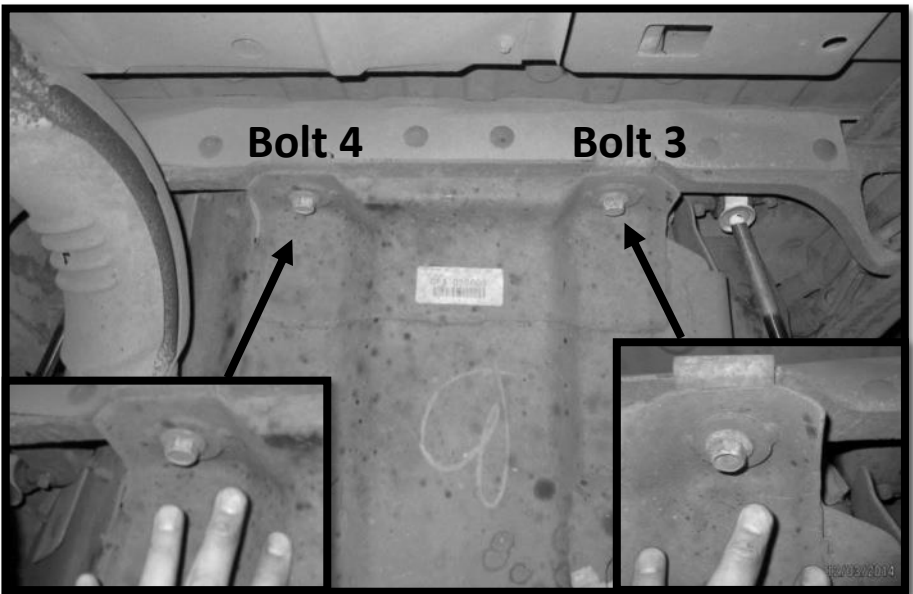

Photo 2.2



Step 3:

With the bumper removed and fuel tank lowered, the factory hitch can be removed. In order to protect the fuel tank, Ford installed one round head bolt per side to prevent removal of the hitch. The heads of these two bolts need to be drilled out to remove the hitch. To gain access to the bolts, the fuel tank can be shifted from side to side. Once the head has been sufficiently drilled, a pry bar or chisel can be used to remove the head completely. (Photos 3.1, 3.2, 3.3, 3.4)

Photo 3.1

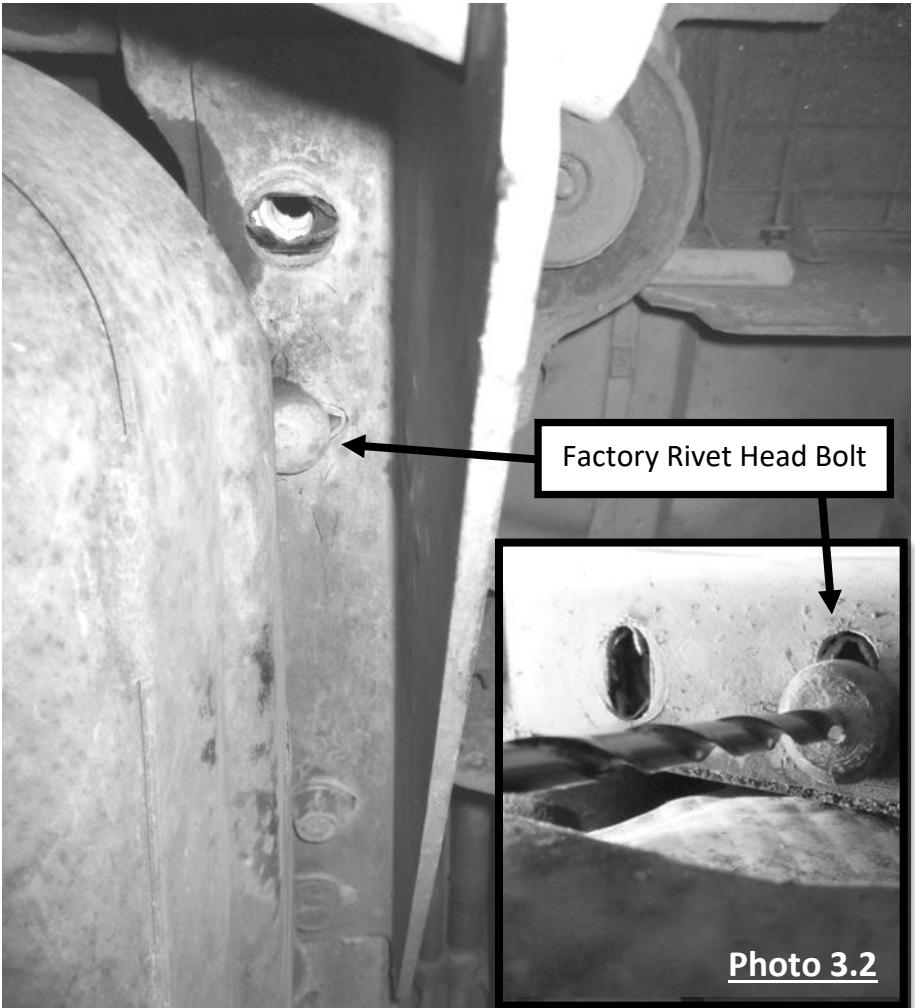

Photos 3.3 & 3.4

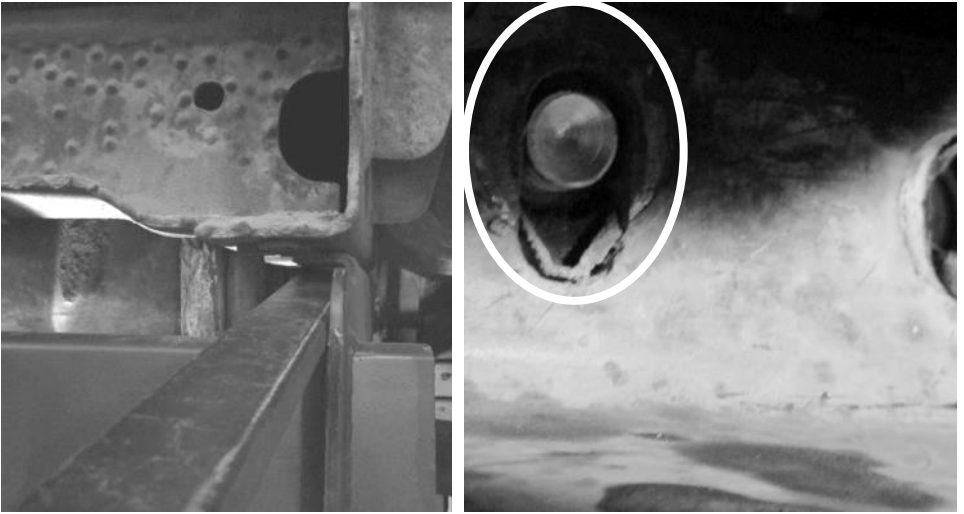

With the round heads removed, the remaining six bolts securing the factory hitch may be removed. The factory hitch and all fasteners may be discarded.

Step 4:

With the fuel tank loose, there is enough room to fish the new mounting hardware into place. Remove the factory nut plate pictured below from inside the frame if you have not already done so. Use the access hole cut into the frame cross member to install the pictured **5/8" bolt assembly** through the rear most hole in the frame with the threads facing down. (Figure 4.1 & Photo 4.2)

Figure 4.1 (5/8" Bolt Assembly)

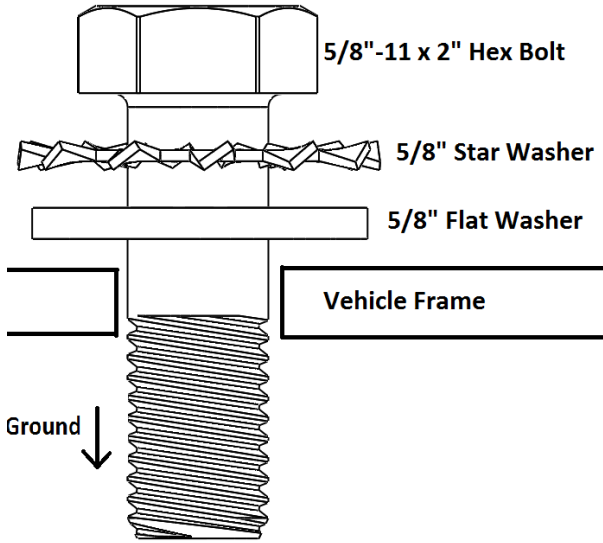
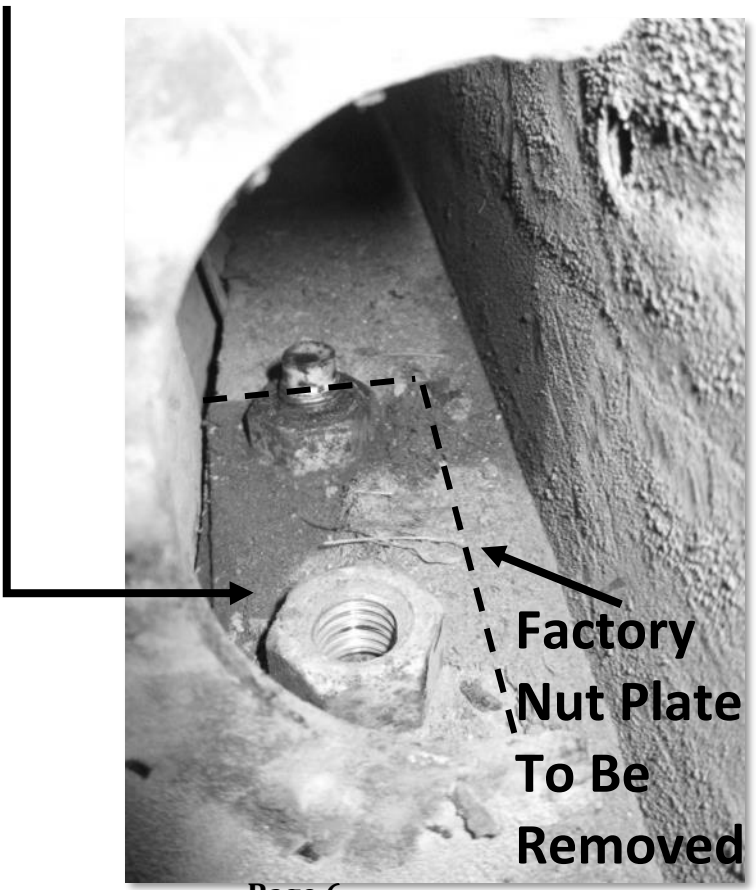

Photo 4.2



Step 5:

The remaining bolts will need to be fished into place using the supplied **1/2" bolt fisher**. The fuel tank has two indentations per side that will facilitate the installation of the following **1/2" bolt assembly** into the remaining three holes on each side of the frame. (Figure 5.1, Photos 5.2, 5.3, 5.4, 5.5)

Figure 5.1

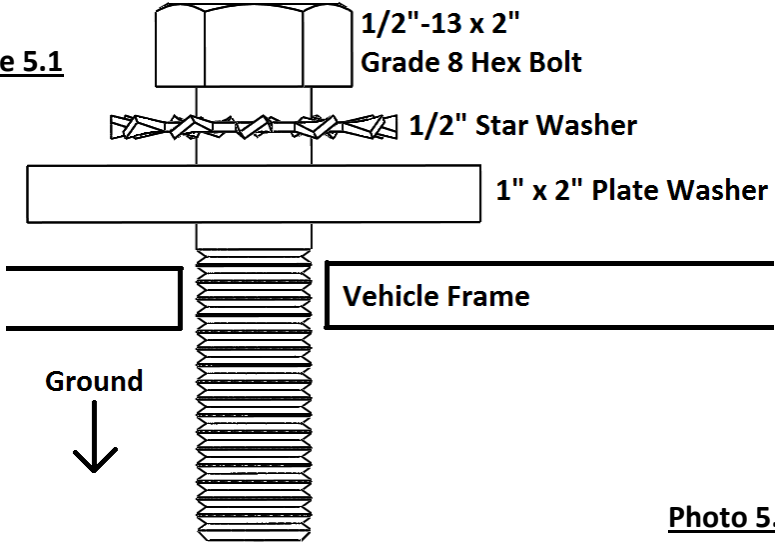

Photo 5.2



Photo 5.3



Photo 5.4



Photo 5.5



Step 6:

With all eight bolt assemblies fished into the vehicle frame, hold the driver side hitch plate up to the frame. The top of the hitch plate should bend in towards the fuel tank. Temporarily secure the hitch plate with a **1/2" hex nut**. Only spin this nut onto the threads enough to prevent the plate from falling.

With the side plate secure, install one **5/8" flat washer**, one **5/8" lock washer**, and one **5/8" hex nut** onto the protruding threads of the **5/8"-11 x 2" hex bolt**. Ensure that all remaining bolts protrude down through the holes in the hitch side plates and leave finger tight for now.

For the remaining three **1/2"-13 x 2" hex bolts**, install two **1/2" flat washers**, one **1/2" lock washer**, and one **1/2" hex nut** onto each. Leave all hardware loosely installed at this point. (Photo 6.1)

Photo 6.1

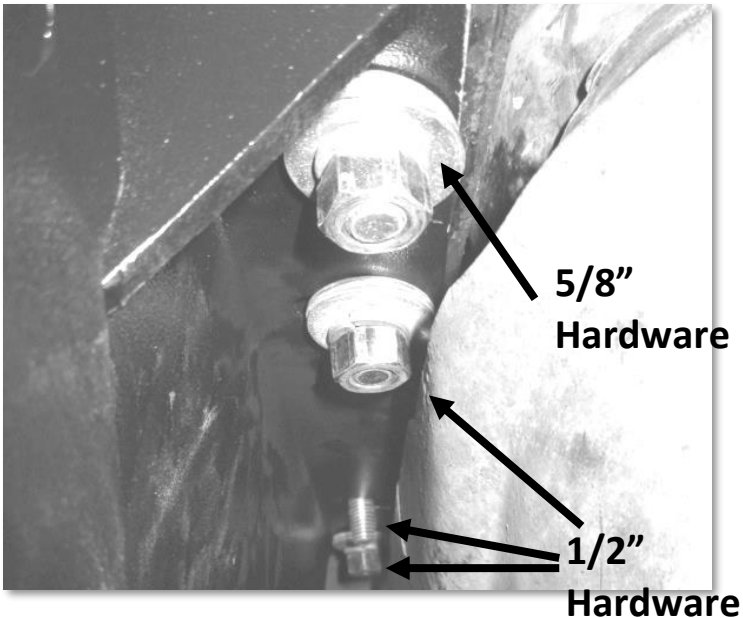

Step 7:

Repeat step six on the passenger side of the vehicle.

Next, install the cross tube between the two **SuperHitch Side Plates**. Secure the cross tube in place with four **1/2"-13 x 1-1/2" Hex Bolt Grade 8** per side, ensuring that the threads face outward. Secure each bolt with one **1/2" lock washer** and one **1/2" hex nut**. Torque the hex nuts on all eight bolts to 75 ft-lbs (101Nm). (Photo 7.1)

Photo 7.1

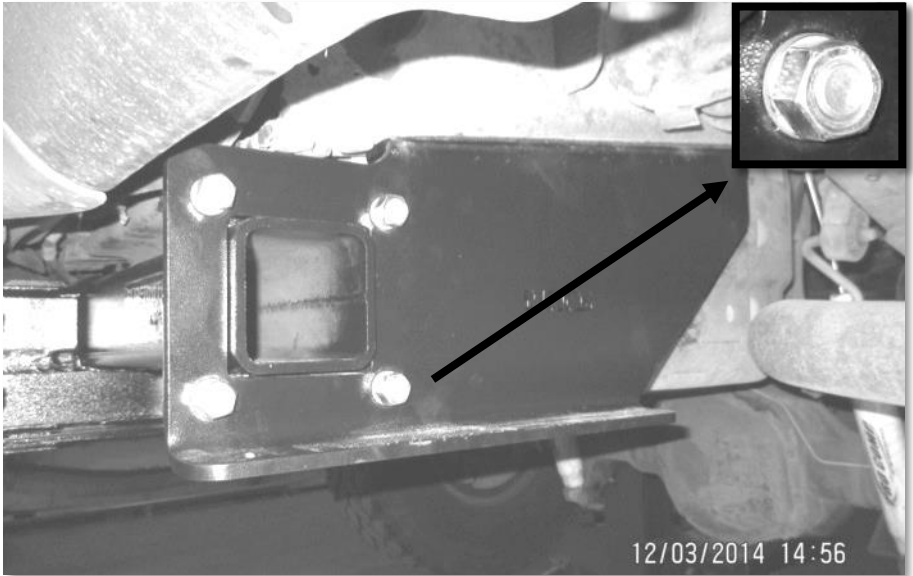

Step 8:

Gradually tighten the eight fasteners holding the side plates to the frame until the hitch is seated against the frame. Torque the two **5/8" hex nuts** to 100 ft-lbs (135Nm). Torque the six remaining **1/2" hex nuts** to 75 ft-lbs (101Nm).

Step 9:

Attach your factory trailer hitch plug to the supplied universal plug bracket using four **#10 SS Phillips truss head screws** and four **#10 SS serrated flange hex nuts**. Attach the universal plug bracket to the tab on the left side of the cross tube using two **1/4"-20 x 1" hex bolts**, two **1/4" lock washers**, and two **1/4" hex nuts**.

Step 10:

Reinstall your bumper using the factory mounting hardware and re-connect all wiring. Your F1006 Excursion Super Hitch installation is complete!

**SUPERTRUSS EXTENSION WEIGHT CAPACITIES
(SUPERTRUSS SOLD SEPARATELY)**

ASSEMBLE THE CHAIN, BOW SHACKLES, & TURNBUCKLES
AS SHOWN. TIGHTEN BOW SHACKLES AND
TURNBUCKLE JAM NUTS WITH HAND TOOLS
**(TIGHTEN TURNBUCKLES BY HAND
DO NOT USE TOOLS TO TENSION TURNBUCKLES)**



WARNING – READ CAREFULLY

**Dead weight (weight carrying) Weight Distributing (load equalizer)
Extension Length Tongue Weight Pull Weight Tongue Weight Pull Weight**

60" (152cm)	500lb (226kg)	5,000lb (2267kg)	1,000lb(453kg)	10,000lb (4535kg)
48" (122cm)	600lb (272kg)	6,000lb (2721kg)	1,200lb(544kg)	12,000lb (5443kg)
42" (107cm)	600lb (272kg)	6,000lb (2721kg)	1,200lb(544kg)	12,000lb (5443kg)
36" (91cm)	650lb (294kg)	6,500lb (2948kg)	1,200lb(544kg)	12,000lb (5443kg)
32" (81cm)	650lb (294kg)	6,500lb (2948kg)	1,200lb(544kg)	12,000lb (5443kg)
28"(71cm)	750lb (340kg)	7,500lb (3401kg)	1,200lb(544kg)	12,000lb (5443kg)
24" (61cm)	750lb (340kg)	7,500lb (3401kg)	1,400lb(635kg)	14,000lb (6350kg)
21 (53cm)	750lb (340kg)	7,500lb (3401kg)	1,400lb(635kg)	14,000lb (6350kg)

THE USE OF THIS PRODUCT WITHOUT A LOAD EQUALIZING SYSTEM LIMITS YOUR CAPACITY TO THE DEAD WEIGHT (WEIGHT CARRYING) CAPACITY. FAILURE TO STAY WITHIN THESE LIMITATIONS WILL RESULT IN DAMAGE AND VOID YOUR WARRANTY!!!! The Torklift SuperTruss Extension cannot be used with any other type of trailer hitch receiver. Any attempt to modify or recreate a SuperHitch receiver will result in a loss of warranty. The modification of another factory or aftermarket trailer hitch receiver in an attempt to use a Torklift SuperTruss extension can result in death or damage. The SuperHitch receiver made by Torklift is a special extra heavy-duty trailer hitch receiver, and the capacities stated for the SuperTruss extension are solely with the use of a Torklift SuperHitch. Please call if you have any questions on installs or otherwise at **1-800-246-8132**.

**THESE STEPS MAY VARY DEPENDING ON
WEIGHT DISTRIBUTION HITCH
MANUFACTURER**

**WEIGHT DISTRIBUTING
(LOAD EQUALIZING HITCH)**

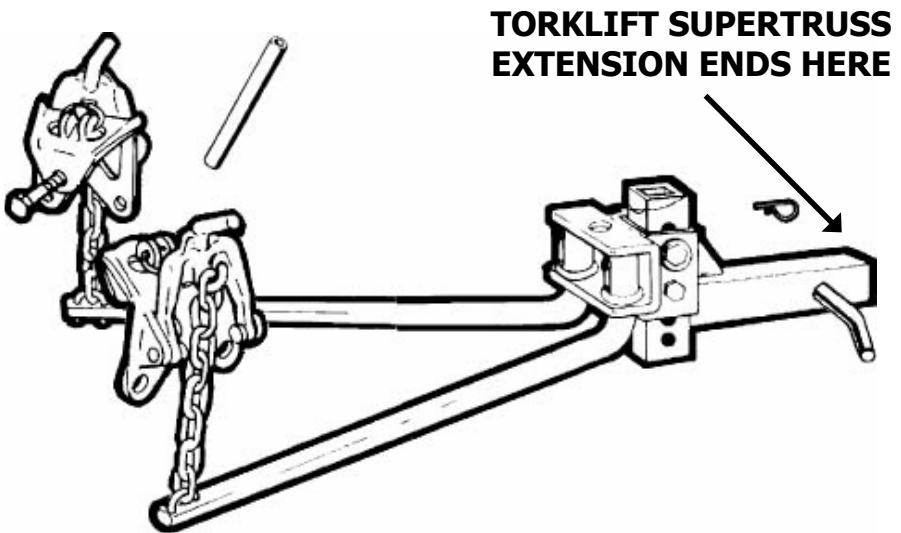

THIS TYPE OF HITCH IS REQUIRED IN
ADDITION TO YOUR SUPERHITCH TO
OBTAIN THE MAXIMUM RATED CAPACITY.
INCORRECT INSTALLATION OF THE WEIGHT
DISTRIBUTION SYSTEM MAY RESULT IN
DAMAGE TO YOUR VEHICLE.

WEIGHT DISTRIBUTION - CONTINUED

When towing trailers that exceed the dead weight rating on your extension it is mandatory to use a weight distributing type hitch/ball mount and related hardware (SPRING BARS, QUICK HOOKUP CLIPS ETC).

Not all weight distribution systems are rated at the same capacity. Your weight distributing ball mount and bars must be rated at least 100 lbs.(45kg) higher in regards to tongue weight, than your pre-existing tongue weight of your trailer **when fully loaded.**

It is of critical importance that your weight distribution system is not only rated high enough to match your existing tongue weight, but that you also have the system set up correctly.

We have supplied a formula to assist you in accurately determining the tongue weight load of your trailer when fully loaded. After accurately determining your tongue weight and making sure that your weight distribution system is rated high enough, your next step is to ensure the set up of the system is correct.

PLEASE READ CAREFULLY

1. The height of the ball must be determined before any assembly work can be started. To get ball height, measure trailer from ground level to top of ball coupler. Be sure trailer is parallel to ground. With your camper on your truck, fully loaded with gear and overloads adjusted, slide the weight distribution ball mount into the SuperHitch extension. Be sure the truck is on level ground. The measurement from ground to top of ball should be $1\frac{1}{2}$ "(4cm) higher than the level height of trailer top of ball measurement.

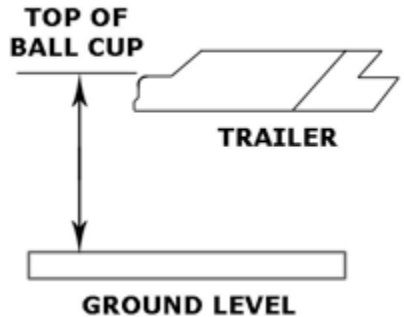

2. After ball height has been determined write down the ascertained height. EXAMPLE: Measured top of coupler height was 17"(43cm) from ground; ball height should be $18\frac{1}{2}$ "(47cm).

3. Slide the shank into the sleeve receiver, insert hitch pin and spring clip. With the ball attached to the ball mount, slide the ball mount up or down the shank until nearest dimension is obtained and the holes line up with shank. Insert the bolt in the bottom hole first (rest hitch head).

4. The rivet and 8 spacer washers are supplied in order to gain the correct downward angle of the spring bars. Insert rivet, and depending on the angle or the slope of bars that must be gained, use either 8 or the least amount of washers necessary in order to establish correct angle. The rivet and its accompanying washers are placed in the $\frac{1}{2}$ " hole between the "U" on the ball mount to acquire desired angle of spring bar. Once the spring bar angle has been determined, insert the top bolt with a flat washer, both sides, the lock washer, and nut to secure the unit in correct position, now insert the bottom bolt, use the lock washer and nut. Before tightening the bolts, lock the setscrew. (After the first day of towing, check set the screw for tightness).

See the following page for further illustrated diagrams

ILLUSTRATED DIAGRAMS

BEFORE HOOKING UP

Spring bar should hang down on a 10-13 degree angle when ball mount has been tilted back at 6-8 degree angle.

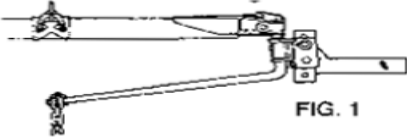

FIG. 1

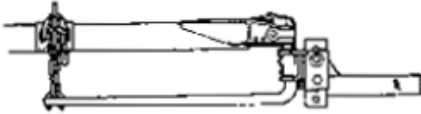

FIG. 2

AFTER HOOKING UP

Spring bar should be parallel with trailer frame, or a slight angle up or down. Slight bow or bend to bar is normal.

WRONG Readjust degree of tilt on ball mount, if you have more than 5 links of chain hanging free. The number of links should be the same on both bars.

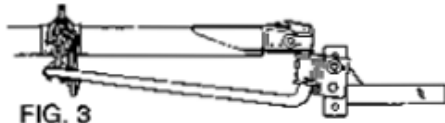
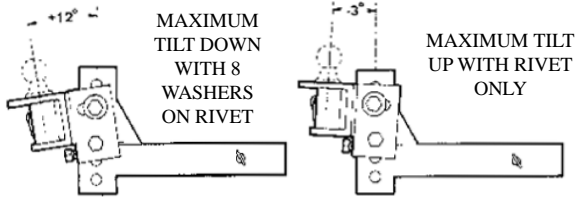

FIG. 3

EACH WASHER LOWERS CHAIN END OF SPRING BAR APPROX. 1-1/2"



MAXIMUM TILT DOWN WITH 8 WASHERS ON RIVET

MAXIMUM TILT UP WITH RIVET ONLY

BOLT-TOGETHER BALL MOUNT HAS 7-1/2" ADJUSTMENT, EACH ADJUSTMENT IS 1-1/4" EXTRA HY-LOW SHANKS AVAILABLE IF NEEDED

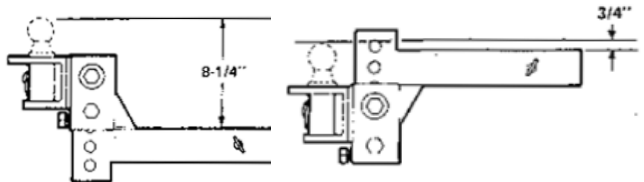

THESE STEPS MAY VARY DEPENDING ON WEIGHT

DISTRIBUTION HITCH MANUFACTURER

1. Put the ball mount into the sleeve and insert the 5/8" hitch pin using spring clip to lock the pin into place, hitch balls are not furnished with the hitch as there are several sizes. Normally they are supplied or may be purchased from the dealer to match the coupler of the trailer. Ball shank bushings are supplied to reduce the size of the ball hole in the hitch down to 1"(2cm) if needed.
2. Measure the towing vehicle ball height before adding load to towing vehicle. Hook the trailer to the truck. Lock on the ball. To make hooking up easier and safer - raise front of the trailer and back of the towing vehicle above level with the trailer tongue jack. This removes some of the tension by reducing the distance between the spring bar and hook-up arm.

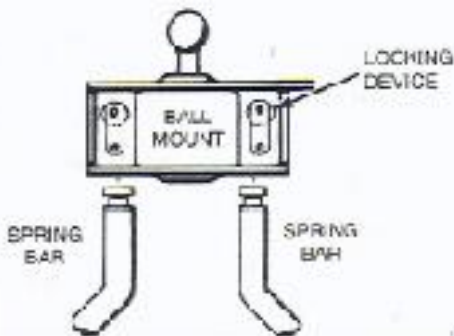

3. This step may vary depending on the manufacturer. The spring bars can be inserted into either side of the ball mount. (There is no 'right' or 'left' bar). To insert and lock spring bar in socket, hold the bar under socket and push up. The spring bar will automatically be locked into position by the

spring bar-locking device. (Check to make sure the bar is locked in by moving it up and down at the chain end.) To remove the spring bars, just pull out the locking device or swing the bar around under the bumper and it will drop free.

4. To find correct location on trailer frame for quick hook-up bracket, hold the chain straight up and down and free of twist center hook-up bracket on frame and tighten. Set the screw 1/4 turn only. **DO NOT OVERTIGHTEN.** On straight tongue trailers a poli-tongue adapter is necessary

5. You are now ready to put tension on the spring bars. When using the quick hook-up, lower the arm and slip link of chain over hook. Insert hook-up handle over the end of the quick hook-up arm. Lift and flip over center. (See fig A).

Continue onto next page for further directions

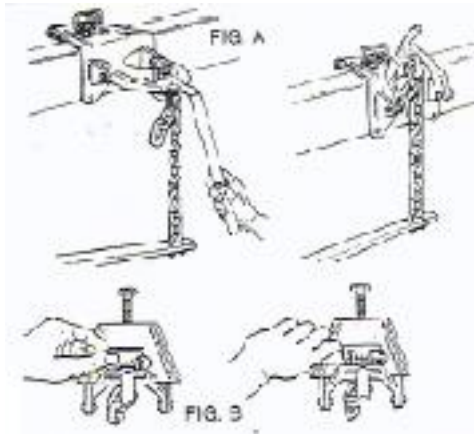

CAUTION: MAKE SURE THAT THE HOOK-UP ARM IS COMPLETELY SEATED AND THAT THE SPRING BAR IS PUSHED DIRECTLY UNDER THE HOOK-UP CHAIN HOOK.

Now install the hook-up locking clip through locking ears and over hook on hook-up arm. (See fig B)

6. Release the trailer tongue jack by adjusting the chain links up or

down; the desired load on the bars will be gained. Now lock the coupler on to the ball and raise the front of the trailer approximately 3"(8cm) above level. Now attach the chain link to the hook-up clip. It should require 50-100 lbs.(22-45kg) of force to properly tension the spring bars. Bow or bend to the spring bar is normal.

7. To release tension on the spring bars, raise the front of the trailer and the back of the towing vehicle above level (approx. 3"(8cm)) with the trailer tongue jack. Remove the locking clip from the bracket. Insert the handle over arm. Carefully lower the arm with the handle. It will require effort to bring the arm over the center and then to resist the chain tension as the arm rotates downward.

MAINTENANCE:

Use heavy lubrication such as fibre type wheel bearing grease on the hitch ball and on spring bars inside the ball mount. This is recommended every day. Also keep the hitch painted to prevent rust and check the tightness of bolts regularly. Clean out old grease and do not let it harden inside of the ball mount

**IMPORTANT CONSUMER
INFORMATION ON TOWING**

TOWING EQUIPMENT OWNERS: Make sure all of the operators of your equipment read and understand this information before towing. Save for reference. This will help you properly select, use, and maintain your towing equipment. Refer to your owner's manuals for your tow vehicle, trailer, and other parts of your towing system. Learn the capabilities and limitations of each part. The **GROSS TRAILER WEIGHT** and **TONGUE WEIGHT** are two of the most important items to consider. **THESE WEIGHTS MUST NEVER EXCEED THE LOWEST RATING OF ANY PART OF YOUR TOWING SYSTEM.** **GROSS TRAILER WEIGHT** is the weight of the trailer plus all cargo. Measure the **GROSS TRAILER WEIGHT** with the fully loaded trailer on a level surface. The weight is the downward force exerted on the ball by the trailer coupler. Measure the **TONGUE WEIGHT** with the fully loaded trailer on a level surface. The coupler must be at its normal towing height. Use a commercial scale or a bathroom scale. Set up the bathroom scale as shown for heavy tongue weights.

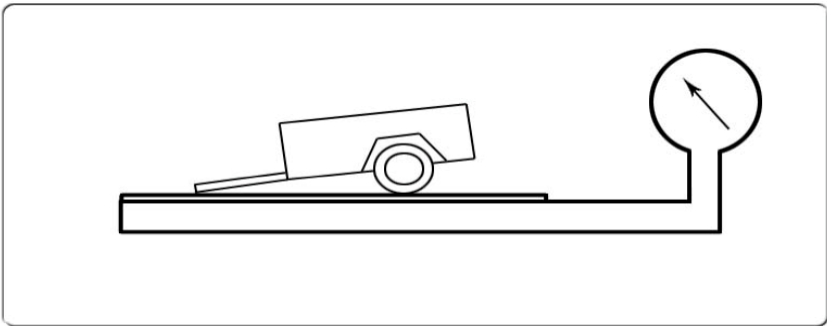

**Method for Measuring
Gross Trailer Weight**

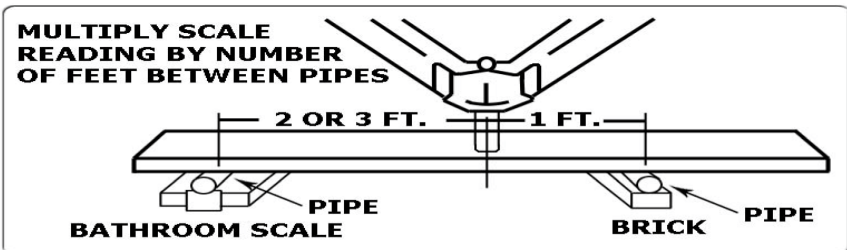

**Method for Measuring
Trailer Tongue Weight**

YOUR TOWING EQUIPMENT

HITCH BALLS

Select by gross trailer weight rating, mounting platform thickness, hole size and coupler socket size. Platform must be at least 3/8 inch thick. Hole must not exceed threaded shank diameter by more than 1/16 inch. Use lock washer. Tighten per instructions. When tightened, shank must protrude beyond bottom of nut. Gross trailer weight rating and ball diameter are marked on Hitch balls.

TRAILER COUPLERS

The coupler socket should be smooth, clean and lightly lubricated. Tighten or adjust per coupler manufacturer's instructions.

SAFETY CHAINS

Connect safety chains properly EVERY TIME YOU TOW. Cross chains under coupler. Attach securely to the hitch or tow vehicle so they can't bounce loose. Leave only enough slack to permit full turning. Too much slack may prevent chains from maintaining control if other connections separate. Don't let chains drag on the road.

TRAILER LIGHTS, TURN SIGNALS, ELECTRIC BRAKES AND BREAK AWAY SWITCH CONNECTIONS

Make these safety-critical connections EVERY TIME YOU TOW, no matter how short the trip. Check operation, including electric brake manual control, before getting on the road.

SWAY CONTROLS

Sway controls can lessen the effects of sudden maneuvers, wind gusts and buffeting caused by other vehicles. We recommend them for trailers with large surface areas, such as travel trailers. Adjustable friction models can help control trailers with low tongue weight percentage.

OTHER USEFUL EQUIPMENT

AIR SPRINGS, AIR SHOCKS or HELPER SPRINGS are useful for some hitch applications. A TRANSMISSION COOLER may be necessary for heavy towing. Many states require TOWING MIRRORS on both sides.

TIRE INFLATION

Check often. Follow tow vehicle and trailer manufacturer's recommendations. Improper tire inflation can cause trailer sway.

NO PASSENGERS IN TRAILERS: NEVER allow people in trailers while towing, under any circumstances.

HELPFUL TOWING TIPS

TRAILER LOADING

Proper loading helps prevent sway. Place heavy object on the floor ahead of the axle. Balance the load side-to-side. Secure it to prevent shifting. Tongue weight should be 10-15 percent of gross weight for most trailers. Too low a percentage of tongue weight can cause sway. NEVER load the trailer rear heavy. LOAD THE TRAILER HEAVIER IN FRONT

DRIVING

The additional weight of a trailer affects acceleration, braking, and handling. Allow extra time for passing, stopping, and changing lanes. Severe bumps can damage your towing vehicle, hitch, and trailer. Drive slowly on rough roads. STOP AND MAKE A THOROUGH INSPECTION IF ANY PART OF YOUR TOWING SYSTEM STRIKES THE ROAD. CORRECT ANY PROBLEMS BEFORE RESUMING TRAVEL.

CHECK FOR EXCESSIVE SWAY AND ELIMINATE IT

Excessive sway can lead to loss of control. Sway motion should settle out quickly. Sway tends to increase on a downgrade. Starting slowly, increase speed in gradual steps. If sway occurs, adjust your trailer load and equipment. Repeat until the trailer is stable at highway speed. Do this whenever your trailer loading changes.

IF TRAILER SUDDENLY STARTS TO SWAY

Turbulence from another vehicle, a wind gust, or a downgrade can cause sudden sway. So can a shift of the trailer's load or a trailer tire blowout. IF THE TRAILER SWAYS, IT IS THE DRIVER'S RESPONSIBILITY TO ASSESS THE SITUATION AND TAKE APPROPRIATE ACTION. Below are suggestions that may apply, depending on conditions:

DO

- Reduce your speed gradually
- Hold the steering wheel as steady as possible
- If your trailer has electric brakes, apply the brakes alone, without using the tow vehicle's brakes.

DON'T

- Don't hit your brake pedal hard unless absolutely necessary. A "jack-knife" can result.
- Don't try to steer out of the sway condition. Sudden or violent steering can make it worse.
- Don't speed up. Sway increases as you go faster.
- Don't continue towing a trailer that tends to sway. You may lose control during an emergency maneuver or if the conditions listed above occur.

Torklift International Limited Lifetime Warranty Information

322 N. Railroad Ave. Kent, WA 98032

Torklift will require proof of purchase to register, with pictures of any defective product before issuing a replacement. Torklift will not register any product without proof of purchase, which can be faxed, scanned, emailed, or mailed to the information provided below. Torklift warrants its hitches, custom hitch receivers, frame mounted tie downs, turnbuckles, and accessories (excluding wire harnesses which carry a 90 day warranty) from date of purchase against defects in material and workmanship under normal use and service for the ownership life of the original consumer purchaser. All plastic, rubber, and/ or electrical components maintain a warranty of up to one year from the date of the purchase. **ALL COMMERCIAL APPLICATIONS ARE WARRANTED FOR A PERIOD OF 90 DAYS FROM THE DATE OF INSTALLATION/SERVICE.** Torklift will replace **FREE OF CHARGE** any part which proves defective in material or workmanship when presented to Torklift, **TRANSPORTATION CHARGES PREPAID** by purchaser, at the address above. **THIS WARRANTY IS LIMITED TO DEFECTIVE PARTS REPLACEMENT ONLY. LABOR CHARGES AND/OR DAMAGE INCURRED IN INSTALLATION OR REPLACEMENT, AS WELL AS INCIDENTAL AND CONSEQUENTIAL DAMAGES CONNECTED THEREWITH ARE EXCLUDED.** This warranty does not include the finish or paint on our products. Rusting, cracking or peeling of the finish is also excluded. Some states do not allow the exclusion or limitation of incidental or consequential damages, so the above limitation or exclusion may not apply to you. Any damage to Torklift products as a result of misuse, abuse, neglect, accident, improper installation or any use violative of instructions furnished by Torklift or **WHEN USED IN ANY COMMERCIAL APPLICATION WILL VOID THE WARRANTY.** This warranty gives you specific legal rights, and you may also have rights which vary from state to state. With warranty service, you may be able to go to a small claims court, a state court or a federal district court.



INTERNATIONAL

322 N. Railroad Ave. Kent, WA 98032

Phone (800) 246-8132

Fax (253) 854-8003

Or visit our website: www.TorkLift.com

Dear Valued Customer,

Thank you for making TorkLift your choice for truck, camper packages and accessories for your vehicle. By choosing TorkLift products, you have chosen a company that has been serving the RV industry for nearly 40 years and whose name has become synonymous with strength, quality and advanced design and installation.

Please take a few moments of your time to complete the Product Registration Warranty Card on the next page. When registering your newly purchased TorkLift products, you can be assured that your contact information is secure and that you and your product are getting the attention and respect that you deserve.

Thank you again for choosing TorkLift quality products.

**Register for your lifetime warranty and receive a free
Torklift
International gift.**

To Fax: Send copies of the questionnaire, warranty card and receipt to
253-854-8003

To E-mail: Send copies of the questionnaire, warranty card and receipt to
warranty@torklift.com

To Mail: Send to Torklift International 322 N Railroad Ave. Kent, WA 98032



OFFICIAL WARRANTY REGISTRATION CARD

PLEASE FILL OUT THIS FORM COMPLETELY AND RETURN TO TORKLIFT WITHIN
30 DAYS OF PURCHASE ACCOMPANIED BY A COPY OF YOUR ORIGINAL RECEIPT

1. PART(S) PURCHASED

TODAY'S DATE: _____

PART#: _____ PART#: _____

PART#: _____ PART#: _____

PART#: _____ PART#: _____

2. PURCHASER INFORMATION

NAME: _____

ADDRESS: _____

CITY: _____ STATE: _____ ZIP / POSTAL CODE: _____

PHONE: (____) _____ - _____ EMAIL: _____

3. TRUCK INFORMATION

YEAR: _____ MAKE: _____

MODEL: _____ BED LENGTH: _____

4. CAMPER INFORMATION

YEAR: _____ MAKE: _____ MODEL: _____

5. DEALER INFORMATION

PURCHASED FROM: _____

ADDRESS: _____

CITY: _____ STATE: _____ ZIP / POSTAL: _____

INSTALLED BY: _____ OWNER _____ ABOVE DEALER _____ ANOTHER DEALER _____

IF ANOTHER DEALER, WHO: _____