

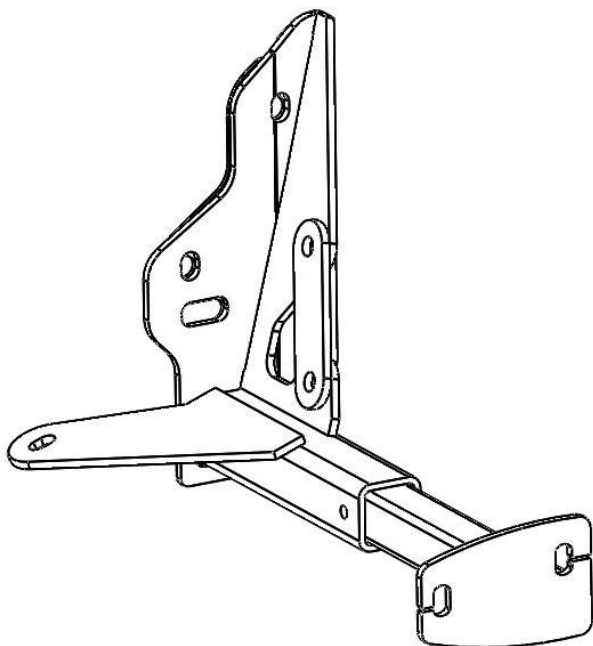

**OVER 35 YEARS OF INNOVATION, QUALITY, SAFETY.
IMPORTANT OWNER-OPERATOR INSTALLATION INSTRUCTIONS**

Part F2018



Version 3 BY: CW (3/3/15)

TECH SUPPORT (800) 246-8132

**AFTER INSTALL, PLEASE GIVE
THIS BOOKLET TO YOUR CUSTOMER**

Warnings

Truck Bed and Camper Protection

Torklift **does not** recommend installing your camper on top of a plastic bed liner (or other compressible material such as foam). These materials can act as a spring, causing increased vertical truck camper movement independent of the vehicle. Plastic bed liners can slide on the truck bed surface, and the truck camper can slide on top of the bed liner. Using a plastic bed liner or similar compressible material will void your warranty and may additionally cause truck bed and/or camper damage.











Minor movement or settling can occur in some incidental harsh driving conditions (on or off-road). A rubber bed mat is recommended to protect the truck bed and camper, but is not a requirement to maintain the Torklift legendary lifetime warranty.





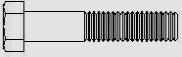

Suspension

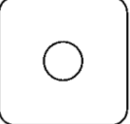
To significantly reduce body roll, sag and sway Torklift strongly recommends the StableLoad. Torklift International StableLoads improve safety, handling, and to help level your truck. More information can be found at (www.Torklift.com/stableload).

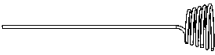
If your truck is additionally equipped with suspension air bags Torklift cautions against over pressurization as this may lead to unsafe vehicle handling characteristics. We have found that airbags used in conjunction with StableLoads have allowed operators to lower air bag pressure by 50% or more. Only pressurize suspension air bags enough to level the truck.

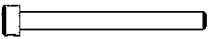
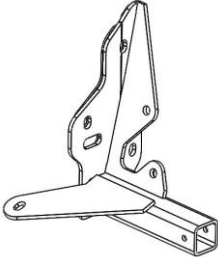
Parts Inventory

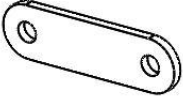
Item Image	Item Description	Quantity
	1/2"-13 x 2" Grade 5 Hex Bolt	6
	1/2"-13 x 1.5" Grade 5 Hex Bolt	2
	1" x 2" Plate Washer	8
	1/2" SAE Flat Washer	10
	1/2" Star Washer	6
	1/2" Lock Washer	8
	1/2"-13 Grade 5 Nut	8
	3/8"-16 x 2" Grade 8 Hex Bolt	2
	3/8" USS Flat Washer	4
	3/8" Star Washer	4
	3/8"-16 Lock Washer	2
	3/8"-16 Grade 8 Hex Nut	2
	2"x2" Plate Washer	2

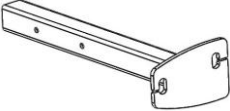
Item Image	Item Description	Quantity
	1/2" Bolt Fisher	2
	3/8" Bolt Fisher	1
	1/4" x 2-1/4" Snapper Pin	2
	Driver Side Tie Down Receiver	1
	Passenger Side Tie Down Receiver	1
	Gusset Connector	1
	Tie Down Spacer Plate	2
	Straight Tie Down Insert	2

Step 1:

Begin by attaching the coiled end of one of the **1/2" bolt fishers** to a **1/2"-13 x 2" Grade 5 Hex Bolt**. Slide one **1/2" star washer** followed by one **1" x 2" Plate Washer** onto the non coiled end of the bolt fisher. See Figure 1.1 for hardware order.

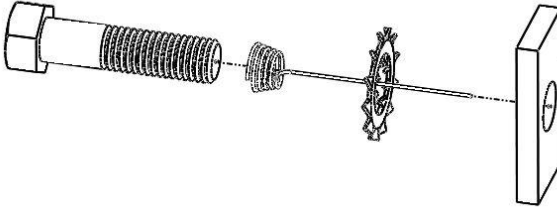

Figure 1.1

Beginning on the driver side of the frame, insert the non-coiled end of the bolt fisher into hole E. Guide the bolt fisher back out through hole F. (See figure 1.2). Pull the bolt through the frame and out of hole F. Leave the bolt fisher attached.

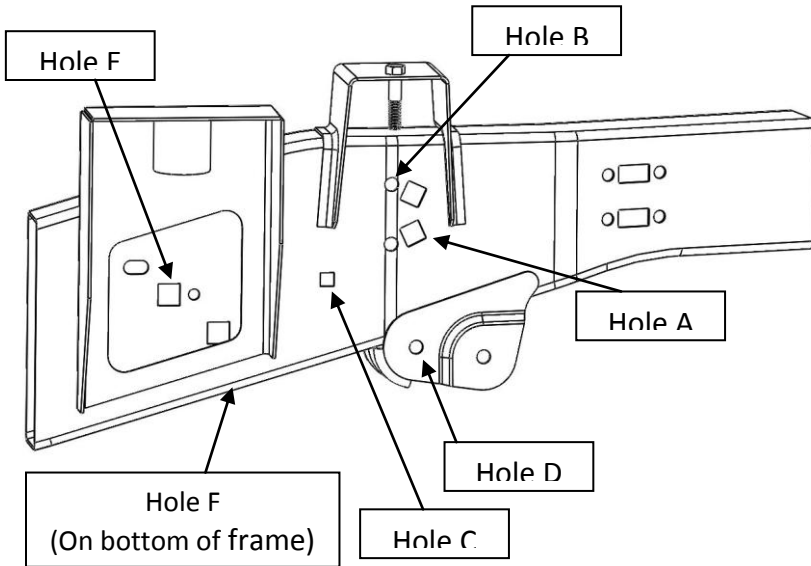

Figure 1.2 - Driver side shown

Step 2:

Repeat the bolt fishing process to fish one **1/2"-13 x 2" Grade 5 Hex Bolt**, one **1/2" Star Washer**, and one **1" x 2" Plate Washer** into hole A (refer back to figure 1.1 for hardware order). Guide the bolt fisher out through hole B in the frame. Pull the hardware into the frame, but do not pull the bolt out through the hole at this time. Leave the bolt fisher attached.

Step 3:

Attach the coiled end of the **3/8" Bolt Fisher** to the **3/8"-16 x 2" Grade 8 Hex Bolt**. Slide one **3/8" Star Washer**, one **3/8" USS Flat Washer**, another **3/8" Star Washer**, and one **1"x2" Plate Washer** onto the non-coiled end of the bolt fisher. Refer to figure 3.1 for hardware order.

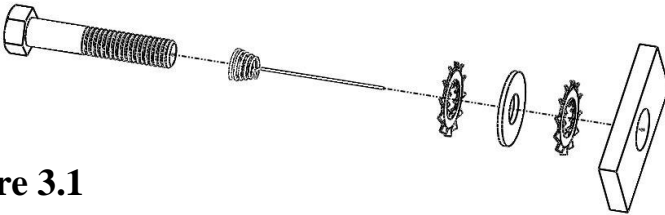

Figure 3.1

Insert the non-coiled end of the bolt fisher into hole A and guide it out through hole C. Note: On trucks equipped with cable actuated parking brakes, hole C may be triangular in shape.

Pull the hardware into the frame, but do not pull the bolt through hole C at this time. Leave the bolt fisher attached.

Step 4:

If your truck is equipped with cable actuated parking brakes, you will need to remove the bolt holding the cable bracket from the bottom side of the leaf spring bracket.

Once the bracket has been removed, slide the tie down receiver tube in between the two parking brake cables. The upper cable will fit into the cutout in the upper gusset of the **Driver Side Tie Down Receiver**.

Step 5

Place the non-coiled ends of the bolt fishers through the **Tie Down Spacer Plate** and the **Driver Side Tie Down Receiver** as shown in figure 5.1.

If your truck is equipped with an electric parking brake, the bolt protruding from hole C will go through the middle hole of the **Tie Down Spacer Plate** and **Tie Down Receiver** (driver side only).

Trucks with electric parking brakes use this hole for driver side only.

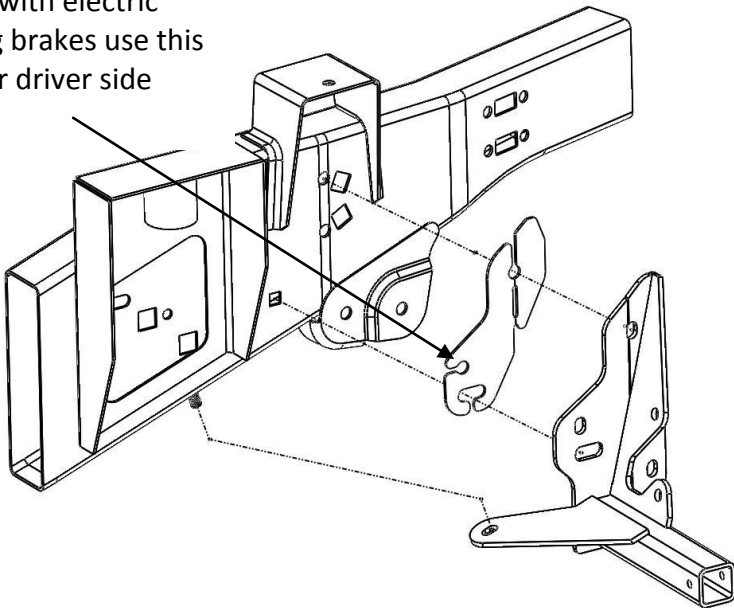

Figure 5.1 - Driver side shown

Step 6:

Place the **Spacer Plate** and **Tie Down Receiver** up against the frame and slide it up. Guide the receiver plate so that the bolt protruding from hole F In the bottom of the frame goes through the hole in the lower **Tie Down Receiver Plate**.

Carefully remove the bolt fisher from the bolt in hole F and loosely secure it with one **1/2" USS Flat Washer**, one **1/2" Star Washer** and one **1/2"-13 Grade 5 Hex Nut**.

Step 7:

Gently pull on the non-coiled end of each remaining bolt fisher until the bolts protrude from the frame and out through the **Spacer Plate** and **Tie Down Receiver Plate**.

Carefully remove the bolt fisher from the 1/2" bolt. While holding the bolt with one hand, place one **1/2" USS Flat Washer** and one **1/2" Lock Washer** over the end of the bolt. Secure the bolt with one **1/2"-13 Grade 5 Hex Nut**.

Carefully remove the bolt fisher from the **3/8" Hex Bolt**. While holding the bolt with one hand, place one **2"x2" Plate Washer**, one **3/8" Flat Washer** and one **3/8" Lock Washer** over the end of the bolt. Secure the bolt with one **3/8"-16 Grade 8 Hex Nut**.

Step 8:

Place one **1/2"-13 x 2" Grade 5 Hex Bolt** with one **1/2" Star Washer** and one **1" x 2" Plate Washer** into the bottom of the leaf spring hanger. Guide the bolt out through hole D and the **Tie Down Receiver** plate. Secure the bolt with one **1/2" USS Flat Washer**, one **1/2" Lock Washer** and one **1/2"-13 Grade 5 Hex Nut**.

Step 9:

Snug the bolts in the following order:

1. Bolt in hole **F**
2. Bolt in hole **D**
3. Bolt in hole **C**
4. Bolt in hole **B**

Step 10:

For trucks with cable actuated parking brakes, reattach the parking brake cable bracket to the underside of the leaf spring hanger. You will need to bend the bracket down to allow the lower parking brake cable to sit under the tie down receiver tube.

Step 11:

With the upper parking brake cable sitting in the cutout of the driver side tie down receiver gusset, install one **1/2"-13 x 1.5" grade 5 hex bolt** with one **1/2" SAE Flat Washer** into each hole in the **Gusset Connector** and through the tie down receiver gusset as shown in step 10. Secure each bolt with one **1/2" SAE Flat Washer**, one **1/2" Lock Washer**, and one **1/2"-13 Grade 5 Hex Nut**.

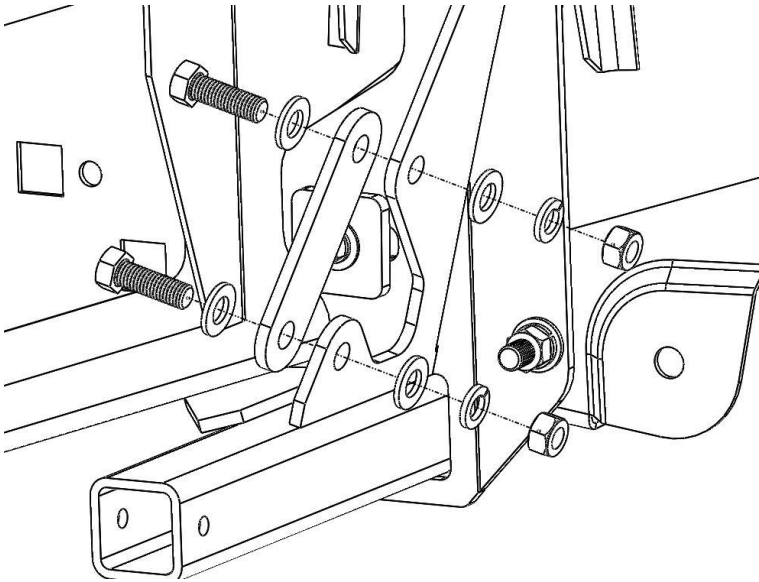

Figure 11.1

Torque all 1/2" hardware to 65 ft-lbs.

Torque all 3/8" hardware to 38 ft-lbs.

The driver side Installation is complete.

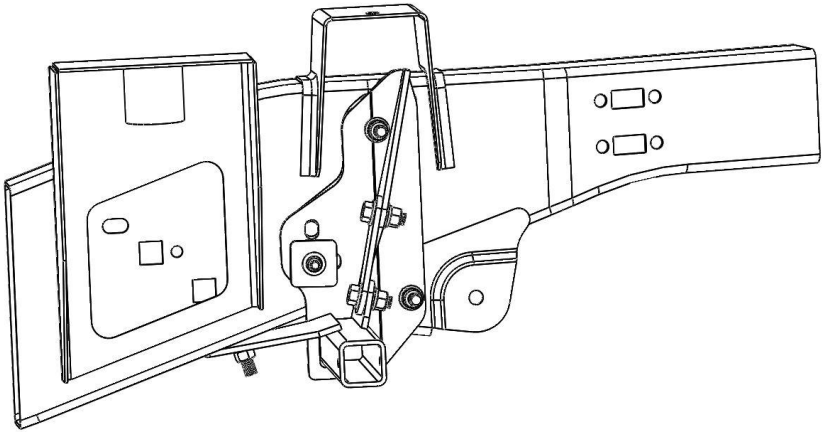

Figure 11.2 - Driver Side (Parking cables not shown)

Step 12:

Repeat the installation process on the passenger side of the vehicle. Installations on this side of the vehicle will not use the middle hole in the Spacer Plate.

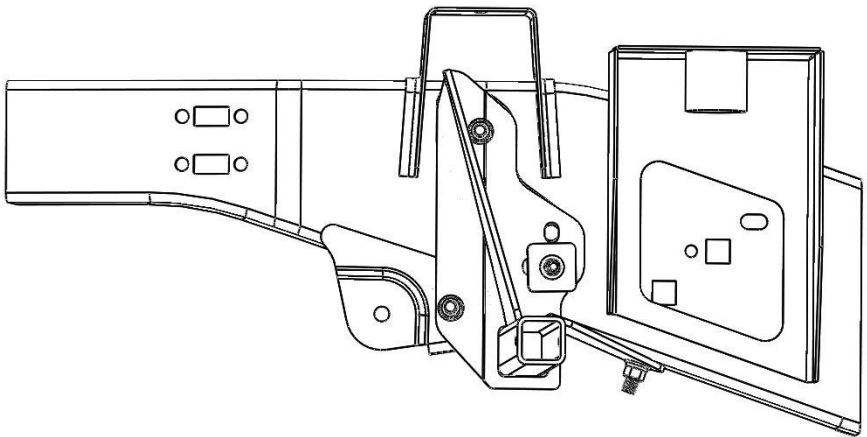

Figure 12.1 - Passenger Side Shown

Step 13:

Install the **Straight Tie Down Inserts** into each receiver, with the offset end facing toward the front of the truck. Use the **1/4" x 2-1/4" Snapper Pins** to pin the **Tie Down Inserts** into place. Either hole in the insert can be used as long as it provides sufficient clearance between the turn buckle and vehicle body.

Installation is complete.

TIEDOWN INSERT INSTALLATION INSTRUCTIONS

On one end of each of your tie down inserts is a triangular plate referred to by Torklift as a bullet plate. In most cases, the tie down inserts should be installed with the shorter side of the bullet plate facing away from each other, i.e.. The shorter side of the front insert should point to the front of the truck and the shorter side of the rear insert should point towards the rear of the truck.



DRIVERS SIDE FRONT



DRIVERS SIDE REAR

Once installed, attach the TorkLift directional stickers to the face of the bullet plate on the insert as a reminder.

Torklift International Limited Lifetime Warranty Information

1901 Fryar Ave Sumner, WA 98390

Torklift will require proof of purchase to register, with pictures of any defective product before issuing a replacement. Torklift will not register any product without proof of purchase, which can be faxed, scanned, emailed, or mailed to the information provided below. Torklift warrants its hitches, custom hitch receivers, frame mounted tie downs, turnbuckles, and accessories (excluding wire harnesses which carry a 90 day warranty) from date of purchase against defects in material and workmanship under normal use and service for the ownership life of the original consumer purchaser. All plastic, rubber, and/ or electrical components maintain a warranty of up to one year from the date of the purchase. **ALL COMMERCIAL APPLICATIONS ARE WARRANTED FOR A PERIOD OF 90 DAYS FROM THE DATE OF INSTALLATION/SERVICE.** Torklift will replace **FREE OF CHARGE** any part which proves defective in material or workmanship when presented to Torklift, **TRANSPORTATION CHARGES PREPAID** by purchaser, at the address above. **THIS WARRANTY IS LIMITED TO DEFECTIVE PARTS REPLACEMENT ONLY. LABOR CHARGES AND/OR DAMAGE INCURRED IN INSTALLATION OR REPLACEMENT, AS WELL AS INCIDENTAL AND CONSEQUENTIAL DAMAGES CONNECTED THEREWITH ARE EXCLUDED.** This warranty does not include the finish or paint on our products. Rusting, cracking or peeling of the finish is also excluded. Some states do not allow the exclusion or limitation of incidental or consequential damages, so the above limitation or exclusion may not apply to you. Any damage to Torklift products as a result of misuse, abuse, neglect, accident, improper installation or any use violative of instructions furnished by Torklift or **WHEN USED IN ANY COMMERCIAL APPLICATION WILL VOID THE WARRANTY.** This warranty gives you specific legal rights, and you may also have rights which vary from state to state. With warranty service, you may be able to go to a small claims court, a state court or a federal district court.



INTERNATIONAL

**1901 Fryar Avenue Sumner WA, 98390
Phone (800) 246-8132 Fax (253) 854-8003**

Or visit our website: www.TorkLift.com

Dear Valued Customer,

Thank you for making TorkLift your choice for truck, camper packages and accessories for your vehicle. By choosing TorkLift products, you have chosen a company that has been serving the RV industry for nearly 40 years and whose name has become synonymous with strength, quality and advanced design and installation.

Please take a few moments of your time to complete the Product Registration Warranty Card on the next page. When registering your newly purchased TorkLift products, you can be assured that your contact information is secure and that you and your product are getting the attention and respect that you deserve.

Thank you again for choosing TorkLift quality products.

**Register for your lifetime warranty and receive a free
Torklift International gift.**

To Fax: Send copies of the questionnaire, warranty card and receipt to
253-854-8003

To E-mail: Send copies of the questionnaire, warranty card and receipt to
warranty@torklift.com



To Mail: Send to Torklift International 1901 Fryar Ave Sumner, Wa 98390

OFFICIAL WARRANTY REGISTRATION CARD

PLEASE FILL OUT THIS FORM COMPLETELY AND RETURN TO TORKLIFT WITHIN

30 DAYS OF PURCHASE ACCOMPANIED BY A COPY OF YOUR ORIGINAL RECEIPT

1. PART(S) PURCHASED

TODAY'S DATE: _____

PART #: _____ PART #: _____

PART #: _____ PART #: _____

PART #: _____ PART #: _____

2. PURCHASER INFORMATION

NAME: _____

ADDRESS: _____

CITY: _____ STATE: _____ ZIP / POSTAL CODE: _____

PHONE: (____) _____ - _____ EMAIL: _____

3. TRUCK INFORMATION

YEAR: _____ MAKE: _____

MODEL: _____ BED LENGTH: _____

4. CAMPER INFORMATION

YEAR: _____ MAKE: _____ MODEL: _____

5. DEALER INFORMATION

PURCHASED FROM: _____

ADDRESS: _____

CITY: _____ STATE: _____ ZIP / POSTAL: _____

INSTALLED BY: _____ OWNER ABOVE DEALER ANOTHER DEALER

IF ANOTHER DEALER, WHO: _____